

RG

The Collection



Roberto
GIOVANNINI
FIRENZE 1958

The Collection

INDEX_INDICE

DINING TABLES	pag 5	CONSOLE TABLES	pag 250
Tavoli		Consolle	
— CUSTOMISABLE TABLES	pag 6	BEDROOMS	pag 286
Tavoli personalizzabili		Camere	
— MODULAR TABLES	pag 12	— DOUBLE BEDS	pag 288
Tavoli componibili		Letti matrimoniali	
— ONE PIECE TABLES	pag 26	— SINGLE BEDS	pag 314
Tavoli completi		Letti singoli	
DINING CHAIRS AND STOOLS	pag 42	— CHESTS OF DRAWERS AND NIGHT TABLES	pag 322
Sedie e sgabelli		Cassettoni e comodini	
— DINING CHAIRS	pag 46	DESKS	pag 340
Sedie		Scrivanie	
— STOOLS	pag 62	BOOKCASES	pag 350
Sgabelli		Librerie	
LIVING AREA FURNITURE	pag 78	ACCESSORIES	pag 362
Mobili zona giorno		Accessori	
— SIDEBOARDS	pag 82	— ORNAMENTS	pag 366
Credenze		Ornamenti	
— DISPLAY CABINETS	pag 98	— FIREPLACE	pag 368
Vetrine		Camini	
— TELEVISION UNITS	pag 106	— PEDESTALS	pag 372
Porta TV		Piedistalli	
SOFAS AND ARMCHAIRS	pag 112	— WALL SHELVES	pag 377
Divani e poltrone		Mensole	
COFFEE AND SIDE TABLES	pag 156	— SCULPTURES	pag 383
Tavolini		Sculture	
— COFFE TABLES	pag 158	— BAS-RELIEF	pag 390
Tavolini da caffè		Bassorilievi	
— SIDE TABLES	pag 172	WOOD FINISHES	pag 396
Tavolini lato divano		Finiture legno	
MIRROR FRAMES	pag 188	MARBLES	pag 405
Specchiere		Marmi	





DINING TABLES TAVOLI DA PRANZO

- CUSTOMIZABLE TABLES pag 6
Tavoli personalizzabili
- MODULAR TABLES pag 12
Tavoli componibili
- ONE-PIECE TABLES pag 26
Tavoli completi



Available in any finish_ Disponibili in tutte le finiture

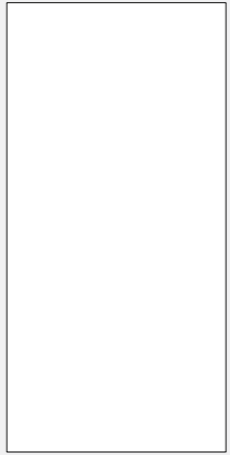

SMOOTH TOP/PIANO LISCIO

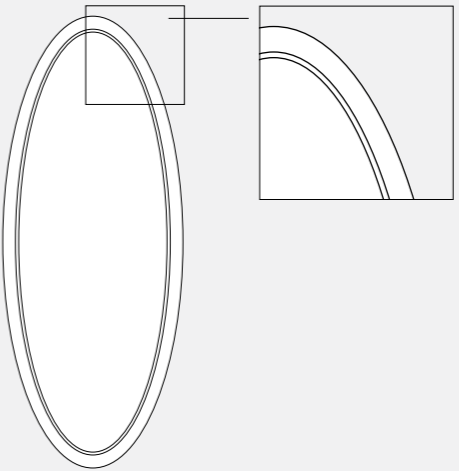

TOP WITH ENGRAVED TRACK* /PIANO CON BINARIO*

* Available for all top shapes
Disponibile per tutte le forme di piano

PARQUET TOPS_PIANI PARCHETTATI

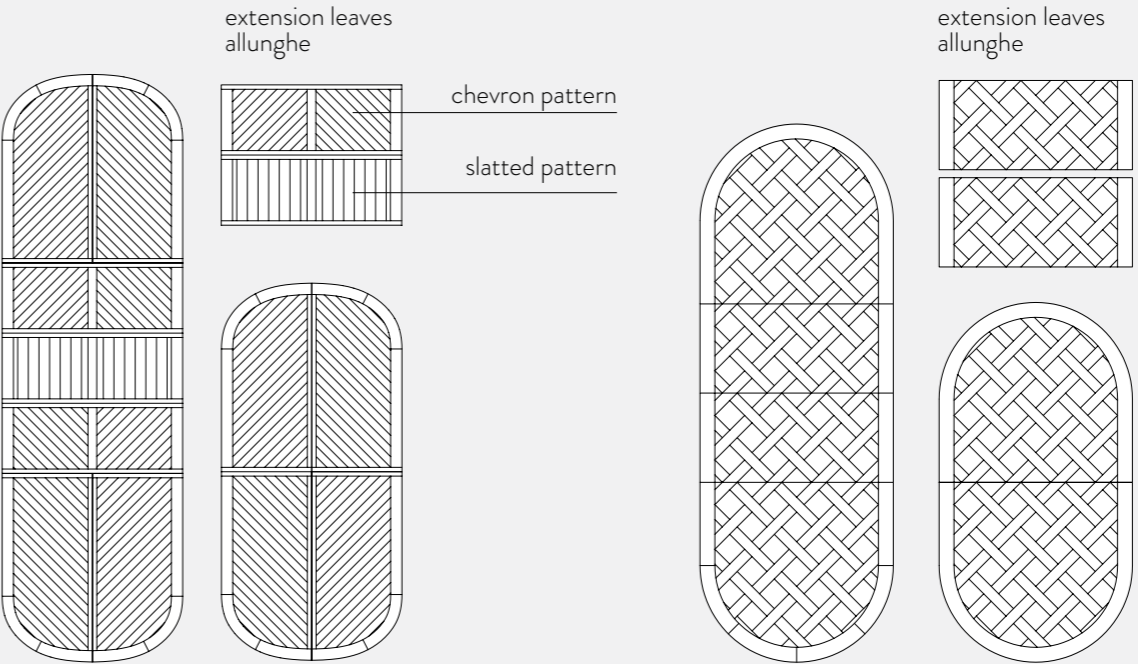

CHEVRON TOP/PIANO CHEVRON

VERSAILLES TOP/PIANO VERSAILLES

AVAILABLE IN THE FOLLOWING FINISHES_DISPONIBILI NELLE SEGUENTI FINITURE



GT096
Rovere Decapé



GT097
Colonial Decapé

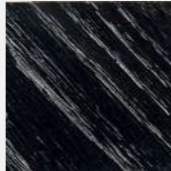

GT098
Nero Decapé

CUSTOMIZABLE DINING TABLES TAVOLI DA PRANZO PERSONALIZZABILI

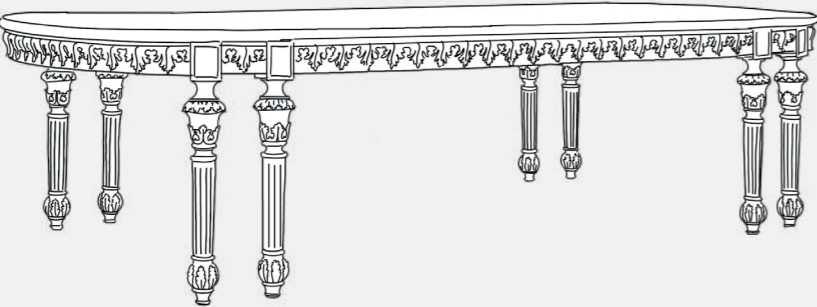

The customisable tables can be fixed or extendable, with separate, drop-in extensions, complete with carved band motif. Tables longer than 3 metres are supplied in sections.

The bases, legs and band motifs are available in all finish variants: **Standard, Elite, Luxury.**

Customisable tables are tables with multiple legs and/or stretchers, complete with carved bands of motifs, making adaptation possible to a number of size combinations. Paired with: **parquet oak tops in Versailles or Chevron design**, available in three finishes, or **smooth tops or with a double line** engraved around the perimeter (track), available in all finish variants: **Standard, Elite, Luxury.**

In the case of gold or silver leaf finish on top, the appearance is 'dappled' due to the type of material and processing.

I tavoli personalizzabili posso essere fissi o allungabili, con allunghe separate non a scomparsa, complete di fascia intagliata. I tavoli di lunghezza superiore a 3 metri sono forniti divisi in parti.

La base, le gambe e i decori sono disponibili nelle varianti: **Standard, Elite, Luxury.**

I tavoli personalizzabili sono tavoli con gambe multiple e o crociate, completi di fasce intagliate che permettono di adattarsi a numerose combinazioni di misure. Abbinati con: **piani in rovere parchettato a disegno Versailles o Chevron**, disponibili in tre finiture, o **piani lisci o con doppia linea** incisa lungo il perimetro (binario), disponibili in tutte le varianti di finitura: **Standard, Elite, Luxury.**

In caso di finitura in foglia oro o argento i piani si presentano con un aspetto "a toppe" dovuto alla tipologia di materiale ed alla lavorazione.



Majestic

End XVIII C. Louis XVI French

Art. 1424

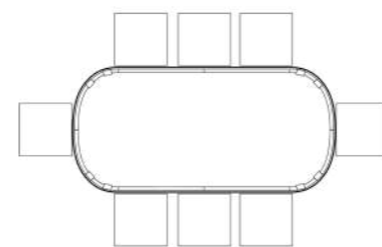

Art. 1424CQAC (CQFC)
(photo ref. / foto ref.)

Majestic dining table 12 legs
Chevron parquet top
end XVIII C. Louis XVI French
Tavolo da pranzo Majestic
12 gambe piano
parchettato Chevron
fine XVIII Sec. Luigi XVI Francese

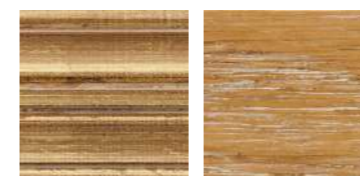

Base G079
Oro Leggero

Top GT096
Rovere Decapè

- * 8 legs table_tavolo a 8 gambe
- ** 4 legs element_elemento a 4 gambe
- *** slatted pattern_finitura a doghe

Customize on request_misure custom su richiesta

ARTICLE / ARTICOLO	DIMENSIONS / DIMENSIONI	EXTENDABLE / ALLUNGABILE	MATCHING TOPS / VARIANTI PIANO	
			SMOOTH/ENGRAVED TOP LISCIO/CON BINARIO	CHEVRON
WOOD / LEGNO				
1424CDF*	241 x 144 x h 79 cm		✓	
1424CDFC*	241 x 144 x h 79 cm			✓
1424CQF	301 x 144 x h 79 cm		✓	
1424CQFC	301 x 144 x h 79 cm			✓
1424CQA	301 x 144 x h 79 cm	✓	✓	
1424CQAC	301 x 144 x h 79 cm	✓		✓
EXTENSIONS LEAVES / ALLUNGHE				
1424ALL	57,5 x 144 x h 79 cm	single /singola	✓	
1424ALLC	115 x 144 x h 79 cm	pair / coppia		✓
1424ALLCT***	57,5 x 144 x h 79 cm	single /singola		✓
1424ALLCK**	230 x 144 x h 79 cm			✓
1424ALLK**	230 x 144 x h 79 cm		✓	

Ducale

End XVIII C. Neoclassical Piedmontese

Art. 1395

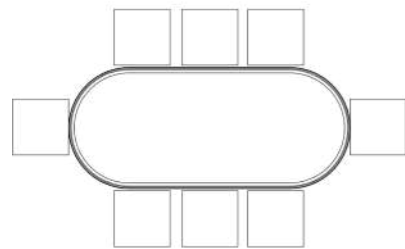

Art. 1395CQFP (CQAP)
(photo ref. / foto ref.)

Ducale dining table
end XVIII C. Neoclassical Piedmontese
Versailles top
Tavolo da pranzo Ducale
fine XVIII Sec. Neoclassico Piemontese
piano Versailles



Base G105 Argento Leggero
Top GT096 Rovere Decapè and Black / Nero

Customize on request_misure custom su richiesta

ARTICLE / ARTICOLO	DIMENSIONS / DIMENSIONI	EXTENDABLE / ALLUNGABILE	MATCHING TOPS / VARIANTI PIANO	
			WOOD / LEGNO	
			SMOOTH/ENGRAVED LISCIO/CON BINARIO	VERSAILLES
1395CDF	242 x 130 x h 79 cm		✓	
1395CDFP	242 x 130 x h 79 cm			✓
1395CQF	302 x 130 x h 79 cm		✓	
1395CQFP	302 x 130 x h 79 cm			✓
1395CDA	242 x 130 x h 79 cm	✓	✓	
1395CDAP	242 x 130 x h 79 cm	✓		✓
1395CQA	302 x 130 x h 79 cm	✓	✓	
1395CQAP	302 x 130 x h 79 cm	✓		✓
EXTENSION LEAVES / ALLUNGHE				
1395ALL	60 x 130 x h 14 cm	single /singola	✓	
1395ALLP	60 x 130 x h 14 cm	single /singola		✓

Florentia

End XVIII C. Tuscan

Art. 1434

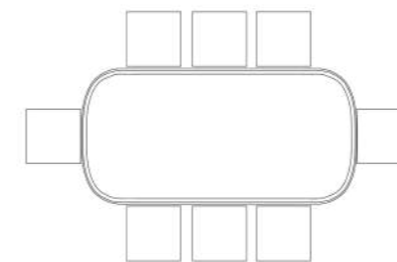

Art. 1434CPHAC (CPHFC)
(photo ref. / foto ref.)

Florentia dining table
end XVIII C. Tuscan
Chevron Top
Tavolo da pranzo Florentia
fine XVIII Sec. Toscano
Piano Chevron

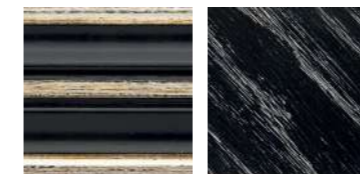

Base G098 Noir Argento
Top GT098 Nero Decapè

*** slatted pattern_finitura a doghe

Customize on request_misure custom su richiesta

ARTICLE / ARTICOLO	DIMENSIONS / DIMENSIONI	EXTENDABLE / ALLUNGABILE	MATCHING TOPS / VARIANTI PIANO	
			WOOD / LEGNO	
			SMOOTH/ENGRAVED LISCIO/CON BINARIO	CHEVRON
1434CSHF	180 x 150 x h 79 cm		✓	
1434CSHFC	180 x 150 x h 79 cm			✓
1434CDHF	240 x 150 x h 79 cm		✓	
1434CDHFC	240 x 150 x h 79 cm			✓
1434CPHF	300 x 150 x h 79 cm		✓	
1434CPHFC	300 x 150 x h 79 cm			✓
1434CSHA	180 x 150 x h 79 cm	✓	✓	
1434CSHAC	180 x 150 x h 79 cm	✓		✓
1434CDHA	240 x 150 x h 79 cm	✓	✓	
1434CDHAC	240 x 150 x h 79 cm	✓		✓
1434CPHA	300 x 150 x h 79 cm	✓	✓	
1434CPHAC	300 x 150 x h 79 cm	✓		✓
EXTENSIONS LEAVES / ALLUNGHE				
1434ALLT	55 x 150 x h 14 cm	single /singola	✓	
1434ALLC	110 x 150 x h 14 cm	pair / coppia		✓
1434ALLCT***	55 x 150 x h 14 cm	single /singola		✓

MODULAR TABLES MODULAR TAVOLI DA PRANZO COMPONENTI

The modular tables are composed of a base, single or double, to which a top of various sizes and shapes, in two thicknesses, can be attached: one for extendable tops (group A) and one for fixed tops (group B). The extension leaves are always separate, not fold-away. The construction of these types of tables enables the realisation of very large dimensions by using several bases. The bases are available in all finish variants: **Standard, Elite, Luxury**. The recommended shape/base combinations are indicated in each item's specification table. Modular table bases can also be combined with glass tops.

I tavoli componibili sono composti da un basamento, singolo o doppio, al quale abbinare un piano di varie dimensioni e forme, di due spessori: uno per piani allungabili (gruppo A) e uno per piani fissi (gruppo B). Le allunghe sono sempre separate, non a scomparsa. La costruzione di queste tipologie di tavoli, permette di realizzare misure molto grandi utilizzando più basi. I piani in abbinamento possono essere: **Standard, Elite, Luxury**. Gli abbinamenti consigliati forma/base sono indicati in ciascuna tabella. Le basi dei tavoli componibili sono abbinabili anche a piani in vetro.

MODULAR TABLES (base + table top) TAVOLI COMPONENTI (base + piano tavolo)

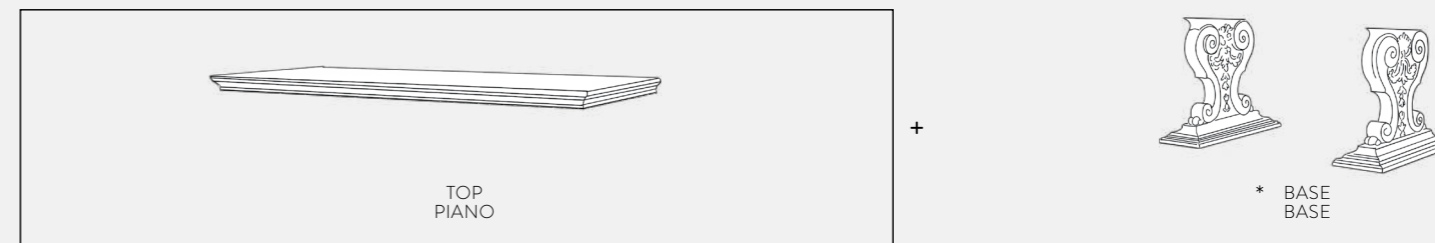

* If purchased in pairs, single bases can also be completed with rectangular and ribbed tops.
Se acquistate in coppia, le basi singole possono essere completate anche con piani rettangolari e centinati.

SHAPE FOR WOODEN AND GLASS TOP_FORME PER PIANI DI LEGNO E DI VETRO



TABLE TOP TYPES_TIPOLOGIA PIANO

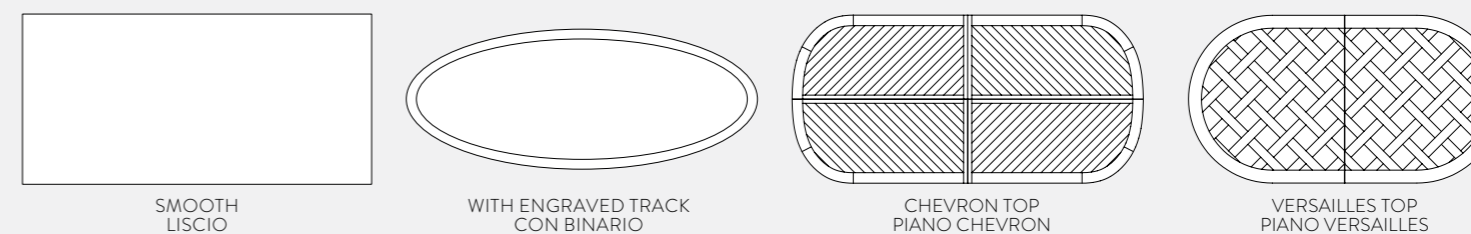

TYPE A_EDGINGS FOR EXTENDABLE AND FIX TABLE TOPS_TIPOLOGIA A_PROFILI TAVOLI PER PIANI ALLUNGABILI E FISSI*

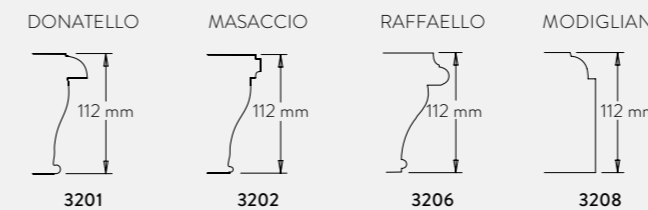

TYPE B_EDGINGS FOR FIX TABLE TOPS ONLY_TIPOLOGIA B_PROFILI TAVOLI SOLO FISSI

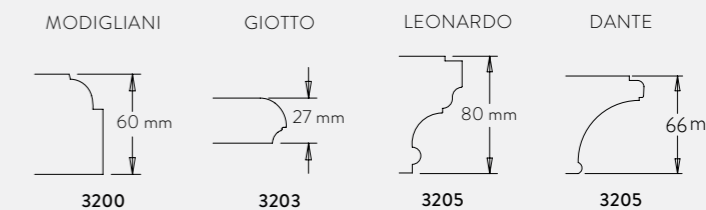

(* EXTENSION LEAVES INCLUDED_PIANI COMPENSIVI DI ALLUNGHE)



Lira

Beg. XVIII C. Neoclassical Italian

Art. 204



Art. 204
(photo ref. / foto ref.)

Pair of dining bases Lira
beg. XVIII C. Neoclassical Italian
Coppia di basi per tavolo pranzo a Lira
inizio XVIII Sec. Neoclassico Italiano



Decoro
G012 Greige

TABLE BASE / BASE TAVOLO			
204			
DIMENSIONS / DIMENSIONI			
73 x 28 x h 74 cm			
Details about tops on page 14_dettagli sui piani a pagina 14			
SHAPES FOR TOPS / FORME PER PIANI			
ROUNDED EDGES / CENTINATO	RECTANGULAR / RETTANGOLARE	SEMI-OVAL / SEMI-OVALE	ROUND / TONDO
✓	✓	-	-
TABLE TOP TYPES / TIPOLOGIA PIANI			
WOODEN TOP / PIANO LEGNO			GLASS TOP/ PIANO VETRO
SMOOTH / LISCIO	TRACK / CON BINARIO	PARQUET / PARCHETTATO	
EDGINGS / PROFILI			
TYPE A / TIPOLOGIA A			

Chirlanda

End XVIII C. Neoclassical French

Art. 1334



Art. 1334
(photo ref. / foto ref.)

Pair of dining bases end XVIII C.
Neoclassical French
Coppia di basi per tavolo pranzo fine
XVIII Sec. Neoclassico Francese



Decoro
G022 Argento Pitti

TABLE BASE / BASE TAVOLO			
1334			
DIMENSIONS / DIMENSIONI			
64 x 26 x h 74 cm			
Details about tops on page 14_dettagli sui piani a pagina 14			
SHAPES FOR TOPS / FORME PER PIANI			
ROUNDED EDGES / CENTINATO	RECTANGULAR / RETTANGOLARE	SEMI-OVAL / SEMI-OVALE	ROUND / TONDO
✓	✓	-	-
TABLE TOP TYPES / TIPOLOGIE PIANI			
WOODEN TOP / PIANO LEGNO			GLASS TOP / PIANO VETRO
SMOOTH / LISCIO	TRACK / CON BINARIO	PARQUET / PARCHETTATO	
EDGINGS / PROFILI			
TYPE A / TIPOLOGIA A			

Prestige Pair

2nd half XVII C. Baroque Romano

Art. 828



Art. 828
(photo ref. / foto ref.)

Pair of dining bases with garland
2nd half XVII C. Baroque Romano
Coppia di basi
per tavolo pranzo con ghirlanda
2° metà XVII Sec. Barocco Romano

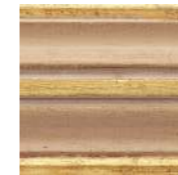

Decoro
G032 Pickled Pine e Oro

TABLE BASE / BASE TAVOLO			
828			
DIMENSIONS / DIMENSIONI			
79 x 34 x h 73 cm			
Details about tops on page 14_dettagli sui piani a pagina 14			
SHAPES FOR TOP / FORME PER PIANI			
ROUNDED EDGES / CENTINATO	RECTANGULAR / RETTANGOLARE	SEMI-OVAL / SEMI-OVALE	ROUND / TONDO
✓	✓	-	-
TABLE TOP TYPES / TIPOLOGIE PIANI			
WOODEN TOP / PIANO LEGNO			GLASS TOP / PIANO VETRO
SMOOTH / LISCIO	TRACK / CON BINARIO	PARQUET / PARCHETTATO	
EDGINGS / PROFILI			
TYPE A / TIPOLOGIA A			

Prestige Single

2nd half XVII C. Baroque Roman

Art. 1012



Art. 1012
(photo ref. / foto ref.)

Dining table base
2nd half XVII C. Baroque Roman
Base tavolo pranzo
2° metà XVII Barocco Romano



Decoro
G012 Greige

TABLE BASE / BASE TAVOLO			
1012			
DIMENSIONS / DIMENSIONI			
Ø 82 x h 73 cm			
Details about tops on page 14_dettagli sui piani a pagina 14			
SHAPES FOR TOPS / FORME PER PIANI			
ROUNDED EDGES / CENTINATO	RECTANGULAR / RETTANGOLARE	SEMI-OVAL / SEMI-OVALE	ROUND / TONDO
-	-	✓	✓
TABLE TOP FINISHING / TIPOLOGIE PIANO			
WOODEN TOP / PIANO LEGNO			GLASS TOP / PIANO VETRO
SMOOTH / LISCIO	TRACK / CON BINARIO	PARQUET / PARCHETTATO	
EDGINGS FOR WOODEN TOPS / PROFILI TAVOLO LEGNO			
TYPE A / TIPOLOGIA A		TYPE B / TIPOLOGIA B	

Acanthus

End XVI C. Renaissance Italian

Art. 1145



Art. 1145
(photo ref. / foto ref.)

Dining table base
end XVI C. Renaissance Italian
Base tavolo pranzo
fine XVI Sec. Rinascimento Italiano



Decoro
G032 Pickled Pine e Oro

TABLE BASE / BASE TAVOLO			
1145			
DIMENSIONS / DIMENSIONI			
Ø 66 x 66 x h 75 cm			
Details about tops on page 14_dettagli sui piani a pagina 14			
SHAPES FOR TOPS / FORME PER PIANI			
ROUNDED EDGES / CENTINATO	RECTANGULAR / RETTANGOLARE	SEMI-OVAL / SEMI-OVALE	ROUND / TONDO
-	-	✓	✓
TABLE TOP TYPES / TIPOLOGIE PIANI			
WOODEN TOP / PIANO LEGNO			GLASS TOP / PIANO VETRO
SMOOTH / LISCIO	TRACK / CON BINARIO	PARQUET / PARCHETTATO	
EDGINGS / PROFILI			
TYPE A / TIPOLOGIA A			

Neo-classico

Neoclassical Tuscan

Art. 1350

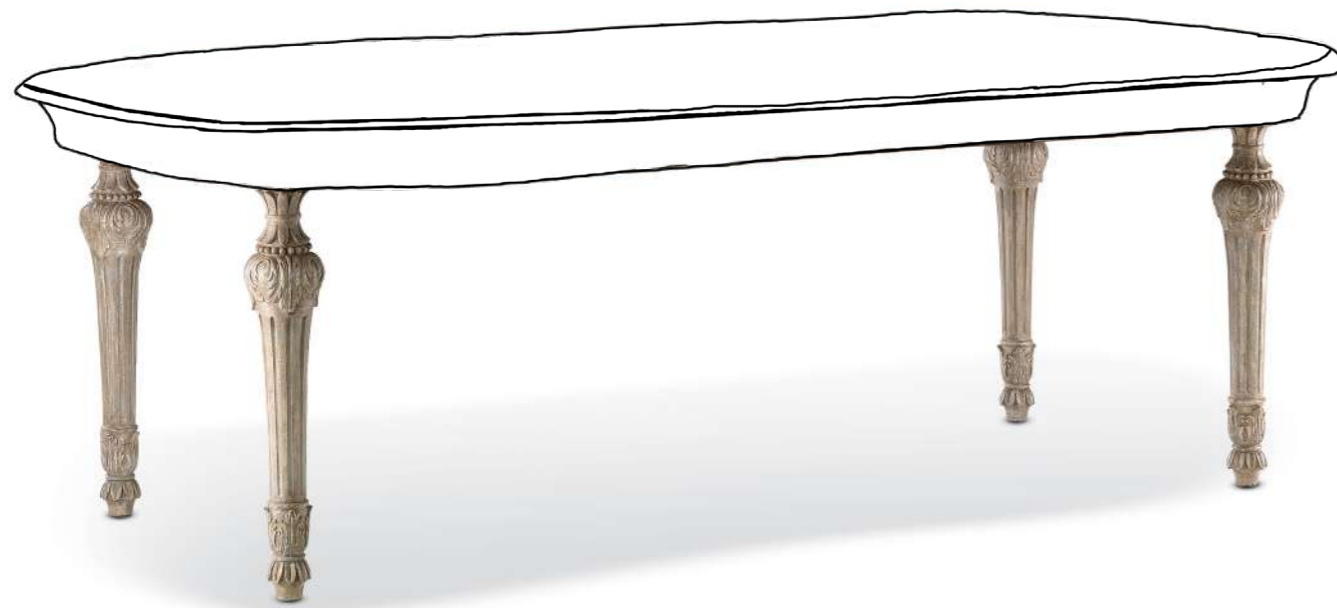

Art. 1350
(photo ref. / foto ref.)

Dining table legs
Neoclassical Tuscan
Gambe per tavolo da pranzo
Neoclassico Toscano



Decoro
G012 Greige

TABLE BASE / BASE TAVOLO	
1350	
DIMENSIONS / DIMENSIONI	
h 68 cm	

Details about tops on page 14_dettagli sui piani a pagina 14

SHAPES FOR TOPS / FORME PER PIANI			
ROUNDED EDGES / CENTINATO	RECTANGULAR / RETTANGOLARE	SEMI-OVAL / SEMI-OVALE	ROUND / TONDO
✓	✓	✓	✓
TABLE TOP TYPES / TIPOLOGIE PIANI			
SMOOTH / LISCIO	TRACK / CON BINARIO	PARQUET / PARCHETTATO	
EDGINGS / PROFILI			
TYPE A / TIPO A			

Tuscania

XVII C. Tuscan

Art. 1419



Art. 1419
(photo ref. / foto ref.)

Dining table base
XVII C. Tuscan
Base per tavolo pranzo
XVII Sec. Toscano



Decoro
A030 Castagna e Oro

TABLE BASE / BASE TAVOLO	
1419	
DIMENSIONS / DIMENSIONI	
143 x 86 x h 73 cm	

Details about tops on page 14_dettagli sui piani a pagina 14

SHAPES FOR TOPS / FORME PER PIANI			
ROUNDED EDGES / CENTINATO	RECTANGULAR / RETTANGOLARE	SEMI-OVAL / SEMI-OVALE	ROUND / TONDO
✓	✓	-	-
TABLE TOP TYPES / TIPOLOGIE PIANI			
WOODEN TOP / PIANO LEGNO			GLASS TOP / PIANO VETRO
SMOOTH / LISCIO	TRACK / CON BINARIO	PARQUET / PARCHETTATO	
EDGINGS / PROFILI			
TYPE A / TIPO A		TYPE B / TIPO B	

Cigni

Beg. XIX C. Empire French

Art. 598



Art. 598
(photo ref. / foto ref.)

Swans dining table base
beg. XIX C. Empire French
Base tavolo con cigni
inizio XIX sec. Impero Francese



Decoro
G095 Antico Veneziano

TABLE BASE / BASE TAVOLO			
598			
DIMENSIONS / DIMENSIONI			
79 x 34 x h 73 cm			
Details about tops on page 14_dettagli sui piani a pagina 14			
SHAPES FOR TOPS / FORME PER PIANI			
ROUNDED EDGES / CENTINATO	RECTANGULAR / RETTANGOLARE	SEMI-OVAL / SEMI-OVALE	ROUND / TONDO
-	-	✓	✓
TABLE TOP TYPES / TIPOLOGIE PIANI			
WOODEN TOP / PIANO LEGNO			GLASS TOP / PIANO VETRO
SMOOTH / LISCIO	TRACK / CON BINARIO	PARQUET / PARCHETTATO	
EDGINGS / PROFILI			
TYPE A / TIPO A		TYPE B / TIPO B	



Bistrot

Baroque Florentine

Art. 1385B



Art. 1385B

(photo ref. / foto ref.)

Dining table base Bistrot with leaves Baroque Florentine
Base tavolo Bistrot con foglie Barocco Fiorentino



Decoro
G079 Oro Leggero

TABLE BASE / BASE TAVOLO			
1385B			
DIMENSIONS / DIMENSIONI			
Ø 81 x h 70,5 cm			
Details about tops on page 14_dettagli sui piani a pagina 14			
SHAPES FOR TOPS / FORME PER PIANI			
ROUNDED EDGES / CENTINATO	RECTANGULAR / RETTANGOLARE	SEMI-OVAL / SEMI-OVALE	ROUND / TONDO
-	-	-	✓
TABLE TOP TYPE/ TIPOLOGIE PIANI			
SMOOTH / LISCIO	TRACK / CON BINARIO	PARQUET / PARCHETTATO	
EDGINGS / PROFILI			
TYPE A / TIPO A		TYPE B / TIPO B	

Luigi XIV

Half XVII C. Louis XIV Tuscan

Art. 1231B



Art. 1231B

(photo ref. / foto ref.)

Dining table base with cross-bar
half XVII C. Louis XIV Tuscan
Tavolo da pranzo base
con crociata alta
metà XVII Sec. Luigi XIV Toscano



Decoro
G043 Ebony

TABLE BASE / BASE TAVOLO			
1231B			
DIMENSIONS / DIMENSIONI			
133 x 63 x h 68 cm			
Details about tops on page 14_dettagli sui piani a pagina 14			
SHAPES FOR TOPS / FORME PER PIANI			
ROUNDED EDGES / CENTINATO	RECTANGULAR / RETTANGOLARE	SEMI-OVAL / SEMI-OVALE	ROUND / TONDO
✓	✓	-	-
TABLE TOP TYPE/ TIPOLOGIE PIANI			
SMOOTH / LISCIO	TRACK / CON BINARIO	PARQUET / PARCHETTATO	
EDGINGS / PROFILI			
TYPE A / TIPO A		TYPE B / TIPO B	

ONE-PIECE TABLES TAVOLI COMPLETI

The one-piece tables are finished models in terms of shape and dimensions, made in accordance with the harmony and proportions of the original antique tables' designs and are not modifiable; they are available in all finish variants: **Standard, Elite, Luxury**. The tops, either smooth or with the track perimeter engraving, decorated in gold or silver leaf have a 'dappled' appearance due to the type of material and processing.

Options available (not for all models):

- Top in glass or marble
- Insets in coloured glass or marble
- Versailles parquet finish (only parquet finishes)
- Insets in leather

I tavoli completi sono modelli definitivi per forma e misure, realizzati nel rispetto dell'armonia e proporzioni degli antichi originali e non sono modificabili; sono disponibili in tutte le varianti di finiture:

Standard, Elite, Luxury.

I piani, lisci o con binario, decorati in foglia oro o argento si presentano con un effetto "a toppe" dovuto alla tipologia del materiale e di lavorazione.

Opzioni disponibili (non su tutti i modelli):

- Piano vetro o marmo
- Incasso in vetro colorato o marmo
- Lavorazione parchettata Versailles (solo finiture parchettati)
- Incasso in cuoio

ONE-PIECE TABLES_TAVOLI COMPLETI

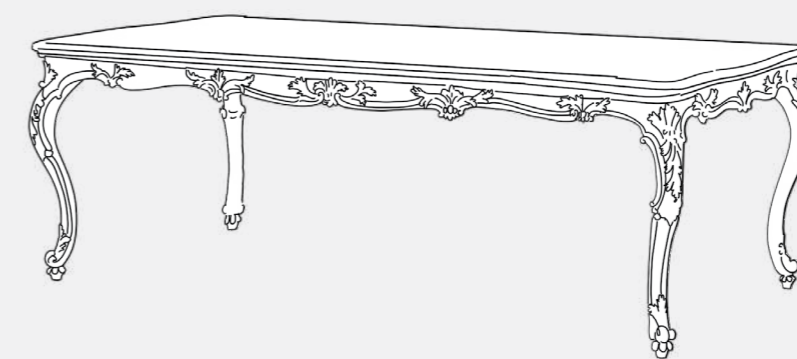

Canova
Half XVIII C. Venetian
Art. 1341KPP



Canova
Half XVIII C. Venetian
Art. 1341



Art. 1341
(photo ref. / foto ref.)

Dining table
half XVIII C. Venetian
Tavolo da pranzo
metà XVIII Sec. Veneziano

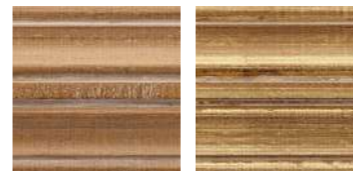

Top G067 Base G079
Rovere Sbiancato Oro Leggero

ARTICLE ARTICOLO	DIMENSIONS / DIMENSIONI
1341	225 x 115 x h 77 cm
1341PP	225 x 115 x h 77 cm
1341K	297 x 127 x h 77 cm
1341KPP	297 x 127 x h 77 cm

TABLE TOP OPTIONS / VARIANTI PIANO							
WOOD / LEGNO			GLASS TOP / VETRO CHIARO	COLORED GLASS / VETRO RETROVERNICIATO	MARBLE / MARMO		
SMOOTH/TRACK LISCIO/CON BINARIO	CHEVRON	VERSAILLES			STANDARD	ELITE A	ELITE B
1341	-	1341PP	-	-	-	-	-
1341K	-	1341KPP	-	-	-	-	-

Luigi XVI

End XVIII C. Neoclassical Italian

Art. 1058

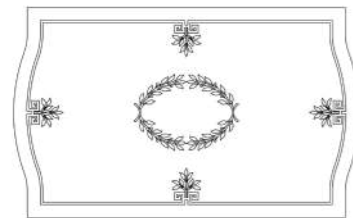

Engraved wooden top_incisione piano legno

Art. 1058

(photo ref. / foto ref.)

Dining table with carved leaves
end XVIII C. Neoclassical Italian
Tavolo da pranzo con fascia a foglie
fine XVIII Sec. Neoclassico Italiano



Decoro
G043 Ebony

DIMENSIONS / DIMENSIONI

171 x 104 x h 78 cm

Luigi XIV

Half XVII C. Louis XIV Tuscan

Art. 1231



Art. 1231

(photo ref. / foto ref.)

Dining table with cross-bar
half XVII C. Louis XIV Tuscan
Tavolo da pranzo con crociata alta
metà XVII Sec. Luigi XIV Toscano



Decoro
G043 Ebony

ARTICLE
ARTICOLO

1231

1231G

DIMENSIONS / DIMENSIONI

200 x 110 x h 76 cm

240 x 110 x h 76 cm

Rococò

Half XVIII C. Louis XV French

Art. 1448



Art. 1448
(photo ref. / foto ref.)

Round dining table
half XVIII C. Louis XV French
Tavolo tondo
metà XVIII sec. Luigi XV Francese



Decoro
G095 Antico Veneziano

DIMENSIONS / DIMENSIONI

Ø 140 x h 75 cm

TABLE TOP OPTIONS / VARIANTI PIANO

WOOD / LEGNO			GLASS TOP / VETRO CHIARO	COLORED GLASS / VETRO RETROVERNICIATO	MARBLE / MARMO		
SMOOTH/TRACK LISCIO/CON BINARIO	CHEVRON	VERSAILLES			STANDARD	ELITE A	ELITE B
✓	-	-	✓	✓	✓	✓	



Uffizi

End XVIII C. Tuscan

Art. 1443



Art. 1443
(photo ref. / foto ref.)

Hexagonal dining table with classic Grecian Fretwork top with metal details and leather embedding end XVIII C. Tuscan
Tavolo esagonale da pranzo con intaglio a greca, piano con profili in metallo e incasso in cuoio fine XVIII Sec. Toscano



Decoro
G079 Oro Leggero

ARTICLE ARTICOLO	DIMENSIONS / DIMENSIONI
1443	Ø 167 x h 78 cm
1443VP	Ø 167 x h 78 cm
1443VM	Ø 167 x h 78 cm

ARTICLE ARTICOLO	DIMENSIONS / DIMENSIONI	 *Octagonal_Ottagonale
1443G*	Ø 215 x h 78 cm	
1443GVP*	Ø 215 x h 78 cm	
1443GVM*	Ø 215 x h 78 cm	

TABLE TOP OPTIONS / VARIANTI PIANO						
WOOD / LEGNO			LEATHER INSET / INCASSO CUIOIO	MARBLE INSET / INCASSO MARMO		
SMOOTH/TRACK LISCIO/CON BINARIO	CHEVRON	VERSAILLES		STANDARD	ELITE A	ELITE B
1443	-	-	1443VP	1443VM	1443VM	1443VM
144G	-	-	1443GVP	1443GVM	1443GVM	1443GVM



Dining tables - Tavoli da pranzo

Bistrot

Baroque Florentine

Art. 1385



Art. 1385FC

(photo ref. / foto ref.)

Bistrot table with carved leaves and wooden top with glass inset
Baroque Florentine
Tavolo bistrot con foglie piano in legno e cristallo
Barocco fiorentino



Decoro
G079 Oro Leggero

ARTICLE ARTICOLO	DIMENSIONS / DIMENSIONI
1385FC	Ø 120 x h 76 cm
1385FL	Ø 120 x h 76 cm

TABLE TOP OPTIONS / VARIANTI PIANO						
WOOD / LEGNO				MARBLE / MARMO		
SMOOTH/TRACK LISCIO/CON BINARIO	CHEVRON	VERSAILLES	COLORED GLASS INSET / INSERTO VETRO RETROVERNICIATO	STANDARD	ELITE A	ELITE B
1385FL	-	-	1385FC	1385FC	1385FC	1385FC

Luigi Filippo

Half XIX C. Louis Philip French

Art. 1074



Art. 1074

(photo ref. / foto ref.)

Dining table with garland
half XIX C. Louis Philip French
Tavolo da pranzo con ghirlanda
metà XIX sec. Luigi Filippo Francese



Decoro
A014 A.C.O

DIMENSIONS / DIMENSIONI
Ø 120 x h 77 cm

Granduca

XVIII C. Italian

Art. 1081



Art. 1081
(photo ref. / foto ref.)

Round dining table
with crystal top and cross-bar
XVIII C. Italian
Tavolo pranzo tondo
con piano vetro e crociata
XVIII Sec. Italiano



Decoro
G042 Ebony e Oro

DIMENSIONS / DIMENSIONI

Ø 125 x h 75 cm

TABLE TOP OPTIONS / VARIANTI PIANO

WOOD / LEGNO			GLASS TOP INSET / INSERTO VETRO CHIARO	COLORED GLASS INSET / INSERTO VETRO RETROVERNICIATO	MARBLE / MARMO		
SMOOTH/TRACK LISCIO/CON BINARIO	CHEVRON	VERSAILLES			STANDARD	ELITE A	ELITE B
✓	-	-	✓	✓	✓	✓	

Granduca Wood

XVIII C. Italian

Art. 1081PL



Art. 1081PL
(photo ref. / foto ref.)

Round dining table
with cross-bar and wooden top
XVIII C. Italian
Tavolo pranzo tondo con crociata
e piano in legno
XVIII Sec. Italiano



Decoro
G043 Ebony

DIMENSIONS / DIMENSIONI

Ø 150 x 75 cm

Crab

Beg. XIX C. Charles X French

Art. 1185

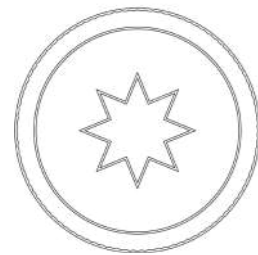

Engraved wooden top_incisione piano legno

Art. 1185

(photo ref. / foto ref.)

Crab round dining table
Gala profile with marble top
beg. XIX C. Charles X French
Tavolo da pranzo tondo a granchio
piano profilo Gala con marmo
inizio XIX Sec. Carlo X Francese

ARTICLE ARTICOLO	DIMENSIONS / DIMENSIONI
1185	Ø 110 x h 75 cm
1185D90	Ø 90 x h 75 cm
1185D80	Ø 80 x h 75 cm



Decoro
G086 Noir

TABLE TOP OPTIONS / VARIANTI PIANO							
WOOD / LEGNO			GLASS TOP / VETRO CHIARO	COLORED GLASS / VETRO RETROVERNICIATO	MARBLE / MARMO		
SMOOTH/TRACK LISCIO/CON BINARIO	CHEVRON	VERSAILLES			STANDARD	ELITE A	ELITE B
1185	-	-	-	-	1185	1185	1185
1185D90	-	-	-	-	1185D90	1185D90	1185D90
1185D80	-	-	-	-	1185D80	1185D80	1185D80

Majestic Welcome

End XVIII C. Louis XVI French

Art. 1306



Art. 1306

(photo ref. / foto ref.)

Welcome table marble top
end XVIII C. Louis XVI French
Tavolo da ingresso piano in marmo
fine XVIII Sec. Luigi XVI Francese



Decoro
G006 Provence

DIMENSIONS / DIMENSIONI	
Ø 142 x h 75 cm	

TABLE TOP OPTIONS / VARIANTI PIANO							
WOOD / LEGNO					MARBLE / MARMO		
SMOOTH/TRACK LISCIO/CON BINARIO	CHEVRON	VERSAILLES	GLASS TOP INSET/ INSERTO VETRO CHIARO	INSET COLORED GLASS / INSERTO VETRO RETROVERNICIATO	STANDARD	ELITE A	ELITE B
✓	-	-	-	✓	✓	✓	✓



DINING CHAIRS AND STOOLS SEDIE E SGABELLI

— DINING CHAIRS
Sedie

pag 44

— STOOLS
Sgabelli

pag 62



DINING CHAIRS AND STOOLS

SEDIE E SGABELLI

The dining chairs and armchairs and the stools and benches are made of carved solid wood and are available in all finish variants: **Standard, Elite, Luxury**. All items in the catalogue can be supplied with upholstery chosen from the Roberto Giovannini "Mosaico" and "Rondò" fabric selections or in neutral-coloured muslin or in the customer's fabric (C.O.M.). The letters PE indicate craftsmanship in leather selected from the Roberto Giovannini collection or supplied by the customer (C.O.M.). For some articles it is possible to choose a fixed or removable seat cushion (versions in fabric). The options for the padding finishes can be:

- Single edge-piping in fabric
- Matching trimmings (RG or supplied by the customer)
- Metal studs (gold, black, chrome, antique effect), the standard variant for leather coverings (PE).

Certified fire retardant padding is available on request.

Le sedie e poltroncine da pranzo e gli sgabelli e panchetti sono realizzati in legno massello intagliato e sono disponibili in tutte le varianti di finitura: **Standard, Elite, Luxury**. Tutti gli articoli a catalogo sono fornibili con rivestimento a scelta tra i tessuti selezione Roberto Giovannini "Mosaico" e "Rondò" oppure in mussolina di colore neutro o tessuto cliente (C.O.M.). Le lettere PE indicano la lavorazione in pelle, selezionata dalla collezione Roberto Giovannini, o fornita dal cliente (C.O.M.). Su alcuni modelli è disponibile la scelta tra seduta fissa e seduta con cuscino mobile (versioni in tessuto). Le rifiniture delle imbottiture possono essere, a scelta:

- Bordino singolo in tessuto
- Passamaneria a tono (RG o fornita dal cliente)
- Borchie in metallo (oro, nero, cromato, anticato), variante standard per lavorazione pelle PE. Su richiesta è possibile avere imbottiture ignifughe certificate.

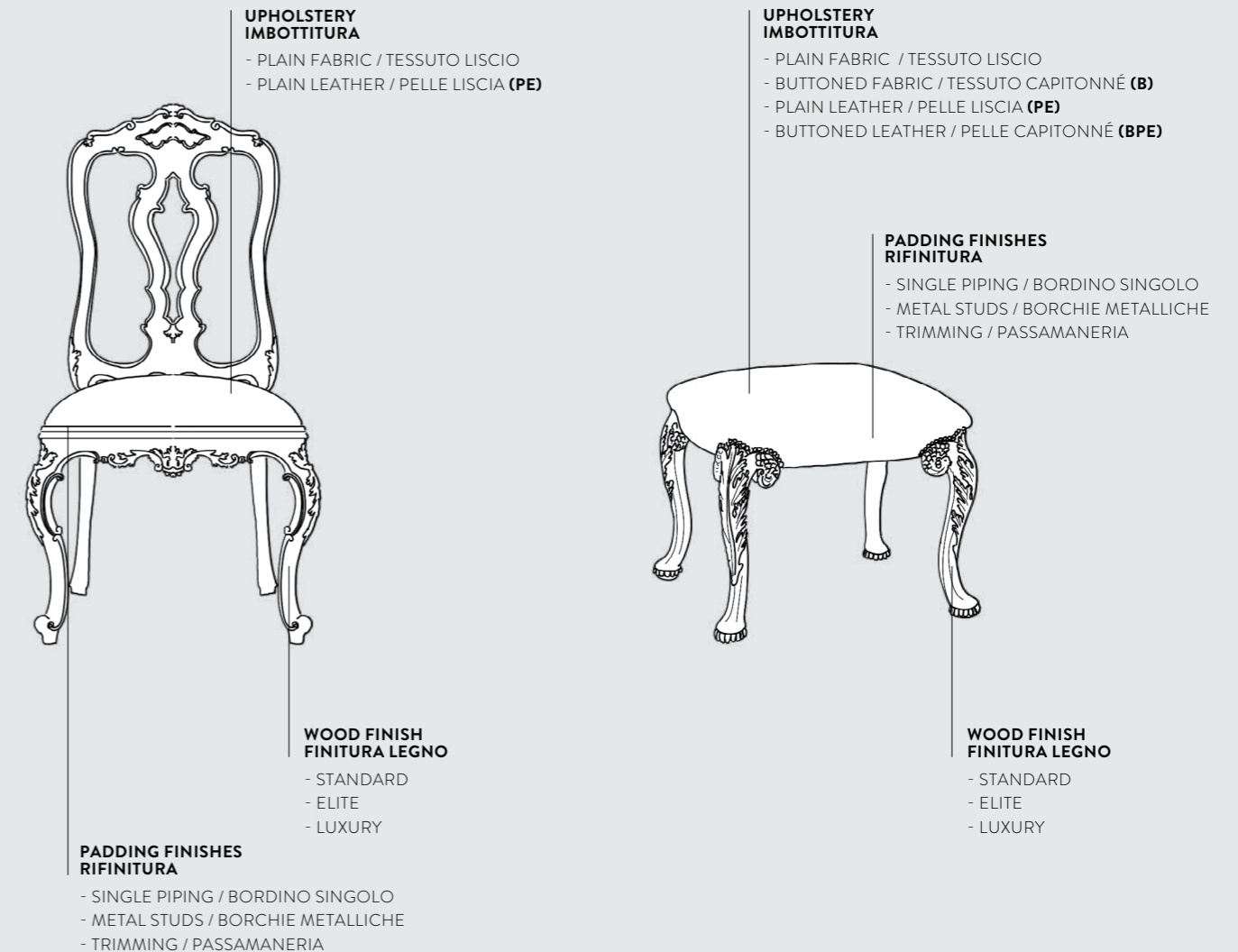



1399

Half XVIII C. Venetian

Art. 1399

(photo ref. / rif. foto)

Carver with upholstered backrest
half XVIII C. Venetian
Poltrona con schienale imbottito
metà XVIII sec. Veneziano

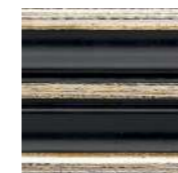

Decoro
G098 Noir e Argento

1400

Half XVIII C. Venetian

Art. 1400

(photo ref. / rif. foto)

Chair with upholstered backrest
half XVIII C. Venetian
Sedia con schienale imbottito
metà XVIII sec. Veneziano



Decoro
G079 Oro Leggero



DIMENSIONS / DIMENSIONI	
72 x 60 x h 110 cm	
UPHOLSTERY / IMBOTTITURA	
FABRIC / TESSUTO	PE (LEATHER / PELLE)
✓	✓



DIMENSIONS / DIMENSIONI	
62 x 53 x h 104 cm	
UPHOLSTERY / IMBOTTITURA	
FABRIC / TESSUTO	PE (LEATHER / PELLE)
✓	✓

951S

Half XVIII C. French



Art. 951S
(photo ref. / rif. foto)

Carver
half XVIII C. French
Poltroncina
metà XVIII C. Francese



Decoro
G009 Blanc

DIMENSIONS / DIMENSIONI	
69 x 69 x h 100 cm	
CHAIR WITH SEAT CUSHION / SEDIA CON CUSCINO DI SEDUTA	
951S	
UPHOLSTERY / IMBOTTITURA	
FABRIC / TESSUTO	PE (LEATHER / PELLE)
✓	✓

959

Beg. XVIII C. French



Art. 959
(photo ref. / rif. foto)

Chair
beg. XVIII C. French
Sedia
inizio XVIII C. Francese



Decoro
G009 Blanc

DIMENSIONS / DIMENSIONI	
55 x 55 x h 102 cm	
CHAIR WITH SEAT CUSHION / SEDIA CON CUSCINO DI SEDUTA	
959C	
UPHOLSTERY / IMBOTTITURA	
FABRIC / TESSUTO	PE (LEATHER / PELLE)
✓	✓

454G

Half XVIII C. Louis XVI



Art. 454G
(photo ref. / rif. foto)

Oval back carver
end XVIII C. Louis XVI
dining height
Poltrona schienale ovale
fine XVIII Sec. Luigi XVI
altezza pranzo



Decoro
G009 Blanc

DIMENSIONS / DIMENSIONI	
69 x 75 x h 106 cm	
UPHOLSTERY / IMBOTTITURA	
FABRIC / TESSUTO	PE (LEATHER / PELLE)
✓	✓

1347

End XVIII C. Louis XVI



Art. 1347
(photo ref. / rif. foto)

Oval back chair
end XVIII C. Louis XVI
Sedia con schienale ovale
fine XVIII sec. Luigi XVI



Decoro
G009 Blanc

DIMENSIONS / DIMENSIONI	
56 x 61 x h 106 cm	
UPHOLSTERY / IMBOTTITURA	
FABRIC / TESSUTO	PE (LEATHER / PELLE)
✓	✓

1045

XVIII C. Genoese



Art. 1045
(photo ref. / rif. foto)

Carver with shell
XVIII C. Genoese
Poltrona decoro conchiglia
XVIII sec. Genovese



Decoro
G079 Oro Leggero

DIMENSIONS / DIMENSIONI	
68 x 64 x h 104 cm	
UPHOLSTERY / IMBOTTITURA	
FABRIC / TESSUTO	PE (LEATHER / PELLE)
✓	✓

1044

XVIII C. Genoese



Art. 1044
(photo ref. / rif. foto)

Chair with shell
XVIII C. Genoese
Sedia decoro conchiglia
XVIII sec. Genovese



Decoro
G079 Oro Leggero

DIMENSIONS / DIMENSIONI	
55 x 64 x h 104 cm	
UPHOLSTERY / IMBOTTITURA	
FABRIC / TESSUTO	PE (LEATHER / PELLE)
✓	✓



540

End XVIII C. Neoclassical French



Art. 540
(photo ref. / rif. foto)

Carver fret carving
end XVIII C. Neoclassical French
Poltroncina decoro greca
fine XVIII sec. Neoclassico Francese



Decoro
G038 Oro Pitti

DIMENSIONS / DIMENSIONI			
64 x 65 x h 98 cm			
UPHOLSTERY / IMBOTTITURA			
FABRIC / TESSUTO		PE (LEATHER / PELLE)	
PLAIN / LISCIO	B (BUTTONED / CAPITONNÉ)	PLAIN / LISCIO	BPE (BUTTONED / CAPITONNÉ)
✓	-	✓	-

541

End XVIII C. Neoclassical French



Art. 541
(photo ref. / rif. foto)

Chair fret carving
end XVIII C. Neoclassical French
Sedia decoro greca
fine XVIII sec. Neoclassico Francese



Decoro
G038 Oro Pitti

DIMENSIONS / DIMENSIONI	
61 x 64 x h 98 cm	
UPHOLSTERY / IMBOTTITURA	
FABRIC / TESSUTO	PE (LEATHER / PELLE)
✓	✓

1191

Half XVIII C. Louis XV



Art. 1191
(photo ref. / rif. foto)

Carver with flowers
half XVIII C. Louis XV
Poltroncina con fiori
metà XVIII sec. Luigi XV



Decoro
G010 Firenze

DIMENSIONS / DIMENSIONI	
76 x 72 x h 104 cm	
CHAIR WITH SEAT CUSHION / SEDIA CON CUSCINO DI SEDUTA	
1191C	
UPHOLSTERY / IMBOTTITURA	
FABRIC / TESSUTO	PE (LEATHER / PELLE)
✓	✓

1198

Half XVIII C. Louis XV



Art. 1198
(photo ref. / rif. foto)

Chair with flowers
half XVIII C. Louis XV
Sedia con fiori
metà XVIII sec. Luigi XV



Decoro
A030 Castagna e Oro

DIMENSIONS / DIMENSIONI	
64 x 65 x h 104 cm	
CHAIR WITH SEAT CUSHION / SEDIA CON CUSCINO DI SEDUTA	
1198C	
UPHOLSTERY / IMBOTTITURA	
FABRIC / TESSUTO	PE (LEATHER / PELLE)
✓	✓

561

XVIII C. Louis XVI French



Art. 561
(photo ref. / rif. foto)

Carver with oak ramage
end XVIII C. Louis XVI French
Poltrona con ramage quercia
fine XVIII Sec. Luigi XVI Francese



Decoro
A014 A.C.O

DIMENSIONS / DIMENSIONI	
59 x 63 x h 95 cm	
UPHOLSTERY / IMBOTTITURA	
FABRIC / TESSUTO	PE (LEATHER / PELLE)
✓	✓

560

End XVIII C. Louis XVI French



Art. 560
(photo ref. / rif. foto)

Chair with oak ramage
end XVIII C. Louis XVI French
Sedia con ramage quercia
fine XVIII Sec. Luigi XVI Francese



Decoro
A014 A.C.O

DIMENSIONS / DIMENSIONI	
51 x 63 x h 95 cm	
UPHOLSTERY / IMBOTTITURA	
FABRIC / TESSUTO	PE (LEATHER / PELLE)
✓	✓

892G

Half XVIII C. Venetian



Art. 892G
(photo ref. / rif. foto)

Carver
half XVIII C. Venetian
Poltroncina
metà XVIII sec. Veneziano



Decoro
G022 Argento Pitti

DIMENSIONS / DIMENSIONI	
60 x 55 x h 105 cm	
UPHOLSTERY / IMBOTTITURA	
FABRIC / TESSUTO	PE (LEATHER / PELLE)
✓	✓

193

Half XVIII C. Venetian



Art. 193
(photo ref. / rif. foto)

Chair
half XVIII C. Venetian
Sedia
metà XVIII Sec. Veneziana

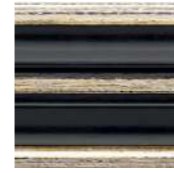

Decoro
G074 Ebony e Argento

DIMENSIONS / DIMENSIONI	
58 x 61 x h 105 cm	
UPHOLSTERY / IMBOTTITURA	
FABRIC / TESSUTO	PE (LEATHER / PELLE)
✓	✓

832

Neoclassical



Art. 832
(photo ref. / rif. foto)

Carver net carving
Neoclassical
Poltrona con schienale a rete
Neoclassico

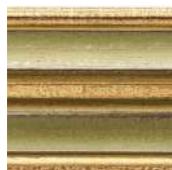

Decoro
G016 Muschio Oro

DIMENSIONS / DIMENSIONI	
58 x 64 x h 96 cm	
UPHOLSTERY / IMBOTTITURA	
FABRIC / TESSUTO	PE (LEATHER / PELLE)
✓	✓

807

Neoclassical



Art. 807
(photo ref. / rif. foto)

Chair net carving
Neoclassical
Sedia con schienale a rete
Neoclassico



Decoro
G016 Muschio Oro

DIMENSIONS / DIMENSIONI	
52 x 64 x h 96 cm	
UPHOLSTERY / IMBOTTITURA	
FABRIC / TESSUTO	PE (LEATHER / PELLE)
✓	✓

340

Half XVIII C. George II English



Art. 340
(photo ref. / rif. foto)

Ball & Claw carver
half XVIII C. George II English
Poltrona Ball & Claw
metà XVIII Sec. Giorgio II Inglese



Decoro
A030 Castagna e Oro

DIMENSIONS / DIMENSIONI	
58 x 67 x h 103 cm	
UPHOLSTERY / IMBOTTITURA	
FABRIC / TESSUTO	PE (LEATHER / PELLE)
✓	✓

339

Half XVIII C. George II English



Art. 339
(photo ref. / rif. foto)

Chair Ball & Claw
half XVIII C. George II English
Sedia Ball & Claw
metà XVIII Sec. Giorgio II Inglese



Decoro
G043 Ebony

DIMENSIONS / DIMENSIONI	
58 x 67 x h 103 cm	
UPHOLSTERY / IMBOTTITURA	
FABRIC / TESSUTO	PE (LEATHER / PELLE)
✓	✓

3101

Neoclassical



Art. 3101
(photo ref. / rif. foto)

Chair with metal handle
Neoclassical
leather upholstery
Sedia con maniglie in metallo
Neoclassica
in pelle



Decoro
G008 Trianon

DIMENSIONS / DIMENSIONI	
56 x 71 x h 98 cm	
UPHOLSTERY / IMBOTTITURA	
FABRIC / TESSUTO	PE (LEATHER / PELLE)
✓	✓

1128

Half XVIII C. Tuscan



Art. 1128
(photo ref. / rif. foto)

Pistoiese chair
half XVIII C. Tuscan
Sedia Pistoiese
metà XVIII Sec. Toscano



Decoro
G012 Greige

DIMENSIONS / DIMENSIONI	
52 x 60 x h 101 cm	
UPHOLSTERY / IMBOTTITURA	
FABRIC / TESSUTO	PE (LEATHER / PELLE)
✓	✓

1232

Half XVIII C. Louis XV Tuscan



Art. 1232
(photo ref. / rif. foto)

Chair with carved handle
half XVIII C. Louis XV Tuscan
Sedia con maniglia intagliata
metà XVIII sec. Luigi XV Toscano



Decoro
G011 Vanwood

DIMENSIONS / DIMENSIONI	
53 x 60 x h 99 cm	
UPHOLSTERY / IMBOTTITURA	
FABRIC / TESSUTO	PE (LEATHER / PELLE)
✓	✓

1273

XVIII C. Tuscan



Art. 1273
(photo ref. / rif. foto)

Chair cuore
XVIII C. Tuscan
Sedia cuore
XVIII sec. Toscano



Decoro
G086 Noir

DIMENSIONS / DIMENSIONI	
52 x 60 x h 100 cm	
UPHOLSTERY / IMBOTTITURA	
FABRIC / TESSUTO	PE (LEATHER / PELLE)
✓	✓

1453

End XVIII C. Neoclassical French



Art. 1453PE
(photo ref. / rif. foto)

Chair
end XVIII C. Neoclassical French
Sedia
fine XVIII Sec. Neoclassico Francese
in pelle



Decoro
G079 Oro Leggero

DIMENSIONS / DIMENSIONI	
72 x 80 x h 107 cm	
UPHOLSTERY / IMBOTTITURA	
FABRIC / TESSUTO	PE (LEATHER / PELLE)
✓	✓

1375

Half XVIII C. Venetian



Art. 1375
(photo ref. / rif. foto)

Desk armchair with wheels
half XVIII C. Venetian
Poltrona per scrivania con ruote
metà XVIII Sec. Veneziano

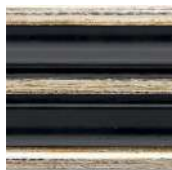

Decoro
G074 Ebony e Argento

DIMENSIONS / DIMENSIONI	
72 x 80 x h 107 cm	
UPHOLSTERY / IMBOTTITURA	
FABRIC / TESSUTO	PE (LEATHER / PELLE)
✓	✓

1268

Half XVIII C. French



Art. 1268PE
(photo ref. / rif. foto)

Leather stool
half XVIII C. French
Sgabello bar in pelle
metà XVIII sec. Francese



Decoro
G043 Ebony

DIMENSIONS / DIMENSIONI			
1268		50 x 48 x h 94 cm	
1268S		50 x 48 x h 81 cm	
UPHOLSTERY / IMBOTTITURA			
FABRIC / TESSUTO		PE (LEATHER / PELLE)	
PLAIN / LISCIO	B (BUTTONED / CAPITONNÉ)	PLAIN / LISCIO	BPE (BUTTONED / CAPITONNÉ)
✓	-	✓	-

STOOLS SGABELLI

337 XIX C. French

Art. 337
(photo ref. / rif. foto)

Stool Malmaison
XIX C. French
Panchetto Malmaison
XIX sec. Francese



Decoro
A041 Impero



DIMENSIONS / DIMENSIONI			
75 x 42 x h 69 cm			
UPHOLSTERY / IMBOTTITURA			
TESSUTO / FABRIC		PE (LEATHER / PELLE)	
PLAIN / LISCIO	B (BUTTONED / CAPITONNÉ)	PLAIN / LISCIO	BPE (BUTTONED / CAPITONNÉ)
✓	-	✓	-

1065 Half XVIII C. Tuscan Borghese

Art. 1065PE
(photo ref. / rif. foto)

Borghese small stool
half XVIII C. Tuscan
Panchetto Borghese
metà XVIII Sec. Toscano



Decoro
G012 Greige



DIMENSIONS / DIMENSIONI				
53 x h 52 cm				
UPHOLSTERY / IMBOTTITURA				
FABRIC / TESSUTO			PE (LEATHER / PELLE)	
PLAIN / LISCIO	B (BUTTONED / CAPITONNÉ)	S (PLISSÉ / PLISSÉ)	PLAIN / LISCIO	BPE (BUTTONED / CAPITONNÉ)
✓	-	✓	✓	-

838B

Half XVII C. Louis XIV



Art. 838B
(photo ref. / rif. foto)

Bench
half XVII C. Louis XIV
Panchetto
metà XVII Sec. Luigi XIV

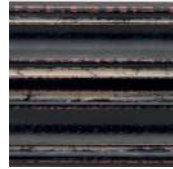

Decoro
G087 Nero Fiammingo

DIMENSIONS / DIMENSIONI			
58 x 58 x h 52 cm			
UPHOLSTERY / IMBOTTITURA			
FABRIC / TESSUTO		PE (LEATHER / PELLE)	
PLAIN / LISCIO	B (BUTTONED / CAPITONNÉ)	PLAIN / LISCIO	BPE (BUTTONED / CAPITONNÉ)
✓	✓	✓	✓

1292

Beg. XIX C. Tuscan



Art. 1292B
(photo ref. / rif. foto)

Buttoned bench
beg XIX C. Tuscan
Sgabello capitonné
inizio XIX Sec. Toscano



Decoro
G012 Greige

DIMENSIONS / DIMENSIONI			
63 x 64 x h 52 cm			
UPHOLSTERY / IMBOTTITURA			
FABRIC / TESSUTO		PE (LEATHER / PELLE)	
PLAIN / LISCIO	B (BUTTONED / CAPITONNÉ)	PLAIN / LISCIO	BPE (BUTTONED / CAPITONNÉ)
✓	✓	✓	✓

697P

End XVIII C. Neoclassical Italian



Art. 697PPE
(photo ref. / rif. foto)

Leather bench
end XVIII C. Neoclassical Italian
Panchetto in pelle
fine XVIII sec. Neoclassico Italiano



Decoro
G079 Oro leggero

DIMENSIONS / DIMENSIONI			
48 x 48 x h 42 cm			
UPHOLSTERY / IMBOTTITURA			
FABRIC / TESSUTO		PE (LEATHER / PELLE)	
PLAIN / LISCIO	B (BUTTONED / CAPITONNÉ)	PLAIN / LISCIO	BPE (BUTTONED / CAPITONNÉ)
✓	-	✓	-

697

End XVIII C. Neoclassical Italian



Art. 697PE
(photo ref. / rif. foto)

Leather bench
end XVIII C. Neoclassical Italian
Panchetto in pelle
fine XVIII sec. Neoclassico Italiano



Decoro
G043 Ebony

DIMENSIONS / DIMENSIONI			
81 x 49 x h 50 cm			
UPHOLSTERY / IMBOTTITURA			
FABRIC / TESSUTO		PE (LEATHER / PELLE)	
PLAIN / LISCIO	B (BUTTONED / CAPITONNÉ)	PLAIN / LISCIO	BPE (BUTTONED / CAPITONNÉ)
✓	-	✓	-

838B

Half XVII C. Louis XIV



1174GS

End XVIII C. Neoclassical Italian



1174

End XVIII C. Neoclassical Italian

Art. 1174S
(photo ref. / rif. foto)

Bench with armrest cover
end XVIII C. Neoclassical Italian
Panchetto con copribraccioli
fine XVIII sec. Neoclassico Italiano

Art. 1174
(photo ref. / rif. foto)

Bench
end XVIII C. Neoclassical Italian
Panchetto
fine XVIII sec. Neoclassico Italiano



Decoro
G035 Oro decapè antico



1174S



1174

DIMENSIONS / DIMENSIONI			
93 x 49 x h 80 cm			
WITH ARMREST COVERS / OPZIONE CON COPRIBRACCIOLI			
1174S			
UPHOLSTERY / IMBOTTITURA			
FABRIC / TESSUTO		PE (LEATHER / PELLE)	
PLAIN / LISCIO	B (BUTTONED / CAPITONNÉ)	PLAIN / LISCIO	BPE (BUTTONED / CAPITONNÉ)
✓	-	✓	-

1174G

End XVIII C. Neoclassical Italian

Art. 1174G
(photo ref. / rif. foto)

Bench
end XVIII C. Neoclassical Italian
Panchetto
fine XVIII sec. Neoclassico Italiano



Decoro
G043 Ebony



DIMENSIONS / DIMENSIONI			
142 x 49 x h 80 cm			
WITH ARMREST COVERS / OPZIONE CON COPRIBRACCIOLI			
1174GS			
UPHOLSTERY / IMBOTTITURA			
FABRIC / TESSUTO		PE (LEATHER / PELLE)	
PLAIN / LISCIO	B (BUTTONED / CAPITONNÉ)	PLAIN / LISCIO	BPE (BUTTONED / CAPITONNÉ)
✓	-	✓	-

691

Beg. XIX C. Impero



Art. 691C
(photo ref. / rif. foto)

Dormeuse with cushion
beg. XIX C. Impero
Dormeuse con cuscino
teste aquile
inizio XIX Sec. Impero



Decoro
A030 Castagna e Oro

DIMENSIONS / DIMENSIONI			
188 x 70 x h 70 cm			
BENCH WITH FIXED PADDING / DORMEUSE CON SEDUTA FISSA			
691			
UPHOLSTERY / IMBOTTITURA			
FABRIC / TESSUTO		PE (LEATHER / PELLE)	
PLAIN / LISCIO	B (BUTTONED / CAPITONNÉ)	PLAIN / LISCIO	BPE (BUTTONED / CAPITONNÉ)
691	-	691	-
691C			

1293

Half XVIII C. Louis XV French



Art. 1293B
(photo ref. / rif. foto)

Buttoned dormeuse
half XVIII C. Louis XV French
Dormeuse capitonné con conchiglia
metà XVIII Sec. Luigi XV Francese



Decoro
G038 Oro Pitti

CUSCREB cushion supplied separately_cuscino CUSCREB fornito a parte

DIMENSIONS / DIMENSIONI			
182 x 74 x h 79 cm			
UPHOLSTERY / IMBOTTITURA			
FABRIC / TESSUTO		PE (LEATHER / PELLE)	
PLAIN / LISCIO	B (BUTTONED / CAPITONNÉ)	PLAIN / LISCIO	BPE (BUTTONED / CAPITONNÉ)
✓	✓	✓	✓

1282

XVIII C. Venetian



Art. 1282
(photo ref. / rif. foto)

Bench 6 legs with shell
XVIII C. Venetian
Panchetto a 6 gambe con conchiglia
XVIII Sec. Veneziano



Decoro
G012 Greige

DIMENSIONS / DIMENSIONI			
164 x 45 x h 52 cm			
UPHOLSTERY / IMBOTTITURA			
FABRIC / TESSUTO		PE (LEATHER / PELLE)	
PLAIN / LISCIO	B (BUTTONED / CAPITONNÉ)	PLAIN / LISCIO	BPE (BUTTONED LEATHER / CAPITONNÉ)
✓	✓	✓	✓

1392

End XVIII C. Tuscan



Art. 1392
(photo ref. / rif. foto)

Bench
end XVIII C. Tuscan
Panchetto
fine XVIII sec. Toscano

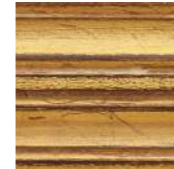

Decoro
G038 Oro Pitti

DIMENSIONS / DIMENSIONI			
162 x 50 x h 83 cm			
UPHOLSTERY / IMBOTTITURA			
FABRIC / TESSUTO		PE (LEATHER / PELLE)	
PLAIN / LISCIO	B (BUTTONED / CAPITONNÉ)	PLAIN / LISCIO	BPE (BUTTONED LEATHER / CAPITONNÉ)
✓	-	✓	-



1352

Half XVIII C. Louis XV French



Art. 1352L

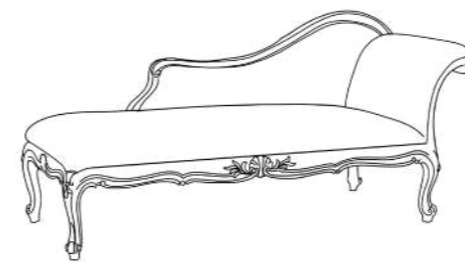

Art. 1352R

(photo ref. / rif. foto)

Dormeuse with right armrest
half XVIII C. Louis XV French
Dormeuse con bracciolo dx
metà XVIII sec. Luigi XV Francese



Decoro
A013 Vogue

DIMENSIONS / DIMENSIONI			
182 x 74 x h 89 cm			
UPHOLSTERY / IMBOTTITURA			
FABRIC / TESSUTO		PE (LEATHER / PELLE)	
PLAIN / LISCIO	B (BUTTONED / CAPITONNÉ)	PLAIN / LISCIO	BPE (BUTTONED LEATHER / CAPITONNÉ)
✓	-	✓	-

601S

Beg. XVIII C. Scottish



Art. 601S
(photo ref. / rif. foto)

Bench 4 legs
beg. XVIII C. Scottish
Panchetto 4 gambe
inizio XVIII sec. Scozzese



Decoro
G043 Ebony

DIMENSIONS / DIMENSIONI			
88 x 49 x h 45 cm			
UPHOLSTERY / IMBOTTITURA			
FABRIC / TESSUTO		PE (LEATHER / PELLE)	
PLAIN / LISCIO	B (BUTTONED / CAPITONNÉ)	PLAIN / LISCIO	BPE (BUTTONED / CAPITONNÉ)
✓	-	✓	-

601

Beg. XVIII C. Scottish



Art. 601C
(photo ref. / rif. foto)

Bench 6 legs
with seat cushion
beg. XVIII C. Scottish
Panchetto 6 gambe
con cuscino di seduta
inizio XVIII sec. Scozzese



Decoro
G038 Oro Pitti

DIMENSIONS / DIMENSIONI			
155 x 49 x h 48 cm			
BENCH WITH FIXED PADDING / PANCHETTO CON SEDUTA FISSA			
601			
UPHOLSTERY / IMBOTTITURA			
FABRIC / TESSUTO		PE (LEATHER / PELLE)	
PLAIN / LISCIO	B (BUTTONED / CAPITONNÉ)	PLAIN / LISCIO	BPE (BUTTONED LEATHER / CAPITONNÉ)
601 601C	601	601	601

341L

Half XVIII C. George II English



Art. 341L
(photo ref. / rif. foto)

Leather buttoned bench Ball & Claw
half XVIII C. George II English
Panchetta Ball & Claw capitonné
in pelle metà XVIII sec.
Giorgio II Inglese



Decoro
G038 Oro Pitti

DIMENSIONS / DIMENSIONI			
130 x 45 x h 43 cm			
UPHOLSTERY / IMBOTTITURA			
FABRIC / TESSUTO		PE (LEATHER / PELLE)	
PLAIN / LISCIO	B (BUTTONED / CAPITONNÉ)	PLAIN / LISCIO	BPE (BUTTONED LEATHER / CAPITONNÉ)
✓	✓	✓	✓

1309

Half XVIII C. Neapolitan



Art. 1309
(photo ref. / rif. foto)

Small bench
half XVIII C. Neapolitan
Panchetto piccolo
metà XVIII Sec. Napoletano



Decoro
G010 Florence

ARTICOLO / ARTICLE	DIMENSIONS / DIMENSIONI		
1309	59 x 43 x h 51 cm		
1309G	106 x 50 x h 45 cm		
UPHOLSTERY / IMBOTTITURA			
FABRIC / TESSUTO		PE (LEATHER / PELLE)	
PLAIN / LISCIO	B (BUTTONED / CAPITONNÉ)	PLAIN / LISCIO	BPE (BUTTONED LEATHER / CAPITONNÉ)
✓	-	✓	-

339P

Half XVIII C. George II English



Art. 339P
(photo ref. / rif. foto)

Stool
half XVIII C. George II English
Sgabello
metà XVIII Sec. Giorgio II Inglese

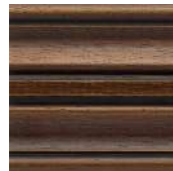

Decoro
G028 Noce

DIMENSIONS / DIMENSIONI			
60 x 40 x h 43 cm			
UPHOLSTERY / IMBOTTITURA			
FABRIC / TESSUTO		PE (LEATHER / PELLE)	
PLAIN / LISCIO	B (BUTTONED / CAPITONNÉ)	PLAIN / LISCIO	BPE (BUTTONED / CAPITONNÉ)
✓	✓	✓	✓

1328

XVIII C. Tuscan



Art. 1328
(photo ref. / rif. foto)

Fiorellacci stool
XVIII C. Tuscan
Panchetto Fiorellacci
XVIII C. sec. Toscano



Decoro
G011 Vanwood

DIMENSIONS / DIMENSIONI			
47 x 43 x h 53 cm			
UPHOLSTERY / IMBOTTITURA			
FABRIC / TESSUTO		PE (LEATHER / PELLE)	
PLAIN / LISCIO	B (BUTTONED / CAPITONNÉ)	PLAIN / LISCIO	BPE (BUTTONED LEATHER / CAPITONNÉ)
✓	-	✓	-

341

Half XVIII C. George II English



Art. 341
(photo ref. / rif. foto)

Stool Ball & Claw
half XVIII C. George II English
Sgabello Ball & Claw
metà XVIII Sec. Giorgio II Inglese



Decoro
A023 Argento

DIMENSIONS / DIMENSIONI			
54 x 44 x h 36 cm			
UPHOLSTERY / IMBOTTITURA			
FABRIC / TESSUTO		PE (LEATHER / PELLE)	
PLAIN / LISCIO	B (BUTTONED / CAPITONNÉ)	PLAIN / LISCIO	BPE (BUTTONED / CAPITONNÉ)
✓	✓	✓	✓

4014



Art. 4014
(photo ref. / rif. foto)

Buttoned cylindrical shape stool
Pouff cilindrico capitonné



Decoro
G038 Oro Pitti

DIMENSIONS / DIMENSIONI			
Ø 50 x h 55 cm			
UPHOLSTERY / IMBOTTITURA			
FABRIC / TESSUTO		PE (LEATHER / PELLE)	
PLAIN / LISCIO	B (BUTTONED / CAPITONNÉ)	PLAIN / LISCIO	BPE (BUTTONED LEATHER / CAPITONNÉ)
-	✓	-	✓

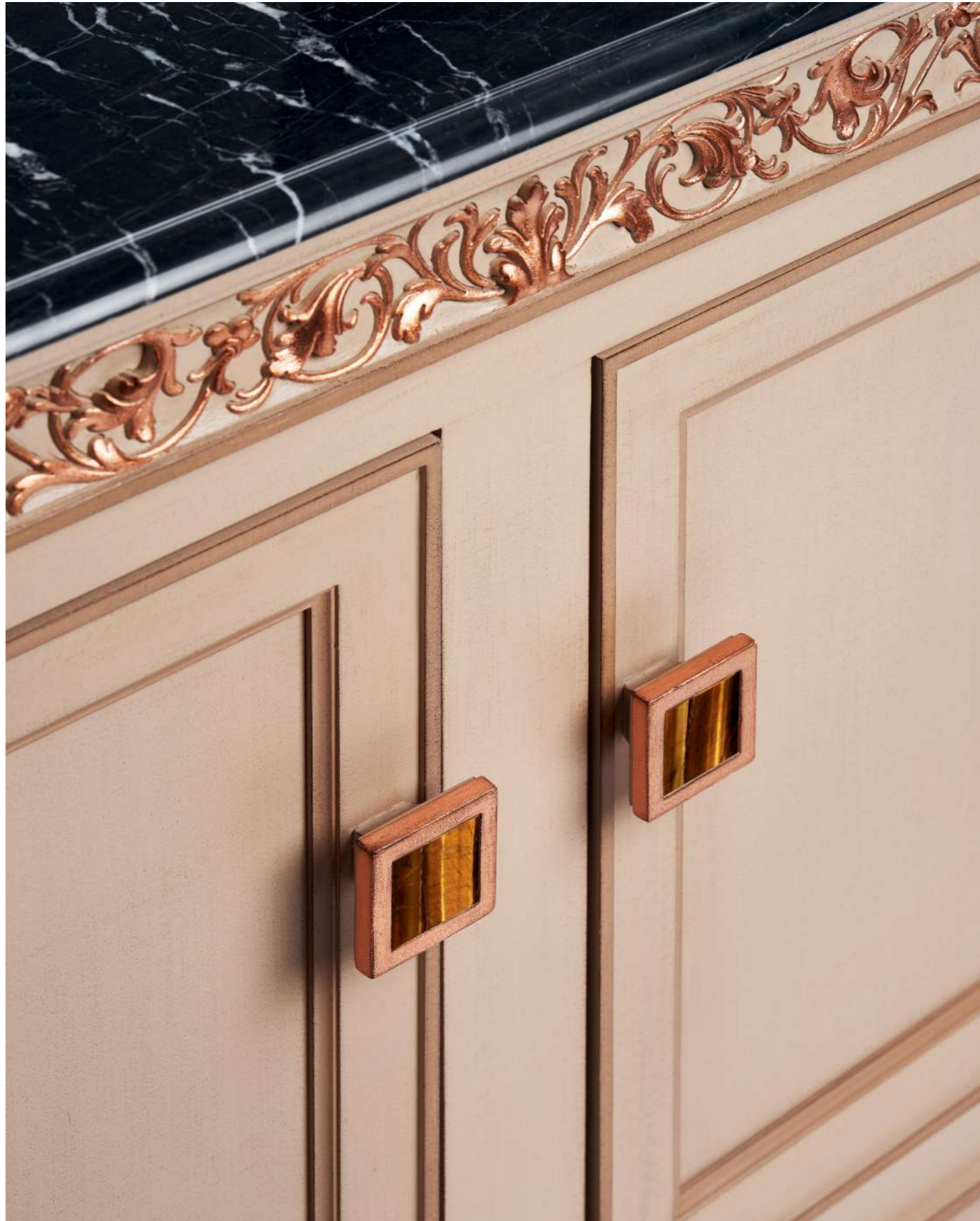

LIVING AREA FURNITURE MOBILI ZONA GIORNO

- SIDEBOARDS
Credenze pag 80
- DISPLAY CABINETS
Vetrine pag 98
- TELEVISION UNITS
Porta TV pag 106



LIVING AREA FURNITURE

MOBILI ZONA GIORNO

The furniture for the living area is divided into sideboards, display cabinets and TV stands and units and is made of carved solid wood; it is available in all finish variants: **Standard, Elite, Luxury**. The visible interiors of the furniture are made with the **Rovere Sbiancato** finish (code G067) or in a colour of our choice to match the exterior finish.

A different finish may be requested, which will be assessed according to feasibility and budgeted separately. The non-visible interiors of the furniture are made in the corresponding colour and painted.

The sideboards are available with two types of top: in wood or in marble chosen from the Roberto Giovannini selection. Options available for some sideboard models:

- Jewelled handles in semi-precious stone
- Bottom of drawers lined with leather (3 colours available: ivory, black, red)
- Internal shelves with smoked glass insert
- LED internal lighting

Options available for some display cabinet models:

- Shelves in wood
- Shelves in extra-clear glass
- Shelves in smoked glass
- Back upholstered in fabric
- LED internal lighting

The TV support frames are sized for 50" or 65" screens, depending on the model, but can be adapted to other screen sizes.

I mobili per la zona giorno si dividono in Credenze, Vetrine e mobili per la TV e sono realizzati in legno massello intagliato; sono disponibili in tutte le varianti di finiture: **Standard, Elite, Luxury**.

Gli interni a vista dei mobili sono realizzati in finitura **Rovere sbiancato** (cod. G067) o in tinta abbinata alla finitura esterna a nostra scelta.

Può essere richiesta una finitura diversa che sarà valutata in base alla fattibilità e preventivata a parte.

Gli interni non a vista dei mobili sono realizzati in tinta e verniciati. Le credenze sono disponibili con due tipologie di piano: in legno o marmo a scelta tra la selezione Roberto Giovannini. Opzioni disponibili su alcuni modelli credenze:

- Maniglie gioiello in pietra semi-preziosa
- Fondo cassette con tappetino in pelle (3 colori disponibili: avorio, nero, rosso)
- Ripiani interni con inserto in vetro fumè
- Illuminazione interna led

Opzioni disponibili su alcuni modelli vetrine:

- Ripiani in legno
- Ripiani in vetro extrachiaro
- Ripiani in vetro fumè
- Rivestimento schienale in tessuto
- Illuminazione interna led

Le cornici porta TV sono dimensionate per schermi da 50" o 65", a seconda dei modelli, ma possono essere adattate ad altre misure di schermo.

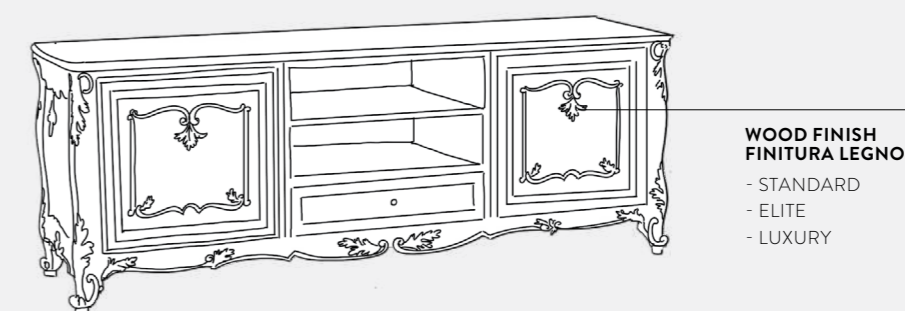
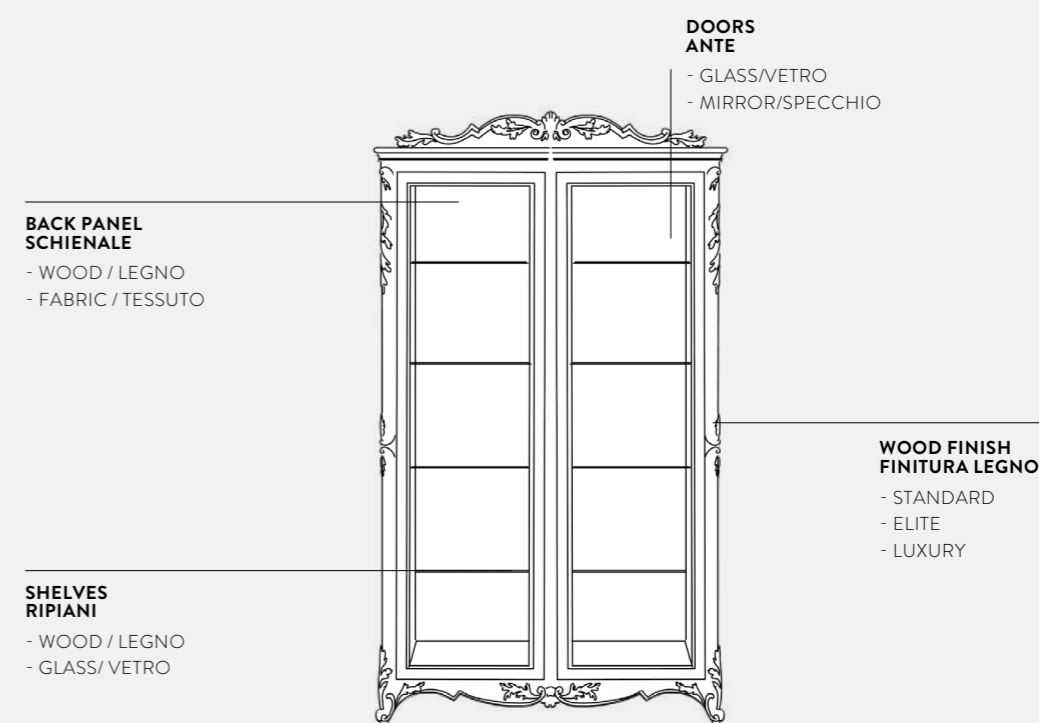

* Some products have optional extras, see dedicated pages. Alcuni prodotti sono dotati di optional, vedi pagine dedicate

** All furniture can be supplied with LED interior lighting on request. Tutti i mobili possono essere forniti con illuminazione interna led su richiesta

535

Beg. XVIII C. Tuscan

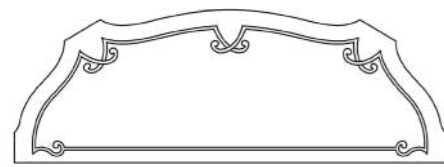

Engraved wooden top_incisione piano legno

Art. 535
(photo ref. / foto ref.)

Medicea sideboard
beg. XVIII C. Tuscan
Credenza Medicea
inizio XVIII Sec. Toscano

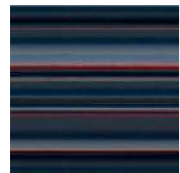

Decoro
G117 Cobalto

DIMENSIONS / DIMENSIONI			
170 x 60 x h 100 cm			
OPTIONS FOR TOPS / VARIANTI PIANO			
WOOD / LEGNO	MARBLE / MARMO		
	STANDARD	ELITE A	ELITE B
✓	✓	✓	✓
EXTRA OPTIONS / OPTIONALS			
JEWELLED HANDLES / MANIGLIE PIETRA	DRAWERS WITH LEATHER / CASSETTI PELLE		
✓	✓		



Living area_furniture_Mobili zona giorno

1274

XVIII C. Tuscan Leopolda



Art. 1274
(photo ref. / foto ref.)

Cabinet 2 doors
XVIII C. Tuscan Leopolda
Mobile vetrina 2 ante
XVIII Sec. Toscano Leopolda



Decoro
G061 Ciliegio e oro

DIMENSIONS / DIMENSIONI

122 x 51 x h 242 cm

1274B

XVIII C. Tuscan Leopolda



Art. 1274B
(photo ref. / foto ref.)

Cupboard 2 doors
XVIII C. Tuscan Leopolda
Credenza 2 ante
XVIII Sec. Toscano Leopolda



Decoro
G079 Oro Leggero

DIMENSIONS / DIMENSIONI

122 x 51 x h 90 cm

1348

XVIII C. Tuscan Leopolda

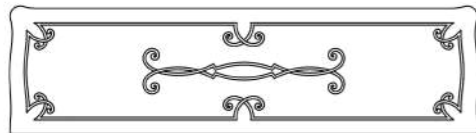

Engraved wooden top_incisione piano legno

Art. 1348
(photo ref. / foto ref.)

Sideboard 3 doors
XVIII C. Tuscan Leopolda
Credenza 3 ante
XVIII Sec. Toscano Leopolda



Decoro
G079 Oro Leggero

DIMENSIONS / DIMENSIONI	
184 x 50 x h 90 cm	
EXTRA OPTIONS / OPTIONALI	
DRAWERS WITH LEATHER / CASSETTI PELLE	
✓	

1270

XVIII C. Tuscan Leopolda



Art. 1270
(photo ref. / foto ref.)

Cabinet 4 doors
XVIII C. Tuscan Leopolda
Mobile con vetrina 4 ante
XVIII Sec. Toscano Leopolda



Decoro
G011 Vanwood

DIMENSIONS / DIMENSIONI	
232 x 51 x h 242 cm	



1270B

XVIII C. Tuscan Leopolda



Art. 1270B
(photo ref. / foto ref.)

Cupboard 4 doors
XVIII C. Tuscan Leopolda
Credenza 4 ante
XVIII Sec. Toscano Leopolda



Decoro
G18 Smoke

DIMENSIONS / DIMENSIONI

232 x 51 x h 90 cm

1401

Neoclassical



Art. 1401
(photo ref. / foto ref.)

2 doors glass cabinet
Neoclassical
Mobile con alzata a 2 ante
Neoclassico

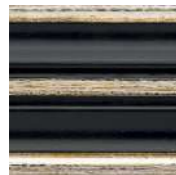

Decoro
G098 Noir e Argento

DIMENSIONS / DIMENSIONI		
143 x 63 x h 224 cm		
EXTRA OPTIONS / OPTIONALI		
JEWELLED HANDLES / MANIGLIE PIETRA	GLASS SHELVES / RIPIANI VETRO	DRAWERS WITH LEATHER / CASSETTI PELLE
✓	✓	✓

1401B

Neoclassical



Art. 1401B
(photo ref. / foto ref.)

2 doors sideboard
Neoclassical
Credenza 2 ante
Neoclassico

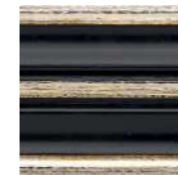

Decoro
G098 Noir e Argento

DIMENSIONS / DIMENSIONI			
129 x 54 x h 91 cm			
OPTIONS FOR TOPS / VARIANTI PIANO			
WOOD / LEGNO	MARBLE / MARMO		
	STANDARD	ELITE A	ELITE B
✓	✓	✓	✓
EXTRA OPTIONS / OPTIONALI			
JEWELLED HANDLES / MANIGLIE PIETRA	GLASS INSERT / VETRO INCASSATO	DRAWERS WITH LEATHER / CASSETTI PELLE	
✓	✓	✓	

1403

Neoclassical



Art. 1403
(photo ref. / foto ref.)

3 doors glass cabinet
Neoclassical
Mobile con alzata 3 ante
Neoclassico



Decoro
G095 Antico Veneziano

DIMENSIONS / DIMENSIONI		
181 x 63 x h 228 cm		
EXTRA OPTIONS / OPTIONALI		
JEWELLED HANDLES / MANIGLIE PIETRA	GLASS SHELVES / RIPIANI VETRO	DRAWERS WITH LEATHER / CASSETTI PELLE
✓	✓	✓

1403B

Neoclassical



Art. 1403B
(photo ref. / foto ref.)

3 doors sideboard
Neoclassical
Credenza 3 ante
Neoclassico



Decoro
G095 Antico Veneziano

DIMENSIONS / DIMENSIONI			
175 x 54 x h 91 cm			
OPTIONS FOR TOPS / VARIANTI PIANO			
WOOD / LEGNO	MARBLE / MARMO		
	STANDARD	ELITE A	ELITE B
✓	✓	✓	✓
EXTRA OPTIONS / OPTIONALI			
JEWELLED HANDLES / MANIGLIE PIETRA	GLASS INSERT / VETRO INCASSATO	DRAWERS WITH LEATHER / CASSETTI PELLE	
✓	✓	✓	



1406

Neoclassical



Art. 1406B
(photo ref. / foto ref.)

4 doors sideboard
Neoclassical
Credenza 4 ante
Neoclassico



Decoro
G115 Cuprum

ARTICLE / ARTICOLO	DIMENSIONS / DIMENSIONI
1406*	250 x 54 x h 228 cm
1406B	245 x 54 x h 91 cm

*4 doors glass cabinet_alzata 4 ante vetro

OPTIONS FOR TOPS / VARIANTI PIANO			
WOOD / LEGNO	MARBLE / MARMO		
	STANDARD	ELITE A	ELITE B
✓	✓	✓	✓

EXTRA OPTIONS / OPTIONALI		
JEWELLED HANDLES / MANIGLIE PIETRA	GLASS INSERT / VETRO INCASSATO	DRAWERS WITH LEATHER / CASSETTI PELLE
✓	✓	✓

1066A

XVIII C. Tuscan



Art. 1066A
(photo ref. / foto ref.)

Ducale corner cupboard
XVIII C. Tuscan
Angoliera ducale
XVIII Sec. Toscano



Decoro
G006 Provence

DIMENSIONS / DIMENSIONI

57 x 97 x h 100 cm

1066

XVIII C. Tuscan



Art. 1066
(photo ref. / foto ref.)

Ducale sideboard
XVIII C. Tuscan
Credenza ducale
XVIII Sec. Toscano



Decoro
G006 Provence

DIMENSIONS / DIMENSIONI

223 x 61 x h 100 cm

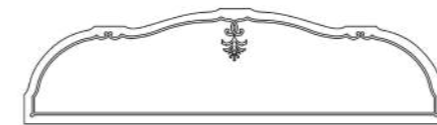

Engraved wooden top_incisione piano legno

1411
XVIII C. Tuscan



Art. 1411
(photo ref. / foto ref.)

3 doors display cabinet
with ornament
XVIII C. Tuscan
Ventrina 3 ante
con frontone
XVIII Sec. Toscano



Decoro
G087 Nero Fiammingo

DIMENSIONS / DIMENSIONI	
184 x 49 x h 204 cm	
EXTRA OPTIONS / OPTIONALS	
GLASS SHELVES / RIPIANI VETRO	
SMOKED / FUMÉ	
EXTRA CLEAR / EXTRA CHIARO	

1411P
XVIII C. Tuscan



Art. 1411P
(photo ref. / foto ref.)

1 door display cabinet
with ornament
XVIII C. Tuscan
Ventrina 1 anta
con frontone
XVIII Sec. Toscano



Decoro
G008 Trianon

DIMENSIONS / DIMENSIONI	
65 x 49 x h 204 cm	
EXTRA OPTIONS / OPTIONALS	
GLASS SHELVES / RIPIANI VETRO	
SMOKED / FUMÉ	
EXTRA CLEAR / EXTRA CHIARO	
	BACK PANEL UPHOSTERED / FONDO RIVESTITO
	✓

1411S
XVIII C. Tuscan



Art. 1411S
(photo ref. / foto ref.)

2 doors display cabinet
with ornament
XVIII C. Tuscan
Ventrina 2 ante
con frontone
XVIII Sec. Toscano

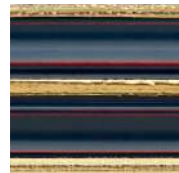

Decoro
G117 Cobalto

DIMENSIONS / DIMENSIONI	
122 x 49 x h 204 cm	
EXTRA OPTIONS / OPTIONALI	
GLASS SHELVES / RIPIANI VETRO SMOKED / FUMÉ EXTRA CLEAR / EXTRA CHIARO	BACK PANEL UPHOSTERED / FONDO RIVESTITO ✓



1015

Half XVIII C. Louis XV French



Art. 1015
(photo ref. / foto ref.)

Book case
half XVIII C. Louis XV French
Vetrinetta
metà XVIII sec. Luigi XV Francese



Decoro
G096 Bianco Fiorentino

DIMENSIONS / DIMENSIONI	
120 x 29 x h 199 cm	
EXTRA OPTIONS / OPTIONALI	
SHELVES / RIPIANI WOOD / LEGNO GLASS / VETRO	BACK PANEL UPHOSTERED / FONDO RIVESTITO FABRIC / TEXTILE MIRROR / SPECCHIO

1367

Beg. XVIII C. Louis XIV Italian



Art. 1367
(photo ref. / foto ref.)

2 doors vitrine
with ornament, glass shelves
and led light inside
beg. XVIII C. Louis XIV Italian
Vetrina 2 ante con frontone
ripiani in vetro e led interno
inizio XVIII Sec. Luigi XIV Italiano



Decoro
G086 Noir

DIMENSIONS / DIMENSIONI	
210 x 50 x h 248 cm	

1439

Neoclassical



Art. 1439
(photo ref. / foto ref.)

3 doors display cabinet
with extra clear glass shelves
Neoclassical
Vetrina 3 ante e ripiani
in vetro extrachiaro
Neoclassico



Decoro
G110 Barocco e Argento

ARTICLE / ARTICOLO	NUMERO VETRINE / NUMERO VETRINE	DIMENSIONS / DIMENSIONI
1439	3 doors / 3 ante	182 x 44 x h 234 cm
1439G	4 doors / 4 ante	240 x 44 x h 234 cm
1439P	2 doors / 2 ante	132 x 44 x h 234 cm

EXTRA OPTIONS / OPTIONALS
GLASS SHELVES / RIPIANI VETRO
SMOKED / FUMÈ
EXTRA CLEAR / EXTRA CHIARO



1337

XVIII C. Tuscan Leopolda



Art. 1337
(photo ref. / foto ref.)

Tv cabinet
XVIII C. Tuscan Leopolda
Mobile porta tv
XVIII Sec. Toscano Leopolda



Decoro
G007 Canova

ARTICLE ARTICOLO	DIMENSIONS / DIMENSIONI
1337	190 x 50 x h 69 cm
1337G	230 x 50 x h 69 cm

1393

XVIII C. Tuscan Leopolda



Art. 1393
(photo ref. / foto ref.)

Tv cabinet 4 doors
XVIII C. Tuscan Leopolda
Mobile porta tv 4 sportelli
XVIII Sec. Toscano Leopolda



Decoro
G007 Canova

DIMENSIONS / DIMENSIONI
300 x 50 x h 69 cm

1380AS

End XVIII C. Neoclassical Italian



Art. 1380AS
(photo ref. / foto ref.)

Tv frame with flowers
end XVIII C. Neoclassical Italian
TV 65" max
Cornice porta TV
fine XVIII Sec. Neoclassico Italiano
TV 65" max



Decoro
A014 A.C.O.

ARTICLE ARTICOLO	DIMENSIONS / DIMENSIONI
1380AS	194 x 25 x h 138 cm
1380AL	194 x 51 x h 138 cm

1381AS

XVII C. Flemish



Art. 1381AS
(photo ref. / foto ref.)

Tv frame
XVII C. Flemish
TV 65" max
Cornice porta TV
XVII Sec. Fiammingo
TV 65" max



Decoro
A014 A.C.O.

ARTICLE ARTICOLO	DIMENSIONS / DIMENSIONI
1380AS	204 x 25 x h 148 cm
1380AL	204 x 51 x h 148 cm



1379AS

2nd half XVII C. Florentine



Art. 1379AS

(photo ref. / foto ref.)

TV frame with shells and shelves
 2nd half XVII C. Florentine
 TV 50" max
 Cornice porta TV con conchiglie
 e mensole
 2° metà XVII Sec. Fiorentino
 TV 50" max



Decoro
 G017 Ciliegio e Argento

ARTICLE ARTICOLO	DIMENSIONS / DIMENSIONI
1379AS	162 x 16,5 x h 162 cm
1379AL	162 x 50 x h 162 cm



SOFAS AND ARMCHAIRS DIVANI E POLTRONE

— SOFAS AND ARMCHAIRS
Divani e poltrone

pag 114



SOFAS AND ARMCHAIRS DIVANI E POLTRONE

The sofas in the collection are made with frames or bases in carved solid wood. Some models are available in different sizes and in matching combination with armchairs; all models are available in all finish variants: **Standard, Elite, Luxury.**

All items in the catalogue can be supplied with upholstery chosen from the Roberto Giovannini "Mosaico" and "Rondò" fabric selections or in neutral-coloured muslin or in the customer's fabric (C.O.M.).

For some articles it is possible to choose a fixed or removable seat cushion (versions only in fabric).

Articles marked with the letter B are made with 'capitonné' padding, the letters PE, on the other hand, indicate craftsmanship in leather, selected from the Roberto Giovannini collection, or supplied by the customer (C.O.M.).

The options for the padding finishes can be:

- Single edge-piping in fabric
- Matching trimmings (RG or supplied by the customer)
- Metal studs (gold, black, chrome, antique effect)

the standard variant for leather coverings (PE)
Certified fire retardant padding is available on request.
Decorative cushions are supplied separately, with single edge-piping or marabout trim to match the fabric.

I divani della collezione sono realizzati con fusti o basi in legno massello intagliato. Alcuni modelli sono disponibili in diverse misure e in abbinamento con le poltrone; tutti i modelli sono disponibili in tutte le varianti di finitura: **Standard, Elite, Luxury.**

Tutti gli articoli a catalogo sono fornibili con rivestimento a scelta tra i tessuti selezione Roberto Giovannini "Mosaico" e "Rondò" oppure in mussolina di colore neutro o tessuto cliente (C.O.M.).

Su alcuni articoli è possibile scegliere la seduta fissa o con cuscino mobile (versioni solo in tessuto).

Gli articoli contraddistinti dalla lettera B sono realizzati con imbottitura "capitonné", le lettere PE, invece, indicano la lavorazione in pelle, selezionata dalla collezione Roberto Giovannini, o fornita dal cliente (C.O.M.).

Le rifiniture delle imbottiture possono essere, a scelta:

- Bordino singolo in tessuto
- Passamaneria a tono (RG o fornita dal cliente)
- Borchie in metallo (oro, nero, cromo, anticato)

Variante standard per lavorazione pelle PE.

Su richiesta è possibile avere imbottiture ignifughe certificate. I cuscini decorativi sono forniti a parte, con rifinitura bordino singolo o marabout in abbinamento al tessuto.

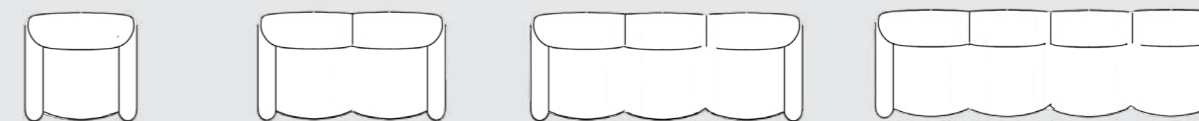

ARMCHAIR
POLTRONA

(S)
2-SEATER SOFA
DIVANO 2 POSTI

3-SEATER SOFA
DIVANO 3 POSTI

(K)
4-SEATER SOFA - KING SIZE
DIVANO 4 POSTI - MISURA KING

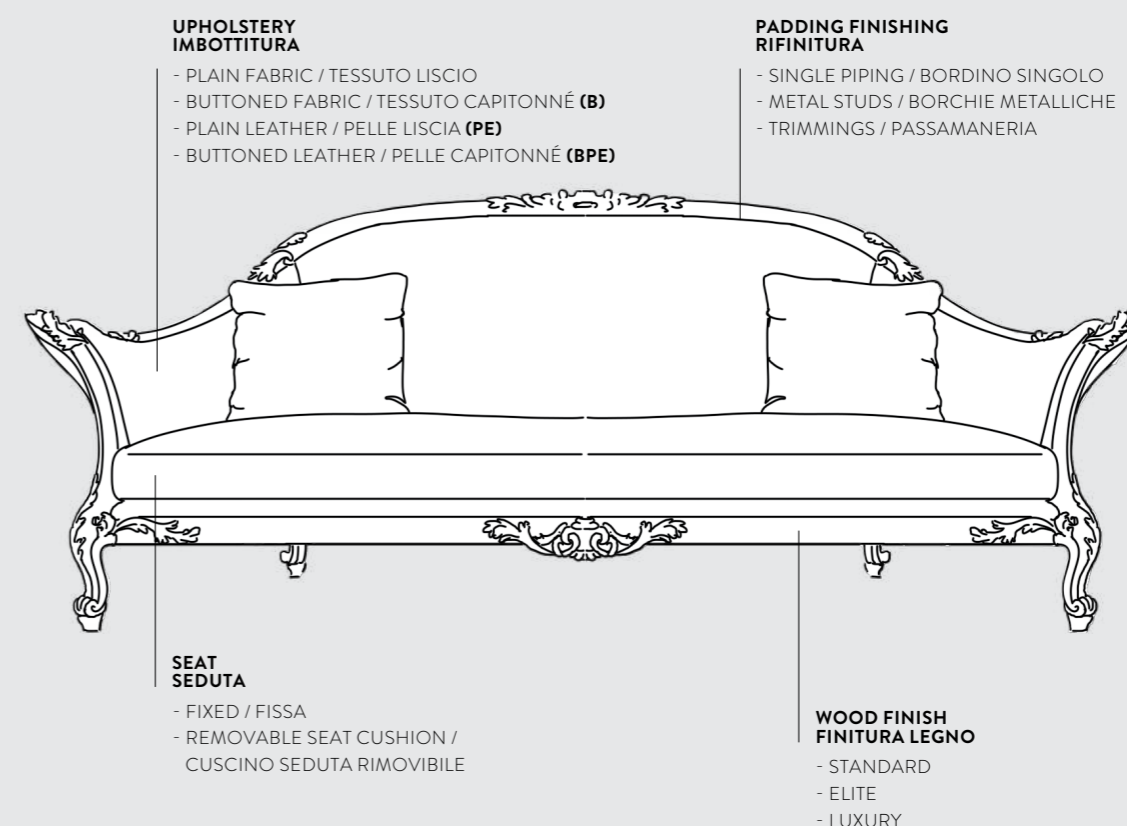

Regency

Beg. XVIII C. Regency French

Art. 1449K



Art. 1449KBPE
(photo ref. / rif. foto)

3 seater sofa
beg. XVIII C. Regency French
Divano 3 posti
inizio XVIII sec. Reggenza Francese



Decoro
G079 Oro Leggero

DIMENSIONS / DIMENSIONI			
310 x 108 x h 120 cm			
UPHOLSTERY / IMBOTTITURA			
FABRIC / TESSUTO		PE (LEATHER / PELLE)	
PLAIN / LISCIO	B (BUTTONED / CAPITONNÉ)*	PLAIN / LISCIO	BPE (BUTTONED / CAPITONNÉ)*
✓	✓	✓	✓

* Only in the armrests_Solo nei braccioli
Decorative cushions supplied separately_cuscini decorativi forniti a parte



Opera

End XVIII C. Neoclassical Italian

Art. 1440



Art. 1440
(photo ref. / rif. foto)

Opera 3 seater sofa
end XVIII C. Neoclassical Italian
Divano Opera 3 posti
fine XVIII sec. Neoclassico Italiano



Decoro
G079 Oro Leggero

DIMENSIONS / DIMENSIONI			
268 x 124 x h 100 cm			
UPHOLSTERY / IMBOTTITURA			
FABRIC / TESSUTO		PE (LEATHER / PELLE)	
PLAIN / LISCIO	B (BUTTONED / CAPITONNÉ)	PLAIN / LISCIO	BPE (BUTTONED / CAPITONNÉ)
✓	-	✓	-

Opera

End XVIII C. Neoclassical Italian

Art. 1441



Art. 1441
(photo ref. / rif. foto)

Opera Armchair
end XVIII C. Neoclassical Italian
Poltrona Opera
fine XVIII sec. Neoclassico Italiano



Decoro
G079 Oro Leggero

DIMENSIONS / DIMENSIONI			
141 x 120 x h 98 cm			
UPHOLSTERY / IMBOTTITURA			
FABRIC / TESSUTO		PE (LEATHER / PELLE)	
PLAIN / LISCIO	B (BUTTONED / CAPITONNÉ)	PLAIN / LISCIO	BPE (BUTTONED / CAPITONNÉ)
✓	-	✓	-

Augustus

Neoclassical

Art. 1383B



Art. 1383B
(photo ref. / rif. foto)

3-seater
Neoclassical
buttoned sofa
Divano imbottito capitonné
Neoclassico
3 posti



Decoro
G081 Oro antiquariato

S 2-SEATER SOFA DIVANO 2 POSTI	3-SEATER SOFA DIVANO 3 POSTI	K 4-SEATER KING SOFA DIVANO KING 4 POSTI
211 x 102 x h 96 cm	250 x 102 x h 96 cm	310 x 102 x h 96 cm

UPHOLSTERY / IMBOTTITURA			
FABRIC / TESSUTO		PE (LEATHER / PELLE)	
PLAIN / LISCIO	B (BUTTONED / CAPITONNÉ)	PLAIN / LISCIO	BPE (BUTTONED / CAPITONNÉ)
-	✓	-	✓

Decorative cushions supplied separately_cuscini decorativi forniti a parte

Augustus

Neoclassical

Art. 1384B



Art. 1384B
(photo ref. / rif. foto)

Buttoned armchair
Neoclassical
Poltrona imbottita capitonné
Neoclassico



Decoro
G081 Oro antiquariato

DIMENSIONS / DIMENSIONI			
130 x 106 x h 100 cm			

UPHOLSTERY / IMBOTTITURA			
FABRIC / TESSUTO		PE (LEATHER / PELLE)	
PLAIN / LISCIO	B (CAPITONNÉ)	PLAIN / LISCIO	BPE (BUTTONED / CAPITONNÉ)
-	✓	-	✓

Decorative cushions supplied separately_cuscini decorativi forniti a parte

De' Medici

Half XVIII C. Louis XV Tuscan

Art. 1404



Art. 1404

(photo ref. / rif. foto)

3 seater sofa
half XVIII C. Louis XV Tuscan
Divano 3 posti
metà XVIII sec. Luigi XV Toscano



Decoro
G035 Oro Decapè Antico

S 2-SEATER SOFA DIVANO 2 POSTI	3-SEATER SOFA DIVANO 3 POSTI	K KING SOFA DIVANO KING
208 x 110 x h 101 cm	246 x 110 x h 101 cm	310 x 110 x h 101 cm

UPHOLSTERY / IMBOTTITURA			
FABRIC / TESSUTO		PE (LEATHER / PELLE)	
PLAIN / LISCIO	B (BUTTONED / CAPITONNÉ)	PLAIN / LISCIO	BPE (BUTTONED / CAPITONNÉ)
✓	-	✓	-

Decorative cushions supplied separately_cuscini decorativi forniti a parte

De' Medici

Half XVIII C. Louis XV Tuscan

Art. 1405



Art. 1405

(photo ref. / rif. foto)

Armchair
half XVIII C. Louis XV Tuscan
Poltrona
metà XVIII sec. Luigi XV Toscano



Decoro
G035 Oro Decapè Antico

DIMENSIONS / DIMENSIONI			
122 x 110 x h 101 cm			

UPHOLSTERY / IMBOTTITURA			
FABRIC / TESSUTO		PE (LEATHER / PELLE)	
PLAIN / LISCIO	B (BUTTONED / CAPITONNÉ)	PLAIN / LISCIO	BPE (BUTTONED / CAPITONNÉ)
✓	-	✓	-

Decorative cushions supplied separately_cuscini decorativi forniti a parte

Savoy

Half XVIII C. Neoclassical Piedmontese

Art. 1417MT



Art. 1417MT
(photo ref. / rif. foto)

Savoy sofa 3 seater
half XVIII C.
Neoclassical Piedmontese
Divano Savoy 3 posti
metà XVIII sec.
Neoclassico Piemontese



Decoro
G079 Oro Leggero

S 2-SEATER SOFA DIVANO 2 POSTI	3-SEATER SOFA DIVANO 3 POSTI	K 4-SEATER KING SOFA DIVANO KING 4 POSTI
220 x 95 x h 106 cm	255 x 95 x h 106 cm	315 x 95 x h 106 cm

UPHOLSTERY / IMBOTTITURA			
FABRIC / TESSUTO		PE (LEATHER / PELLE)	
PLAIN / LISCIO	B (BUTTONED / CAPITONNÉ)	PLAIN / LISCIO	BPE (BUTTONED / CAPITONNÉ)
✓	-	-	-

Savoy

Half XVIII C. Neoclassical Piedmontese

Art. 1422MT



Art. 1422MT
(photo ref. / rif. foto)

Savoy armchair with seat cushion
half XVIII C.
Neoclassical Piedmontese
Poltrona Savoy
metà XVIII sec.
Neoclassico Piemontese



Decoro
G079 Oro Leggero

DIMENSIONS / DIMENSIONI			
103 x 95 x h 102 cm			

UPHOLSTERY / IMBOTTITURA			
FABRIC / TESSUTO		PE (LEATHER / PELLE)	
PLAIN / LISCIO	B (BUTTONED / CAPITONNÉ)	PLAIN / LISCIO	BPE (BUTTONED / CAPITONNÉ)
✓	-	-	-

Savoy
Half XVIII C. Neoclassical Piedmontese
Art. 1417MT



Savoy Carved

Half XVIII C. Neoclassical Piedmontese

Art. 1417K



Art. 1417CK
(photo ref. / rif. foto)

3 seater sofa
half XVIII C.
Neoclassical Piedmontese
Divano 3 posti
metà XVIII sec.
Neoclassico Piemontese



Decoro
A111 Perlage

DIMENSIONS / DIMENSIONI			
255 x 95 x h 106 cm			
REMOVABLE SEAT CUSHION / CUSCINO DI SEDUTA RIMOVIBILE		FIXED SEAT / SEDUTA FISSA	
✓		✓	
UPHOLSTERY / IMBOTTITURA			
FABRIC / TESSUTO		PE (LEATHER / PELLE)	
PLAIN / LISCIO	B (BUTTONED / CAPITONNÉ)	PLAIN / LISCIO	BPE (BUTTONED / CAPITONNÉ)
✓	-	-	-

Savoy Carved

Half XVIII C. Neoclassical Piedmontese

Art. 1422C



Art. 1422C
(photo ref. / rif. foto)

Armchair
half XVIII C.
Neoclassical Piedmontese
Poltrona 3 posti
metà XVIII sec.
Neoclassico Piemontese

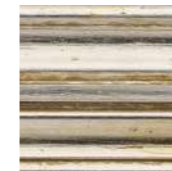

Decoro
A111 Perlage

DIMENSIONS / DIMENSIONI			
101 x 95 x h 100 cm			
REMOVABLE SEAT CUSHION / CUSCINO DI SEDUTA RIMOVIBILE		FIXED SEAT / SEDUTA FISSA	
✓		✓	
UPHOLSTERY / IMBOTTITURA			
FABRIC / TESSUTO		PE (LEATHER / PELLE)	
PLAIN / LISCIO	B (BUTTONED / CAPITONNÉ)	PLAIN / LISCIO	BPE (BUTTONED / CAPITONNÉ)
✓	-	-	-

Luigi XV
Half XVIII C. Venetian
Art. 1362C



Art. 1362C
(photo ref. / rif. foto)

3 seaters pozzetto sofa
half XVIII sec. Venetian
Divano pozzetto 3 posti
metà XVIII sec. Veneziano



Decoro
G094 Prestige

DIMENSIONS / DIMENSIONI			
213 x 116 x h 101 cm			
REMOVABLE SEAT CUSHION / CUSCINO DI SEDUTA RIMOVIBILE		FIXED SEAT / SEDUTA FISSA	
✓		✓	
UPHOLSTERY / IMBOTTITURA			
FABRIC / TESSUTO		PE (LEATHER / PELLE)	
PLAIN / LISCIO	B (BUTTONED / CAPITONNÉ)	PLAIN / LISCIO	BPE (BUTTONED / CAPITONNÉ)
✓	-	-	-

Decorative cushions supplied separately_cuscini decorativi forniti a parte

Luigi XV
Half XVIII C. Venetian
Art. 1333



Art. 1333
(photo ref. / rif. foto)

Armchair
half XVIII C. Venetian
Poltrona
metà XVIII sec. Veneziano



Decoro
G079 Oro Leggero

DIMENSIONS / DIMENSIONI			
90 x 91 x h 104 cm			
UPHOLSTERY / IMBOTTITURA			
FABRIC / TESSUTO		PE (LEATHER / PELLE)	
PLAIN / LISCIO	B (BUTTONED / CAPITONNÉ)	PLAIN / LISCIO	BPE (BUTTONED / CAPITONNÉ)
✓	-	✓	-

Decorative cushions supplied separately_cuscini decorativi forniti a parte

Pitti

Half XVIII C. Louis XV French

Art. 1104



Art. 1104CK
(photo ref. / rif. foto)

Pitti sofa
half XVIII C. Louis XV French
Divano Pitti
metà XVIII sec. Luigi XV Francese



Decoro
A036 Oro Antico

3-SEATER SOFA DIVANO 3 POSTI		K KING SOFA DIVANO KING	
215 x 86 x h 90 cm		250 x 102 x h 102 cm	
C REMOVABLE SEAT CUSHION / CUSCINO DI SEDUTA		FIXED SEAT / SEDUTA FISSA	
1104C 1104CK		1104 1104K	
UPHOLSTERY / IMBOTTITURA			
FABRIC / TESSUTO		PE (LEATHER / PELLE)	
PLAIN / LISCIO	B (BUTTONED / CAPITONNÉ)	PLAIN / LISCIO	BPE (BUTTONED / CAPITONNÉ)
✓	-	-	-

Decorative cushions supplied separately_cuscini decorativi forniti a parte

Pitti

Half XVIII C. Louis XV French

Art. 1200



Art. 1200C
(photo ref. / rif. foto)

Pitti armchair
half XVIII C. Louis XV French
Poltrona Pitti
metà XVIII sec. Luigi XV Francese



Decoro
G043 Ebony

DIMENSIONS / DIMENSIONI			
120 x 85 x h 95 cm			
C REMOVABLE SEAT CUSHION / CUSCINO DI SEDUTA RIMOVIBILE		FIXED SEAT / SEDUTA FISSA	
✓		✓	
UPHOLSTERY / IMBOTTITURA			
FABRIC / TESSUTO		PE (LEATHER / PELLE)	
PLAIN / LISCIO	B (BUTTONED / CAPITONNÉ)	PLAIN / LISCIO	BPE (BUTTONED / CAPITONNÉ)
✓	-	-	-

Toscano

Half XVII C. Louis XIV Italian

Art. 1262



Art. 1262CK
(photo ref. / rif. foto)

Sofa
half XVII C. Louis XIV Italian
Divano
metà XVII sec. Luigi XIV Italiano



Decoro
G079 Oro Leggero

SOFA		4-SEATER KING SOFA DIVANO KING 4 POSTI	
220 x 88 x h 101 cm		250 x 98 x h 102 cm	
REMOVABLE SEAT CUSHION / CUSCINO DI SEDUTA RIMOVIBILE		FIXED SEAT / SEDUTA FISSA	
1262C 1262CK		1262 1262K	
UPHOLSTERY / IMBOTTITURA			
FABRIC / TESSUTO		PE (LEATHER / PELLE)	
PLAIN / LISCIO	B (BUTTONED / CAPITONNÉ)	PLAIN / LISCIO	BPE (BUTTONED / CAPITONNÉ)
✓	-	-	-

Toscano

Half XVII C. Louis XIV Italian

Art. 1264



Art. 1264C
(photo ref. / rif. foto)

Armchair
half XVII C. Louis XIV Italian
Poltrona
metà XVII sec. Luigi XIV Italiano



Decoro
G038 Oro Pitti

DIMENSIONS / DIMENSIONI			
123 x 94 x h 102 cm			
REMOVABLE SEAT CUSHION / CUSCINO DI SEDUTA RIMOVIBILE		FIXED SEAT / SEDUTA FISSA	
✓		✓	
UPHOLSTERY / IMBOTTITURA			
FABRIC / TESSUTO		PE (LEATHER / PELLE)	
PLAIN / LISCIO	B (BUTTONED / CAPITONNÉ)	PLAIN / LISCIO	BPE (BUTTONED / CAPITONNÉ)
✓	-	-	-

Veneziano

XVIII C. Venetian

Art. 1221



Art. 1221C
(photo ref. / rif. foto)

2 seaters sofa
XVIII C. Venetian
Divanetto a pozzetto 2 posti
XVIII sec. Veneziano



Decoro
G009 Blanc

DIMENSIONS / DIMENSIONI			
146 x 85 x h 93 cm			
REMOVABLE SEAT CUSHION / CUSCINO DI SEDUTA RIMOVIBILE		FIXED SEAT / SEDUTA FISSA	
✓		✓	
UPHOLSTERY / IMBOTTITURA			
FABRIC / TESSUTO		PE (LEATHER / PELLE)	
PLAIN / LISCIO	B (BUTTONED / CAPITONNÉ)	PLAIN / LISCIO	BPE (BUTTONED / CAPITONNÉ)
✓	-	-	-

Decorative cushions supplied separately_cuscini decorativi forniti a parte

Veneziano

XVIII C. Venetian

Art. 1225



Art. 1225C
(photo ref. / rif. foto)

Armchair
XVIII C. Venetian
Poltroncina
XVIII sec. Veneziano



Decoro
A030 Castagna e oro

DIMENSIONS / DIMENSIONI			
81 x 82 x h 96 cm			
REMOVABLE SEAT CUSHION / CUSCINO DI SEDUTA RIMOVIBILE		FIXED SEAT / SEDUTA FISSA	
✓		✓	
UPHOLSTERY / IMBOTTITURA			
FABRIC / TESSUTO		PE (LEATHER / PELLE)	
PLAIN / LISCIO	B (BUTTONED / CAPITONNÉ)	PLAIN / LISCIO	BPE (BUTTONED / CAPITONNÉ)
✓	-	-	-

Neoclassico
End XVIII C. Neoclassical
Art. 1314S



Art. 1314S
(photo ref. / rif. foto)

2 seaters sofa
end XVIII C. Neoclassical
Divano 2 posti
fine XVIII sec. Neoclassico



Decoro
G067 Rovere sbiancato

DIMENSIONS / DIMENSIONI			
151 x 90 x h 107 cm			
UPHOLSTERY / IMBOTTITURA			
FABRIC / TESSUTO		PE (LEATHER / PELLE)	
PLAIN / LISCIO	B (BUTTONED / CAPITONNÉ)	PLAIN / LISCIO	BPE (BUTTONED / CAPITONNÉ)
✓	-	-	-

Neoclassico
End XVIII C. Neoclassical
Art. 1317



Art. 1317
(photo ref. / rif. foto)

Armchair
end XVIII C. Neoclassical
Poltrona
fine XVIII sec. Neoclassico



Decoro
G096 Bianco Fiorentino

DIMENSIONS / DIMENSIONI			
92 x 89 x h 107 cm			
UPHOLSTERY / IMBOTTITURA			
FABRIC / TESSUTO		PE (LEATHER / PELLE)	
PLAIN / LISCIO	B (BUTTONED / CAPITONNÉ)	PLAIN / LISCIO	BPE (BUTTONED / CAPITONNÉ)
✓	-	-	-

Decorative cushions supplied separately_cuscini decorativi forniti a parte

Genovese

XVIII C. Genoese

Art. 676



Art. 676
(photo ref. / rif. foto)

Sofa
XVIII C. Genoese
Divano
XVIII sec. Genovese



Decoro
G088 Rosso e Argento

DIMENSIONS / DIMENSIONI			
170 x 78 x h 93 cm			
REMOVABLE SEAT CUSHION / CUSCINO DI SEDUTA RIMOVIBILE		FIXED SEAT / SEDUTA FISSA	
✓		✓	
UPHOLSTERY / IMBOTTITURA			
FABRIC / TESSUTO		PE (LEATHER / PELLE)	
PLAIN / LISCIO	B (BUTTONED / CAPITONNÉ)	PLAIN / LISCIO	BPE (BUTTONED / CAPITONNÉ)
✓	-	-	-

Genovese

XVIII C. Genoese

Art. 676P



Art. 676P
(photo ref. / rif. foto)

Armchair
XVIII C. Genoese
Poltrona
XVIII sec. Genovese



Decoro
G003 Magnolia

DIMENSIONS / DIMENSIONI			
108 x 78 x h 93 cm			
REMOVABLE SEAT CUSHION / CUSCINO DI SEDUTA RIMOVIBILE		FIXED SEAT / SEDUTA FISSA	
✓		✓	
UPHOLSTERY / IMBOTTITURA			
FABRIC / TESSUTO		PE (LEATHER / PELLE)	
PLAIN / LISCIO	B (BUTTONED / CAPITONNÉ)	PLAIN / LISCIO	BPE (BUTTONED / CAPITONNÉ)
✓	-	-	-

Vis à Vis
Half XVIII C. Venetian
Art. 1291



Art. 1291
(photo ref. / rif. foto)

Vis à vis sofà
half XVIII C. Venetian
Divano vis à vis
metà XVIII sec. Veneziano



Decoro
G038 Oro Pitti

DIMENSIONS / DIMENSIONI			
197 x 91 x h 102 cm			
UPHOLSTERY / IMBOTTITURA			
FABRIC / TESSUTO		PE (LEATHER / PELLE)	
PLAIN / LISCIO	B (BUTTONED / CAPITONNÉ)	PLAIN / LISCIO	BPE (BUTTONED / CAPITONNÉ)
✓	-	✓	-

Decorative cushions supplied separately_cuscini decorativi forniti a parte





Bergère
Half XVIII C. Louis XV
Art. 1009



Art. 1009
(photo ref. / rif. foto)

Bergère
half XVIII C. Louis XV
Bergère
metà XVIII sec. Luigi XV



Decoro
G086 Noir

DIMENSIONS / DIMENSIONI			
75 x 88 x h 104 cm			
UPHOLSTERY / IMBOTTITURA			
FABRIC / TESSUTO		PE (LEATHER / PELLE)	
PLAIN / LISCIO	B (BUTTONED / CAPITONNÉ)	PLAIN / LISCIO	BPE (BUTTONED / CAPITONNÉ)
✓	✓	✓	✓

Grand Bergère

Half XVIII C. Louis XV

Art. 1009G



Art. 1009G
(photo ref. / rif. foto)

Bergère
half XVIII C. Louis XV
Bergère
metà XVIII sec. Luigi XV



Decoro
G079 Oro Leggero

DIMENSIONS / DIMENSIONI			
101 x 103 x h 106 cm			
UPHOLSTERY / IMBOTTITURA			
FABRIC / TESSUTO		PE (LEATHER / PELLE)	
PLAIN / LISCIO	B (BUTTONED / CAPITONNÉ)	PLAIN / LISCIO	BPE (BUTTONED / CAPITONNÉ)
✓	-	-	-

Bergère bench

Half XVIII C. Louis XV

Art. 1010



Art. 1010
(photo ref. / rif. foto)

Bench
half XVIII C. Louis XV
Panchetto
metà XVIII sec. Luigi XV



Decoro
G067 Rovere sbiancato

DIMENSIONS / DIMENSIONI			
76 x 65 x h 48 cm			
UPHOLSTERY / IMBOTTITURA			
FABRIC / TESSUTO		PE (LEATHER / PELLE)	
PLAIN / LISCIO	B (BUTTONED / CAPITONNÉ)	PLAIN / LISCIO	BPE (BUTTONED / CAPITONNÉ)
✓	-	-	-

Grand Bergère bench

Half XVIII C. Louis XV

Art. 1010G



Art. 1010G
(photo ref. / rif. foto)

Bench
half XVIII C. Louis XV
Panchetto
metà XVIII sec. Luigi XV



Decoro
G043 Ebony

DIMENSIONS / DIMENSIONI			
97 x 66 x h 48 cm			
UPHOLSTERY / IMBOTTITURA			
FABRIC / TESSUTO		PE (LEATHER / PELLE)	
PLAIN / LISCIO	B (BUTTONED / CAPITONNÉ)	PLAIN / LISCIO	BPE (BUTTONED / CAPITONNÉ)
✓	-	✓	-

Augusta

Half XVIII C. Louis XVI

Art. 1376



Art. 1376

(photo ref. / rif. foto)

Armchair
half XVIII C. Louis XVI
Poltrona da salotto
metà XVIII sec. Luigi XVI



Decoro
G096 Bianco Fiorentino

DIMENSIONS / DIMENSIONI			
76 x 86 x h 104 cm			
UPHOLSTERY / IMBOTTITURA			
FABRIC / TESSUTO		PE (LEATHER / PELLE)	
PLAIN / LISCIO	B (BUTTONED / CAPITONNÉ)	PLAIN / LISCIO	BPE (BUTTONED / CAPITONNÉ)
✓	-	✓	-

Philippa

Half XIX C. Louis Philip

Art. 1258



Art. 1258

(photo ref. / rif. foto)

Armchair
half XIX C. Louis Philip
Poltrona
metà XIX sec. Luigi Filippo

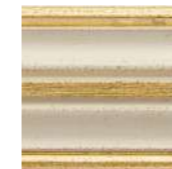

Decoro
G003 Magnolia

DIMENSIONS / DIMENSIONI			
97 x 93 x h 95 cm			
REMOVABLE SEAT CUSHION / CUSCINO DI SEDUTA RIMOVIBILE		FIXED SEAT / SEDUTA FISSA	
✓		✓	
UPHOLSTERY / IMBOTTITURA			
FABRIC / TESSUTO		PE (LEATHER / PELLE)	
PLAIN / LISCIO	B (BUTTONED / CAPITONNÉ)	PLAIN / LISCIO	BPE (BUTTONED / CAPITONNÉ)
✓	-	-	-

Marquise

Half XVIII C. Louis XV

Art. 1349



Art. 1349SC
(photo ref. / rif. foto)

Marquise with back rest cushion
half XVIII C. Louis XV
Marquise con cuscino schienale
metà XVIII sec. Luigi XV



Decoro
G079 Oro Leggero

DIMENSIONS / DIMENSIONI			
100 x 104 x h 103 cm			
ARMCHAIR WITH REMOVABLE CUSHIONS / POLTRONA CON CUSCINI MOBILI		ARMCHAIR WITH REMOVABLE SEAT CUSHION / POLTRONA CON CUSCINO DI SEDUTA	
1349SC		 1349	
UPHOLSTERY / IMBOTTITURA			
FABRIC / TESSUTO		PE (LEATHER / PELLE)	
PLAIN / LISCIO	B (BUTTONED / CAPITONNÉ)	PLAIN / LISCIO	BPE (BUTTONED / CAPITONNÉ)
✓	-	-	-

Louis

End XVIII C. Louis XVI

Art. 454



Art. 454
(photo ref. / rif. foto)

Carver with oval back
end XVIII C. Louis XVI
Poltroncina con schienale ovale
fine XVIII sec. Luigi XVI



Decoro
G035 Oro decapè antico

DIMENSIONS / DIMENSIONI			
69 x 75 x h 101 cm			
UPHOLSTERY / IMBOTTITURA			
FABRIC / TESSUTO		PE (LEATHER / PELLE)	
PLAIN / LISCIO	B (BUTTONED / CAPITONNÉ)	PLAIN / LISCIO	BPE (BUTTONED / CAPITONNÉ)
✓	-	✓	-



Duchesse

Half XVIII C. Neoclassical Neapolitan

Art. 1423



Art. 1423
(photo ref. / rif. foto)

Duchesse armchair
half XVIII C.
Neoclassical Neapolitan
Poltroncina Duchesse
metà XVIII sec.
Neoclassico Napoletano



Decoro
G096 Bianco Fiorentino

DIMENSIONS / DIMENSIONI

91 x 80 x h 102 cm

UPHOLSTERY / IMBOTTITURA

FABRIC / TESSUTO		PE (LEATHER / PELLE)	
PLAIN / LISCIO	B (BUTTONED / CAPITONNÉ)	PLAIN / LISCIO	BPE (BUTTONED / CAPITONNÉ)
✓	-	-	-

CUSHIONS CUSCINI

CUSHION FINISHES / RIFINITURE



SINGLE PIPING / BORDINO



GALA 7 CM / GALA 7 CM



MARABOUT / MARABOUT

CUSHION FINISHES ARE AVAILABLE ON ALL PILLOW TYPES EXCEPT THE CYLINDER PILLOW AND ROUND PILLOW
LE RIFINITURE SONO DISPONIBILI SU TUTTI I TIPI DI CUSCINO AD ECCEZIONE DEL CUSCINO A CILINDRO E DEL CUSCINO TONDO

Cilindro

Art. CUSCC

Cylinder cushion
Cuscino cilindrico

DIMENSIONS / DIMENSIONI			
CUSCCA	CUSCCC	CUSCCD	CUSCCB
80 x Ø 20 cm	85 x Ø 20 cm	95 x Ø 20 cm	45 x Ø 20 cm



Quadrato

Art. CUSCQ

Square cushion
Cuscino quadrato

DIMENSIONS / DIMENSIONI		
CUSCQA	CUSCQB	CUSCQC
40 x 40 cm	50 x 50 cm	60 x 60 cm



Rettangolare

Art. CUSCR - CUSCRCB

Art. CUSCR
Rectangular cushion
Cuscino rettangolare

DIMENSIONS / DIMENSIONI					
CUSCRA	CUSCRE	CUSCRB	CUSCRC	CUSCRF	CUSCRD
45 x 35 cm	50 x 30 cm	60 x 40 cm	70 x 30 cm	70 x 40 cm	70 x 50 cm



Art. CUSCRCB
Rectangular buttoned cushion
Cuscino rettangolare con bottoni

DIMENSIONS / DIMENSIONI	
CUSCRCB	
70 x 30 cm	



Tondo

Art. CUSCT

Round cushion
Cuscino rotondo

DIMENSIONS / DIMENSIONI		
CUSCTB		
Ø 40 cm	Ø 50 cm	Ø 60 cm





COFFEE AND SIDE TABLES TAVOLINI

— COFFEE TABLES
Tavolini da caffè

pag 158

— SIDE TABLES
Tavolini lato divano

pag 172



COFFE AND SIDE TABLES TAVOLINI

The coffee and side tables are made of carved solid wood and are available in all finish variants: **Standard, Elite, Luxury**. They are available with three types of top: in wood, glass or marble selected from the Roberto Giovannini collection.

I tavolini da caffè e lato divano sono realizzati in legno massello intagliato e sono disponibili in tutte le varianti di finitura: **Standard, Elite, Luxury**. Sono forniti con tre tipologie di piano: in **legno, vetro o marmo** a scelta tra la selezione Roberto Giovannini.

COFFE TABLES_TAVOLINI DA CAFFÉ

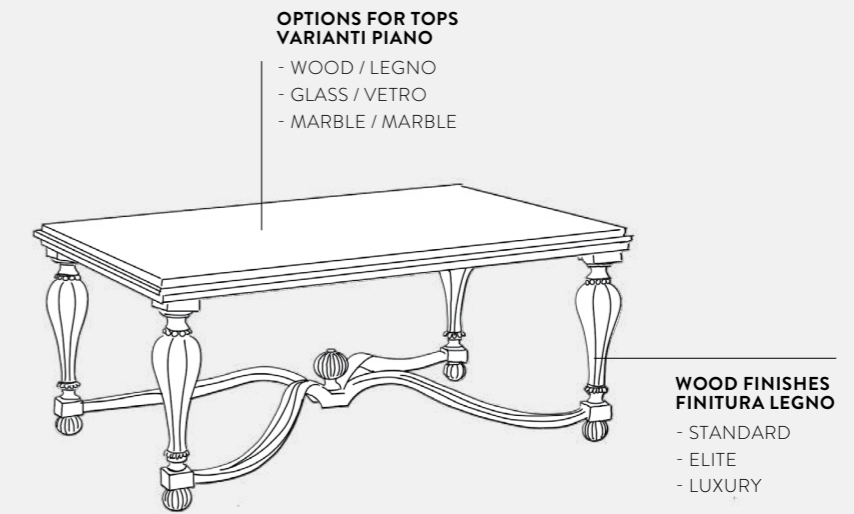

SIDE TABLES_TAVOLINI LATO DIVANO

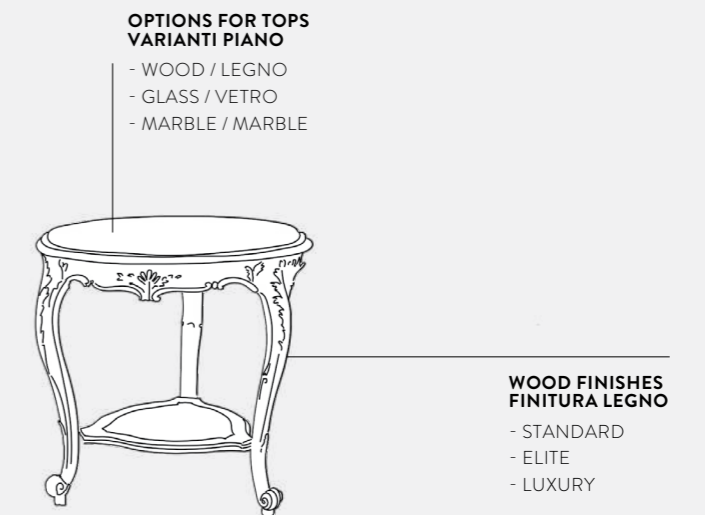

1428

Neoclassical Piedmontese

Art. 1428

(photo ref. / foto ref.)

4 legs rectangular coffee table
end XVIII C.
Neoclassical Piedmontese
Tavolino da caffè rettangolare
4 gambe
fine XVIII Sec.
Neoclassico Piemontese



Decoro
G079 Oro Leggero



Art. 1428GK

(photo ref. / foto ref.)

6 legs rectangular coffee table
end XVIII C.
Neoclassical Piedmontese
Tavolino da caffè rettangolare
6 gambe
fine XVIII Sec.
Neoclassico Piemontese



Decoro
G079 Oro Leggero

ARTICLE / ARTICOLO	DIMENSIONS / DIMENSIONI
1428	149 x 97 x h 51,5 cm
1428G	149 x 149 x h 51,5 cm
1428GP	97 x 97 x h 51,5 cm
1428GK*	183 x 149 x h 51,5 cm

TABLE TOP OPTIONS / VARIANTI PIANO					
WOOD / LEGNO	GLASS / VETRO	COLORED / RETROVERNICIATO	MARBLE / MARMO		
			STANDARD	ELITE A	ELITE B
✓	✓	✓	✓	✓	✓

* 6 legs element_ elemento a 6 gambe



1427

End XVIII C. Neoclassical Piedmontese

Art. 1427
(photo ref. / foto ref.)

Rectangular coffee table with garlands end XVIII C. Neoclassical Piedmontese
Tavolino da caffè rettangolare con ghirlande fine XVIII Sec. Neoclassico Piemontese



Decoro A077 Oro Francese



ARTICLE / ARTICOLO	DIMENSIONS / DIMENSIONI
1427	148 x 97 x h 50 cm
1427G	148 x 148 x h 50 cm
1427GP	97 x 97 x h 50 cm

TABLE TOP OPTIONS / VARIANTI PIANO				
WOOD / LEGNO	GLASS / VETRO	MARBLE / MARMO		
		STANDARD	ELITE A	ELITE B
✓	✓	✓	✓	✓

1390

XVIII C. Italian

Art. 1390G
(photo ref. / foto ref.)

Square coffee table with leaves XVIII C. Italian
Tavolino quadrato con intreccio foglie XVIII Sec. Italiano



Decoro G081 Oro Antiquariato



ARTICLE / ARTICOLO	DIMENSIONS / DIMENSIONI
1390	147,5 x 116,5 x h 48 cm
1390G	147,5 x 147,5 x h 48 cm

TABLE TOP OPTIONS / VARIANTI PIANO				
WOOD / LEGNO	COLOURED GLASS / VETRO RETROVERNICIATO	MARBLE / MARMO		
		STANDARD	ELITE A	ELITE B
✓	✓	✓	✓	✓



1247

Half XVIII C. Louis XV French

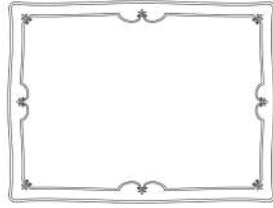

Engraved wooden top_incisione piano legno

Art. 1247

(photo ref. / foto ref.)

Rectangular coffee table
half XVIII C. Louis XV French
Tavolino rettangolare
metà XVIII Sec. Luigi XV Francese

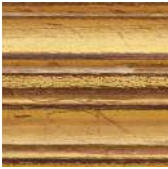

Decoro
G038 Oro Pitti



DIMENSIONS / DIMENSIONI				
135 x 103 x h 49 cm				
TABLE TOP OPTIONS / VARIANTI PIANO				
WOOD / LEGNO	GLASS / VETRO	MARBLE / MARMO		
		STANDARD	ELITE A	ELITE B
✓	✓	✓	✓	✓

1247G

End XVIII C. Louis XV French

Art. 1247G

(photo ref. / foto ref.)

Square coffee table
half XVIII C. Louis XV French
Tavolino quadrato
metà XVIII Sec. Luigi XV Francese

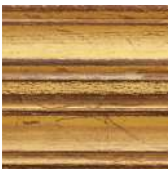

Decoro
G038 Oro Pitti



DIMENSIONS / DIMENSIONI					
135 x 135 x h 49 cm					
TABLE TOP OPTIONS / VARIANTI PIANO					
WOOD / LEGNO	GLASS / VETRO	COLORED GLASS / RETROVERNICIATO	MARBLE / MARMO		
			STANDARD	ELITE A	ELITE B
✓	✓	✓	✓	✓	✓

276

End XVIII C.

Art. 276

(photo ref. / foto ref.)

Oak coffee table
end XVIII C.
Tavolino a quercia
fine XVIII Sec.

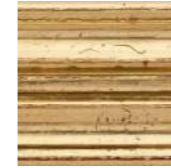

Decoro
A039 Oro Versailles



DIMENSIONS / DIMENSIONI				
130 x 79 x h 45 cm				
TABLE TOP OPTIONS / VARIANTI PIANO				
WOOD / LEGNO	GLASS / VETRO	MARBLE / MARMO		
		STANDARD	ELITE A	ELITE B
-	✓	-	-	-

1019

End XVIII C.

Art. 1019

(photo ref. / foto ref.)

Oval coffee table with oak leaves
end XVIII C.
Tavolino ovale a quercia
fine XVIII Sec.



Decoro
G032 Pickled Pine Oro



DIMENSIONS / DIMENSIONI				
133 x 98 x h 53 cm				
TABLE TOP OPTIONS / VARIANTI PIANO				
WOOD / LEGNO	GLASS / VETRO	MARBLE / MARMO		
		STANDARD	ELITE A	ELITE B
-	✓	-	-	-



1346

End XVIII C. Piemontese

Art. 1346

(photo ref. / foto ref.)

Round coffee table with cross-bar
end XVIII C. Piemontese
Tavolino tondo con crociata
fine XVIII Sec. Piemontese



Decoro
G011 Vanwood



ARTICLE / ARTICOLO	DIMENSIONS / DIMENSIONI
1346	Ø150 x h 48 cm
1346P	Ø120 x h 48 cm

TABLE TOP OPTIONS / VARIANTI PIANO				
WOOD / LEGNO	GLASS / VETRO	MARBLE / MARMO		
		STANDARD	ELITE A	ELITE B
-	✓	-	-	-

1402

End XVIII C. Louis XVI French

Art. 1402

(photo ref. / foto ref.)

Round coffee table
end XVIII C. Louis XVI French
Tavolino tondo da caffè
fine XVIII Sec. Luigi XVI Francese



Decoro
G035 Oro Decapè antico



DIMENSIONS / DIMENSIONI
Ø147 x h 51 cm

TABLE TOP OPTIONS / VARIANTI PIANO				
WOOD / LEGNO	GLASS / VETRO	MARBLE / MARMO		
		STANDARD	ELITE A	ELITE B
✓	✓	✓	✓	✓

1069

Half XVII C. Louis XIV French



Art. 1069
(photo ref. / foto ref.)

Rectangular coffee table marble top
half XVII C. Louis XIV French
Tavolo rettangolare piano marmo
metà XVII Sec. Luigi XIV Francese



Decoro
G010 Firenze

DIMENSIONS / DIMENSIONI				
129 x 79 x h 52 cm				
TABLE TOP OPTIONS / VARIANTI PIANO				
WOOD / LEGNO	GLASS / VETRO	MARBLE / MARMO		
		STANDARD	ELITE A	ELITE B
✓	✓	✓	✓	✓

1043

End XVIII C. Neoclassical



Art. 1043
(photo ref. / foto ref.)

Coffee table with bottom shelf
and bottom shelf
end XVIII C. Neoclassical
Tavolino con sottopiano
fine XVIII Sec. Neoclassico



Decoro
A021 Argento Soleil Decapè

DIMENSIONS / DIMENSIONI				
124 x 74 x h 48 cm				
TABLE TOP OPTIONS / VARIANTI PIANO				
WOOD / LEGNO	GLASS / VETRO	MARBLE / MARMO		
		STANDARD	ELITE A	ELITE B
✓	✓	✓	✓	✓

626

XVIII C. Scottish



Art. 626
(photo ref. / foto ref.)

Cross-bar coffee table marble top
XVIII C. Scottish
Tavolino piano marmo con crociata
XVIII Sec. Scozzese



Decoro
G022 Argento Pitti

DIMENSIONS / DIMENSIONI				
106 x 68 x h 45 cm				
TABLE TOP OPTIONS / VARIANTI PIANO				
WOOD / LEGNO	GLASS / VETRO	MARBLE / MARMO		
		STANDARD	ELITE A	ELITE B
✓	✓	✓	✓	✓

1138

Half XVIII C. Louis XV



Art. 1138
(photo ref. / foto ref.)

Rectangular coffee table
with wooden bottom shelf
half XVIII C. Louis XV
Tavolino rettangolare
con sottopiano in legno
metà XVIII Sec. Luigi XV



Decoro
A029 Bolo e Oro

DIMENSIONS / DIMENSIONI				
124 x 75 x h 49 cm				
GLASS BOTTOM SHELF / SOTTOPIANO VETRO				
1138V				
TABLE TOP OPTIONS / VARIANTI PIANO				
WOOD / LEGNO	GLASS / VETRO	MARBLE / MARMO		
		STANDARD	ELITE A	ELITE B
✓	✓	✓	✓	✓

1139

Half XVIII C. Louis XV French

Art. 1139

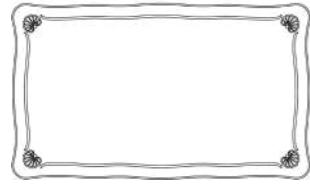

Engraved wooden top, incisione piano legno



Art. 1139
(photo ref. / foto ref.)

Coffee table with shell
half XVIII C. Louis XV French
Tavolino conchiglia
metà XVIII Sec. Luigi XV Francese



Decoro
G042 Ebony e Oro

DIMENSIONS / DIMENSIONI				
116 x 69 x h 46 cm				
TOP TABLE OPTIONS / VARIANTI PIANO				
WOOD / LEGNO	GLASS / VETRO	MARBLE / MARMO		
		STANDARD	ELITE A	ELITE B
✓	-	-	-	-

1431

End XVIII C. Neoclassical Piedmontese

Art. 1431
(photo ref. / foto ref.)

6 legs round coffee table
end XVIII C.
Neoclassical Piedmontese
Tavolino da caffè rotondo
6 gambe
fine XVIII Sec.
Neoclassico Piemontese



DIMENSIONS / DIMENSIONI				
Ø127 x h 47 cm				
TOP TABLE OPTIONS / VARIANTI PIANO				
WOOD / LEGNO	GLASS / VETRO	MARBLE / MARMO		
		STANDARD	ELITE A	ELITE B
✓	✓	✓	✓	✓



Decoro
G038 Oro Pitti



Small tables_favolini

SIDE TABLES LATO DIVANO

1425
End XVIII C. Louis XVI French



Art. 1425
(photo ref. / foto ref.)
Round side table
end XVIII C. Louis XVI French
Tavolino lato divano
fine XVIII Sec. Luigi XVI Francese



Decoro
A077 Oro Francese

DIMENSIONS / DIMENSIONI				
Ø83 x h 73 cm				

TABLE TOP OPTIONS / VARIANTI PIANO				
WOOD / LEGNO	GLASS / VETRO	MARBLE / MARMO		
		STANDARD	ELITE A	ELITE B
✓	-	✓	✓	✓



1388

End XVIII C. Neoclassical Italian

Art. 1388
(photo ref. / foto ref.)

Round side table
end XVIII C. Neoclassical Italian
Tavolino tondo
fine XVIII Sec. Neoclassico Italiano



Decoro
A077 Oro Francese



DIMENSIONS / DIMENSIONI

Ø75 x h 73 cm

TABLE TOP OPTIONS / VARIANTI PIANO

WOOD / LEGNO	GLASS / VETRO	MARBLE / MARMO		
		STANDARD	ELITE A	ELITE B
✓	-	✓	✓	✓

1389

End XVIII C. Neoclassical Piedmontese

Art. 1389
(photo ref. / foto ref.)

Round side table
end XVIII C.
Neoclassical Piedmontese
Tavolino tondo
fine XVIII Sec.
Neoclassico Piemontese



Decoro
G035 Oro Decapè Antico



DIMENSIONS / DIMENSIONI

Ø75 x h 74 cm

TABLE TOP OPTIONS / VARIANTI PIANO

WOOD / LEGNO	GLASS / VETRO	MARBLE / MARMO		
		STANDARD	ELITE A	ELITE B
✓	-	✓	✓	✓

1416

End XVIII C. Neoclassical Piedmontese



Art. 1416
(photo ref. / foto ref.)

Oval side table
end XVIII C. Neoclassical Piedmontese
Tavolino ovale lato divano
fine XVIII Sec. Neoclassico Piemontese



Decoro
G079 Oro Leggero

DIMENSIONS / DIMENSIONI					
79 x 65 x h 70,5 cm					
TABLE TOP OPTIONS / VARIANTI PIANO					
WOOD / LEGNO	GLASS / VETRO	COLORED GLASS / RETROVERNICIATO	MARBLE / MARMO		
			STANDARD	ELITE A	ELITE B
✓	✓	✓	✓	✓	✓

1141

Half XVIII C. Louis XV



Art. 1141
(photo ref. / foto ref.)

Round side table
with wooden bottom shelf
half XVIII C. Louis XV
Tavolino tondo
con sottopiano in legno
metà XVIII Sec. Luigi XV

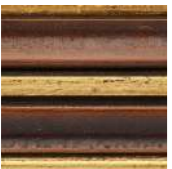

Decoro
A029 Bolo e Oro

DIMENSIONS / DIMENSIONI				
Ø72 x h 72 cm				
TABLE TOP OPTIONS / VARIANTI PIANO				
WOOD / LEGNO	GLASS / VETRO	MARBLE / MARMO		
		STANDARD	ELITE A	ELITE B
✓	✓	✓	✓	✓

1100

1st half XIX C. Biedermeier



Art. 1100
(photo ref. / foto ref.)

Occasional table
1st half XIX C. Biedermeier
Tavolino
1° metà XIX Sec. Biedermeier



Decoro
G010 Florence

DIMENSIONS / DIMENSIONI				
Ø76 x h 74 cm				
TABLE TOP OPTIONS / VARIANTI PIANO				
WOOD / LEGNO	GLASS / VETRO	MARBLE / MARMO		
		STANDARD	ELITE A	ELITE B
✓	-	✓	✓	✓

1085

End XVIII C. Neoclassical



Art. 1085
(photo ref. / foto ref.)

Reel occasional table
end XVIII C. Neoclassical
Tavolo a rocchetto
fine XVIII Sec. Neoclassico

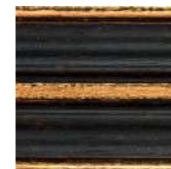

Decoro
G042 Ebony e Oro

DIMENSIONS / DIMENSIONI				
Ø75 x h 74 cm				
TABLE TOP OPTIONS / VARIANTI PIANO				
WOOD / LEGNO	GLASS / VETRO	MARBLE / MARMO		
		STANDARD	ELITE A	ELITE B
✓	-	✓	✓	✓

1178

End XVIII C. Neoclassical

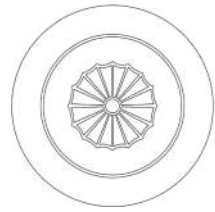

Engraved wooden top, incisione piano legno

Art. 1178
(photo ref. / foto ref.)

Tray coffee table
end XVIII C. Neoclassical
Tavolino tondo con vassoio
fine XVIII Sec. Neoclassico



Decoro
G006 Provence



DIMENSIONS / DIMENSIONI
Ø64 x h 64 cm

596

Beg. XIX C. Empire French

Art. 596
(photo ref. / foto ref.)

Occasional table marble top
with eagles head
beg. XIX C. Empire French
Tavolino piano marmo
con aquila
inizio XIX Sec. Impero Francese



Decoro
G088 Rosso Argento



DIMENSIONS / DIMENSIONI
Ø74 x h 72 cm

TABLE TOP OPTIONS / VARIANTI PIANO				
WOOD / LEGNO	GLASS / VETRO	MARBLE / MARMO		
		STANDARD	ELITE A	ELITE B
✓	✓	✓	✓	✓

1102

XVIII C. Louis XV

Art. 1102
(photo ref. / foto ref.)

Occasional table with grapes
half XVIII C. Louis XV
Tavolino 3 gambe grappolo
metà XVIII Sec. Luigi XV



Decoro
A029 Bolo e Oro



DIMENSIONS / DIMENSIONI
Ø61 x h 72 cm

TABLE TOP OPTIONS / VARIANTI PIANO				
WOOD / LEGNO	GLASS / VETRO	MARBLE / MARMO		
		STANDARD	ELITE A	ELITE B
✓	✓	✓	✓	✓

1251

Half XVIII C. Louis XV French

Art. 1251
(photo ref. / foto ref.)

Round side table
wooden bottom shelf
half XVIII C. Louis XV French
Tavolino sottopiano in legno
metà XVIII Sec. Luigi XV Francese



Decoro
G038 Oro Pitti



DIMENSIONS / DIMENSIONI
Ø72 x h 70 cm

TABLE TOP OPTIONS / VARIANTI PIANO					
WOOD / LEGNO	GLASS / VETRO	COLORED GLASS / RETROVERNICIATO	MARBLE / MARMO		
			STANDARD	ELITE A	ELITE B
✓	✓	✓	✓	✓	✓

1024

XVIII C. Neoclassical

Art. 1024
(photo ref. / foto ref.)

Occasional table
with pineapple carving
end XVIII C. Neoclassical
Tavolino sottopiano
con decoro ananas
fine XVIII Sec. Neoclassico



Decoro
A021 Argento Soleil Decapè



DIMENSIONS / DIMENSIONI				
Ø74 x h 72 cm				
TABLE TOP OPTIONS / VARIANTI PIANO				
WOOD / LEGNO	GLASS / VETRO	MARBLE / MARMO		
		STANDARD	ELITE A	ELITE B
✓	✓	✓	✓	✓

1313

XVIII C. Tuscan

Art. 1313
(photo ref. / foto ref.)

Round side table
XVIII C. Tuscan
Tavolino tondo
XVIII Sec. Toscano



Decoro
G011 Vanwood



DIMENSIONS / DIMENSIONI				
Ø72 x h 72 cm				
TABLE TOP OPTIONS / VARIANTI PIANO				
WOOD / LEGNO	GLASS / VETRO	MARBLE / MARMO		
		STANDARD	ELITE A	ELITE B
✓	✓	✓	✓	✓

1340

Half XVIII C. Piedmontese

Art. 1340
(photo ref. / foto ref.)

Side table with trifol carving
half XVIII C. Piedmontese
Tavolino lato divano con trifoglio
metà XVIII Sec. Piemontese



Decoro
G006 Provence



DIMENSIONS / DIMENSIONI	
Ø66 x h 64 cm	

1053

End XVIII C. Neoclassical English

Art. 1053
(photo ref. / foto ref.)

Stem side table marble top
end XVIII C. Neoclassical English
Tavolino a stelo piano marmo
fine XVIII Sec. Neoclassico Inglese



Decoro
G094 Prestige



DIMENSIONS / DIMENSIONI	
Ø40 x h 62 cm	

TABLE TOP OPTIONS / VARIANTI PIANO				
WOOD / LEGNO	GLASS / VETRO	MARBLE / MARMO		
		STANDARD	ELITE A	ELITE B
✓	-	✓	✓	✓

1063

Half XVII C. Louis XIV French

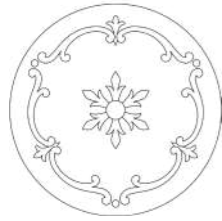

Engraved wooden top_incisione piano legno

Art. 1063
(photo ref. / foto ref.)

Small table 3 legs with engraved top
half XVII C. Louis XIV French
Tavolino 3 gambe piano inciso
metà XVII Sec. Luigi XIV Francese



Decoro
A029 Bolo e Oro



DIMENSIONS / DIMENSIONI

Ø47 x h 67 cm

1073

Half XIX C. Louis Philip

Art. 1073
(photo ref. / foto ref.)

Stem side table marble top
with garland
half XIX C. Louis Philip
Tavolino a stelo piano marmo
con ghirlanda
metà XIX Sec. Luigi Filippo



Decoro
A014 A.C.O.



DIMENSIONS / DIMENSIONI

Ø40 x h 65 cm

TABLE TOP OPTIONS / VARIANTI PIANO

WOOD / LEGNO	GLASS / VETRO	MARBLE / MARMO		
		STANDARD	ELITE A	ELITE B
✓	-	✓	✓	✓

704

End XVIII C. Neoclassical

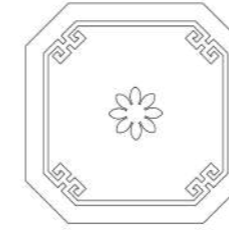

Engraved wooden top_incisione piano legno

Art. 704
(photo ref. / foto ref.)

Octagonal serving stand 3 legs
end XVIII C. Neoclassical
Tavolino 3 gambe servomuto
ottagonale
fine XVIII Sec. Neoclassico



Decoro
A040 Napoleon



DIMENSIONS / DIMENSIONI

41 x 41 x h 67 cm

704R

End XVIII C. Neoclassical

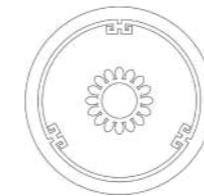

Engraved wooden top_incisione piano legno

Art. 704R
(photo ref. / foto ref.)

Round serving stand 3 legs
end XVIII C. Neoclassical
Tavolino 3 gambe servomuto tondo
fine XVIII Sec. Neoclassico



Decoro
A041 Impero



DIMENSIONS / DIMENSIONI

Ø48 x h 67 cm

740P

XVIII C. Scottish

Art. 740P

(photo ref. / foto ref.)

Occasional table marble top
3 legs and cross-bar
XVIII C. Scottish
Tavolino piano marmo
3 gambe e crociata
XVIII Sec. Scozzese



Decoro
A040 Napoleon



DIMENSIONS / DIMENSIONI				
Ø61 x h 60 cm				
TABLE TOP OPTIONS / VARIANTI PIANO				
WOOD / LEGNO	GLASS / VETRO	MARBLE / MARMO		
		STANDARD	ELITE A	ELITE B
✓	✓	✓	✓	✓

501

Beg. XIX C. Empire French

Art. 501

(photo ref. / foto ref.)

Side table 3 arrows
beg. XIX C. Empire French
Tavolino 3 frecce
inizio XIX Sec. Impero Francese



Decoro
A041 Impero



DIMENSIONS / DIMENSIONI				
Ø54 x h 58 cm				
TABLE TOP OPTIONS / VARIANTI PIANO				
WOOD / LEGNO	GLASS / VETRO	MARBLE / MARMO		
		STANDARD	ELITE A	ELITE B
✓	✓	✓	✓	✓

1288

XIX C. Napoleon III French

Art. 1288

(photo ref. / foto ref.)

3 legs side table
XIX C. Napoleon III French
Tavolino 3 gambe
XIX Sec. Napoleone III Francese



Decoro
G038 Oro Pitti



DIMENSIONS / DIMENSIONI	
Ø40 x h 70 cm	

342

Beg. XIX C. Empire

Art. 342

(photo ref. / foto ref.)

Laces side table
beg. XIX C. Empire
Tavolino con lacci
inizio XIX Sec. Impero



Decoro
A077 Oro Francese



DIMENSIONS / DIMENSIONI				
Ø56 x h 56 cm				
TABLE TOP OPTIONS / VARIANTI PIANO				
WOOD / LEGNO	GLASS / VETRO	MARBLE / MARMO		
		STANDARD	ELITE A	ELITE B
-	✓	✓	✓	✓

1320

End XVIII C. Neoclassical



Art. 1320

(photo ref. / foto ref.)

Side table with flower end XVIII C. Neoclassical
Tavolino fiore cornice fine XVIII Sec. Neoclassico



Decoro
G011 Vanwood

DIMENSIONS / DIMENSIONI				
58 x 58 x h 67 cm				
TABLE TOP OPTIONS / VARIANTI PIANO				
WOOD / LEGNO	GLASS / VETRO	MARBLE / MARMO		
		STANDARD	ELITE A	ELITE B
✓	-	-	-	-

1072

Half XVII C. Louis XIV



Art. 1072

(photo ref. / foto ref.)

Square coffee table marble top
half XVII C. Louis XIV
Tavolino quadrato piano marmo
metà XVII Sec. Luigi XIV



Decoro
G010 Florence

DIMENSIONS / DIMENSIONI				
62 x 62 x h 67 cm				
TABLE TOP OPTIONS / VARIANTI PIANO				
WOOD / LEGNO	GLASS / VETRO	MARBLE / MARMO		
		STANDARD	ELITE A	ELITE B
✓	✓	✓	✓	✓





MIRROR FRAMES SPECCHIERE

— MIRROR FRAMES
Specchiere

pag 190

RG

MIRROR FRAMES SPECCHIERE

The mirror frames in the collection are made of carved solid wood, and are available in all finish variants: **Standard, Elite, Luxury**. And for three types of mirror: plain, bevelled or antique effect.

Some models can be further customised by adding, around the edges or in the passe-partout, coloured-glass inserts or semi-precious stones .

Le specchiere della collezione sono realizzate in legno massello intagliato, sono disponibili in tutte le varianti finitura: **Standard, Elite, Luxury**. Tra tre tipologie di specchio: **liscio, molato o anticato**. Alcuni modelli possono essere personalizzati ulteriormente inserendo nelle parti laterali o nel passe-par-tout, fasce di vetro colorato o pietre semi-preziose.

MIRROR FRAMES_SPECCHIERE

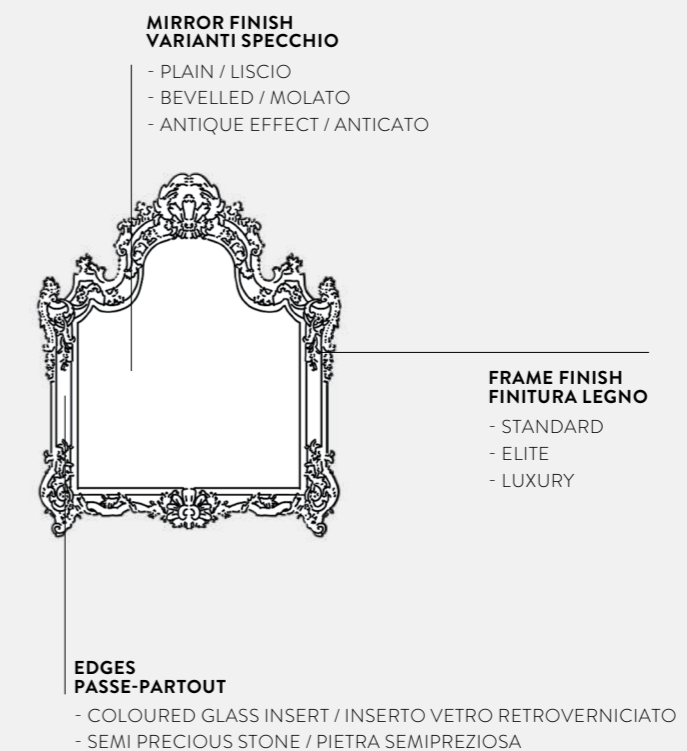

282GK

Half XVIII C. Louis XV French



Art. 282GK
(photo ref. / foto ref.)

Mirror frame
half XVIII C. Louis XV French
Specchiera
metà XVIII Sec. Luigi XV Francese



Decoro
A039 Oro Versailles

DIMENSIONS / DIMENSIONI		
150 x h 265 cm		
MIRROR FINISHES / VARIANTI SPECCHIO		
PLAIN MIRROR / SPECCHIO LISCIO	BEVELLED MIRROR / MOLATO	ANTIQUÉ EFFECT MIRROR / ANTICATO
✓	-	✓

1052G

Half XVIII C. Robert Adam English



Art. 1052G
(photo ref. / foto ref.)

Mirror 3 panels 2nd
half XVIII C. Robert Adam English
Specchiera 3 pannelli 2°
metà XVIII Sec. Robert Adam Inglese



Decoro
G105 Argento Leggero

DIMENSIONS / DIMENSIONI		
128 x h 185 cm		
MIRROR FINISHES / VARIANTI SPECCHIO		
PLAIN MIRROR / SPECCHIO LISCIO	BEVELLED MIRROR / MOLATO	ANTIQUÉ EFFECT MIRROR / ANTICATO
✓	-	✓

1007S

End XVIII C. Neoclassical Italian



Art. 1007S
(photo ref. / foto ref.)

Mirror frame with flowers
end XVIII C. Neoclassical Italian
Specchiera con angoli a fiori
fine XVIII Sec. Neoclassico Italiano



Decoro
G006 Provence

DIMENSIONS / DIMENSIONI		
120 x h 240 cm		
MIRROR FINISHES / VARIANTI SPECCHIO		
PLAIN MIRROR / SPECCHIO LISCIO	BEVELLED MIRROR / MOLATO	ANTIQUÉ EFFECT MIRROR / ANTICATO
✓	-	✓

1300

Half XVII C. Louis XIV Italian



Art. 1300
(photo ref. / foto ref.)

Specchiera
metà XVII Sec. Luigi XIV Italiano
Mirror frame
half XVII C. Louis XIV Italian

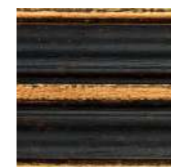

Decoro
G042 Ebony e Oro

DIMENSIONS / DIMENSIONI		
137 x h 200 cm		
MIRROR FINISHES / VARIANTI SPECCHIO		
PLAIN MIRROR / SPECCHIO LISCIO	BEVELLED MIRROR / MOLATO	ANTIQUÉ EFFECT MIRROR / ANTICATO
✓	-	✓

1295

Half XVIII C. Florentine



Art. 1295
(photo ref. / foto ref.)

Mirror frame
half XVIII C. Florentine
Specchiera
metà XVIII Sec. Fiorentino



Decoro
G072 Greige e oro

DIMENSIONS / DIMENSIONI		
101 x h 200 cm		
MIRROR FINISHES / VARIANTI SPECCHIO		
PLAIN DIVIDED MIRROR / SPECCHIO LISCIO DIVISO	BEVELLED MIRROR / MOLATO	ANTIQUÉ EFFECT DIVIDED MIRROR / ANTICATO DIVISO
✓	-	✓

1112

End XVIII C. Neoclassical Italian



Art. 1112
(photo ref. / foto ref.)

Mirror frame
end XVIII C. Neoclassical Italian
Specchiera
fine XVIII Sec. Neoclassico Italiano

Decoro
GS2259 Grigio e Bianco

DIMENSIONS / DIMENSIONI		
97 x h 210 cm		
MIRROR FINISHES / VARIANTI SPECCHIO		
PLAIN MIRROR / SPECCHIO LISCIO	BEVELLED MIRROR / MOLATO	ANTIQUÉ EFFECT MIRROR / ANTICATO
✓	-	✓

522

Half XVIII C. Chippendale English



Art. 522
(photo ref. / foto ref.)

Mirror frame with divided mirrors
half XVIII C. Chippendale English
Specchiera con specchi divisi
metà XVIII Sec. Chippendale Inglese



Decoro
G038 Oro Pitti

DIMENSIONS / DIMENSIONI		
93 x h 182 cm		
MIRROR FINISHES / VARIANTI SPECCHIO		
PLAIN MIRROR / SPECCHIO LISCIO	BEVELLED MIRROR / MOLATO	ANTIQUÉ EFFECT MIRROR / ANTICATO
✓	✓	✓

830

Half XVIII C. Venetian



Art. 830
(photo ref. / foto ref.)

Mirror frame
half XVIII C. Venetian
Specchiera
metà XVIII Sec. Veneziano



Decoro
G038 Oro Pitti

DIMENSIONS / DIMENSIONI		
91 x h 148 cm		
MIRROR FINISHES / VARIANTI SPECCHIO		
PLAIN MIRROR / SPECCHIO LISCIO	BEVELLED MIRROR / MOLATO	ANTIQUÉ EFFECT MIRROR / ANTICATO
✓	✓	✓

1253

Half XVII C. Baroque Florentine



Art. 1253
(photo ref. / foto ref.)

Mirror frame
half XVII C. Baroque Florentine
Specchiera
metà XVII Sec. Barocco Fiorentino



Decoro
G022 Argento Pitti

DIMENSIONS / DIMENSIONI		
120 x h 147 cm		
MIRROR FINISHES / VARIANTI SPECCHIO		
PLAIN MIRROR / SPECCHIO LISCIO	BEVELLED MIRROR / MOLATO	ANTIQUÉ EFFECT MIRROR / ANTICATO
✓	✓	✓

765

Half XVIII C. Chippendale English



Art. 765
(photo ref. / foto ref.)

Mirror frame
half XVIII C. Chippendale English
Specchiera
metà XVIII Sec. Chippendale Inglese



Decoro
G035 Oro Decapè Antico

DIMENSIONS / DIMENSIONI		
101 x h 144 cm		
MIRROR FINISHES / VARIANTI SPECCHIO		
PLAIN MIRROR / SPECCHIO LISCIO	BEVELLED MIRROR / MOLATO	ANTIQUÉ EFFECT MIRROR / ANTICATO
✓	-	✓

282

Half XVIII C. Louis XV French



282PV



282

Art. 282
(photo ref. / foto ref.)

Mirror frame
half XVIII C. Louis XV French
Specchiera
metà XVIII Sec. Luigi XV Francese

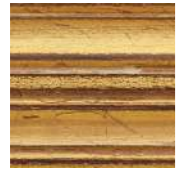

Decoro
G081 Oro Antiquariato

DIMENSIONS / DIMENSIONI		
100 x h 158 cm		
MIRROR FINISHES / VARIANTI SPECCHIO		
PLAIN MIRROR / SPECCHIO LISCIO	BEVELLED MIRROR / MOLATO	ANTIQUE EFFECT MIRROR / ANTICATO
✓	✓	✓
COLOURED GLASS INSERT OPTIONS / VARIANTE CON FASCE VETRO COLORATO		
282PV		

282G

Half XVIII C. Louis XV French



Art. 282G
(photo ref. / foto ref.)

Mirror frame
half XVIII C. Louis XV French
Specchiera
metà XVIII Sec. Luigi XV Francese

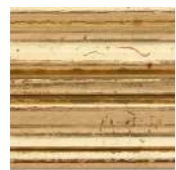

Decoro
A039 Oro Versailles

DIMENSIONS / DIMENSIONI		
150 x h 170 cm		
MIRROR FINISHES / VARIANTI SPECCHIO		
PLAIN MIRROR / SPECCHIO LISCIO	BEVELLED MIRROR / MOLATO	ANTIQUE EFFECT MIRROR / ANTICATO
✓	✓	✓
COLOURED GLASS INSERT OPTIONS / VARIANTE CON FASCE VETRO COLORATO		
282GPV		



Mirror frames_Specchiera

834

Half XVIII C. Venetian



Art. 834
(photo ref. / foto ref.)

Mirror frame
half XVIII C. Venetian
Specchiera
metà XVIII Sec. Veneziano

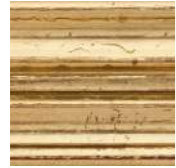

Decoro
A039 Oro Versailles

DIMENSIONS / DIMENSIONI		
110 x h 187 cm		
MIRROR FINISHES / VARIANTI SPECCHIO		
PLAIN MIRROR / SPECCHIO LISCIO	BEVELLED MIRROR / MOLATO	ANTIQUÉ EFFECT MIRROR / ANTICATO
✓	-	✓

1029

XVIII C. Piedmontese



Art. 1029
(photo ref. / foto ref.)

Mirror frame with garland
XVIII C. Piedmontese
Specchiera con ghirlanda
XVIII Sec. Piemontese

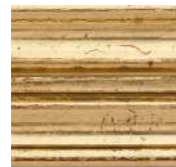

Decoro
G039 Oro Versailles

DIMENSIONS / DIMENSIONI		
108 x h 172 cm		
MIRROR FINISHES / VARIANTI SPECCHIO		
PLAIN MIRROR / SPECCHIO LISCIO	BEVELLED MIRROR / MOLATO	ANTIQUÉ EFFECT MIRROR / ANTICATO
✓	✓	✓
COLOURED GLASS INSERT OPTIONS / VARIANTE CON FASCE VETRO COLORATO		
1029PV		

1029PV

XVIII C. Piedmontese



1037

Half XVIII C. George II English



1037PV

1037

Art. 1037
(photo ref. / foto ref.)

Mirror frame
half XVIII C. George II English
Specchiera
metà XVIII Sec. Giorgio II Inglese

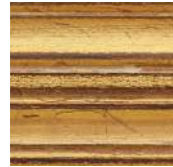

Decoro
G038 Oro Pitti

DIMENSIONS / DIMENSIONI		
87 x h 145 cm		
MIRROR FINISHES / VARIANTI SPECCHIO		
PLAIN MIRROR / SPECCHIO LISCIO	BEVELLED MIRROR / MOLATO	ANTIQUÉ EFFECT MIRROR / ANTICATO
✓	✓	✓
COLOURED GLASS INSERT OPTIONS / VARIANTE CON FASCE VETRO COLORATO		
1037PV		

890

Beg. XVIII C. Venetian



Art. 890
(photo ref. / foto ref.)

Mirror frame
beg. XVIII C. Venetian
Specchiera
inizio XVIII Sec. Veneziano



Decoro
A071 Argento e Oro

DIMENSIONS / DIMENSIONI		
102 x h 145 cm		
MIRROR FINISHES / VARIANTI SPECCHIO		
PLAIN MIRROR / SPECCHIO LISCIO	BEVELLED MIRROR / MOLATO	ANTIQUÉ EFFECT MIRROR / ANTICATO
✓	-	✓

778

Half XVII C. Louis XIV Italian



Art. 778
(photo ref. / foto ref.)

Mirror frame
half XVII C. Louis XIV Italian
Specchiera
metà XVII Sec. Luigi XIV Italiano



Decoro
G043 Ebony

DIMENSIONS / DIMENSIONI		
80 x h 97 cm		
MIRROR FINISHES / VARIANTI SPECCHIO		
PLAIN MIRROR / SPECCHIO LISCIO	BEVELLED MIRROR / MOLATO	ANTIQUÉ EFFECT MIRROR / ANTICATO
✓	✓	✓

1011

XVII C. Tuscan



Art. 1011
(photo ref. / foto ref.)

Mirror frame
XVII C. Tuscan
Specchiera
XVII Sec. Toscano



Decoro
G038 Oro Pitti

DIMENSIONS / DIMENSIONI		
89 x h 108 cm		
MIRROR FINISHES / VARIANTI SPECCHIO		
PLAIN MIRROR / SPECCHIO LISCIO	BEVELLED MIRROR / MOLATO	ANTIQUÉ EFFECT MIRROR / ANTICATO
✓	✓	✓

394

Half XVIII C. Louis XV French



Art. 394
(photo ref. / foto ref.)

Mirror frame
half XVIII C. Louis XV French
Specchiera
metà XVIII Sec. Luigi XV Francese



Decoro
G012 Greige

DIMENSIONS / DIMENSIONI		
83 x h 123 cm		
MIRROR FINISHES / VARIANTI SPECCHIO		
PLAIN MIRROR / SPECCHIO LISCIO	BEVELLED MIRROR / MOLATO	ANTIQUÉ EFFECT MIRROR / ANTICATO
✓	✓	✓

854

End XVII C. Tuscan



Art. 854
(photo ref. / foto ref.)

Mirror frame
end XVII C. Tuscan
Specchiera
fine XVII Sec. Toscano

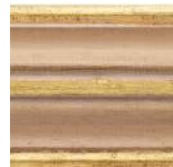

Decoro
G032 Pickled Pine e Oro

DIMENSIONS / DIMENSIONI		
85 x h 116 cm		
MIRROR FINISHES / VARIANTI SPECCHIO		
PLAIN MIRROR / SPECCHIO LISCIO	BEVELLED MIRROR / MOLATO	ANTIQUÉ EFFECT MIRROR / ANTICATO
✓	-	✓

824

Beg. XVIII C. Genoese



Art. 824
(photo ref. / foto ref.)

Mirror frame
beg. XVIII C. Genoese
Specchiera
inizio XVIII Sec. Genovese



Decoro
A029 Bolo e Oro

DIMENSIONS / DIMENSIONI		
78 x h 122 cm		
MIRROR FINISHES / VARIANTI SPECCHIO		
PLAIN MIRROR / SPECCHIO LISCIO	BEVELLED MIRROR / MOLATO	ANTIQUÉ EFFECT MIRROR / ANTICATO
✓	-	✓

1310

XVIII C. Venetian



Art. 1310
(photo ref. / foto ref.)

Mirror frame
XVIII C. Venetian
Specchiera
XVIII Sec. Veneziano



Decoro
G022 Argento Pitti

DIMENSIONS / DIMENSIONI		
100 x h 132 cm		
MIRROR FINISHES / VARIANTI SPECCHIO		
PLAIN MIRROR / SPECCHIO LISCIO	BEVELLED MIRROR / MOLATO	ANTIQUÉ EFFECT MIRROR / ANTICATO
✓	✓	✓

1052

Half XVIII C. Robert Adam English



Art. 1052
(photo ref. / foto ref.)

Mirror 3 panels 2nd half XVIII C. Robert Adam English
Specchiera 3 pannelli 2° metà XVIII Sec. Robert Adam Inglese

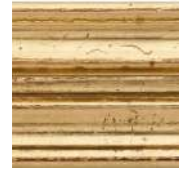

Decoro A039 Oro Versailles

ARTICLE / ARTICOLO		DIMENSIONS / DIMENSIONI
1052		128 x h 117 cm
1052S		128 x h 142 cm
MIRROR FINISHES / VARIANTI SPECCHIO		
PLAIN MIRROR / SPECCHIO LISCIO	BEVELLED MIRROR / MOLATO	ANTIQUÉ EFFECT MIRROR / ANTICATO
✓	-	✓

1113

Half XVIII C. Robert Adam English



Art. 1113
(photo ref. / foto ref.)

Mirror frame 2nd half XVIII C. Robert Adam English
Specchiera 2° metà XVIII Sec. Robert Adam Inglese



Decoro A039 Oro Versailles

ARTICLE / ARTICOLO		DIMENSIONS / DIMENSIONI
1113		89 x h 151 cm
1113S		89 x h 170 cm
MIRROR FINISHES / VARIANTI SPECCHIO		
PLAIN MIRROR / SPECCHIO LISCIO	BEVELLED MIRROR / MOLATO	ANTIQUÉ EFFECT MIRROR / ANTICATO
✓	✓	✓

877

End XVIII C. French

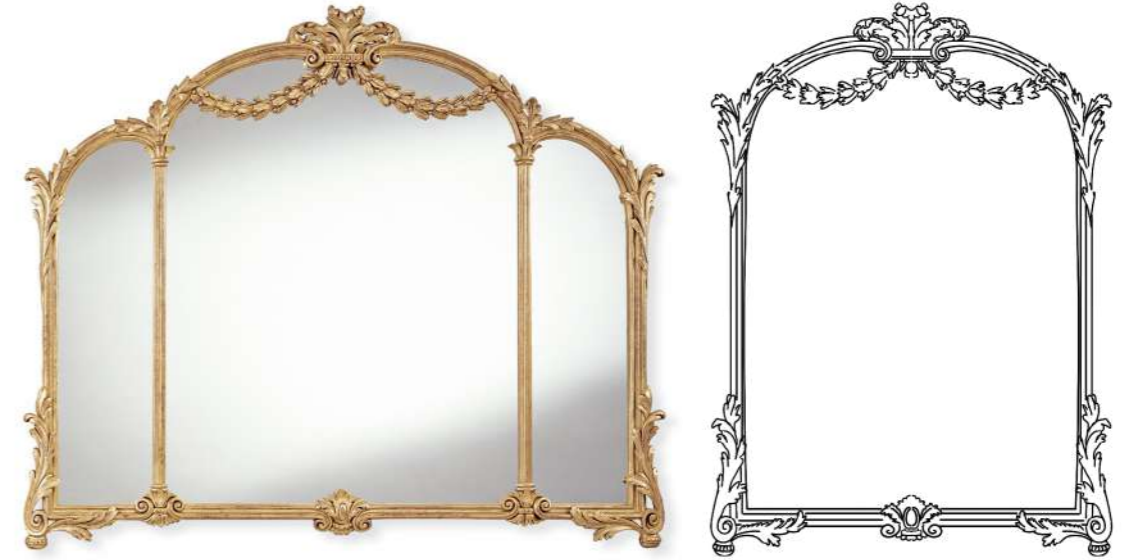

Art. 877
(photo ref. / foto ref.)

Mirror frame end XVIII C. French
Specchiera fine XVIII Sec. Francese

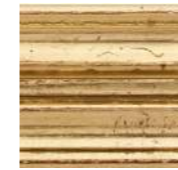

Decoro A039 Oro Versailles

ARTICLE / ARTICOLO		DIMENSIONS / DIMENSIONI
877		151 x h 130 cm
877S		93 x h 130 cm
MIRROR FINISHES / VARIANTI SPECCHIO		
PLAIN MIRROR / SPECCHIO LISCIO	BEVELLED MIRROR / MOLATO	ANTIQUÉ EFFECT MIRROR / ANTICATO
✓	-	✓

473

End XVIII C. Louis XVI French



Art. 473T
(photo ref. / foto ref.)

Mirror frame with garland of flowers end XVIII C. Louis XVI French
Specchiera con ghirlanda di fiori fine XVIII Sec. Luigi XVI Francese



Decoro A039 Oro Versailles

ARTICLE / ARTICOLO		DIMENSIONS / DIMENSIONI
473		72 x h 106 cm
473T		92 x h 86 cm
MIRROR FINISHES / VARIANTI SPECCHIO		
PLAIN MIRROR / SPECCHIO LISCIO	BEVELLED MIRROR / MOLATO	ANTIQUÉ EFFECT MIRROR / ANTICATO
✓	✓	✓

474

End XVIII C. Louis XVI French



Art. 474
(photo ref. / foto ref.)

Mirror with garland of flowers
end XVIII C. Louis XVI French
Specchiera con ghirlanda di fiori ad arco
fine XVIII Sec. Luigi XVI Francese



Decoro G061 Ciliegio e Oro

DIMENSIONS / DIMENSIONI		
72 x h 116 cm		
MIRROR FINISHES / VARIANTI SPECCHIO		
PLAIN MIRROR / SPECCHIO LISCIO	BEVELLED MIRROR / MOLATO	ANTIQUÉ EFFECT MIRROR / ANTICATO
✓	✓	✓

1210

Half XVIII C. Louis XV French



Art. 1210
(photo ref. / foto ref.)

Mirror frame
half XVIII C. Louis XV French
Specchiera metà XVIII Sec. Luigi XV Francese

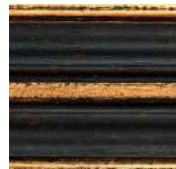

Decoro G042 Ebony e Oro

DIMENSIONS / DIMENSIONI		
92 x h 132 cm		
MIRROR FINISHES / VARIANTI SPECCHIO		
PLAIN MIRROR / SPECCHIO LISCIO	BEVELLED MIRROR / MOLATO	ANTIQUÉ EFFECT MIRROR / ANTICATO
✓	-	✓

488

End XVIII C. Neoclassical Italian



Art. 488
(photo ref. / foto ref.)

Mirror frame with olives ramage
end XVIII C. Neoclassical Italian
Specchiera con rami d'olivo
fine XVIII Sec. Neoclassico Italiano



Decoro G010 Florence

DIMENSIONS / DIMENSIONI		
76 x h 135 cm		
MIRROR FINISHES / VARIANTI SPECCHIO		
PLAIN MIRROR / SPECCHIO LISCIO	BEVELLED MIRROR / MOLATO	ANTIQUÉ EFFECT MIRROR / ANTICATO
✓	✓	✓

1276

Half XVIII C. Venetian



Art. 1276
(photo ref. / foto ref.)

Mirror frame
half XVIII C. Venetian
Specchiera metà XVIII Sec. Veneziano



Decoro G038 Oro Pitti

DIMENSIONS / DIMENSIONI		
119 x h 105 cm		
MIRROR FINISHES / VARIANTI SPECCHIO		
PLAIN MIRROR / SPECCHIO LISCIO	BEVELLED MIRROR / MOLATO	ANTIQUÉ EFFECT MIRROR / ANTICATO
✓	-	✓

1256

Half XVIII C. Louis XV French



Art. 1256
(photo ref. / foto ref.)

Mirror frame
half XVIII C. Louis XV French
Specchiera
metà XVIII Sec. Luigi XV Francese

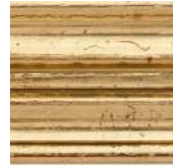

Decoro
G039 Oro Versailles

DIMENSIONS / DIMENSIONI		
125 x h 95 cm		
MIRROR FINISHES / VARIANTI SPECCHIO		
PLAIN MIRROR / SPECCHIO LISCIO	BEVELLED MIRROR / MOLATO	ANTIQUÉ EFFECT MIRROR / ANTICATO
✓	-	✓

523

Half XVIII C. Chippendale English



Art. 523
(photo ref. / foto ref.)

Mirror frame
half XVIII C. Chippendale English
Specchiera
metà XVIII Sec. Chippendale Inglese



Decoro
G008 Trianon

DIMENSIONS / DIMENSIONI		
134 x h 101 cm		
MIRROR FINISHES / VARIANTI SPECCHIO		
PLAIN MIRROR / SPECCHIO LISCIO	BEVELLED MIRROR / MOLATO	ANTIQUÉ EFFECT MIRROR / ANTICATO
✓	-	✓

1147

Half XVIII C. Louis XV Italian



Art. 1147
(photo ref. / foto ref.)

Horizontal mirror frame
half XVIII C. Louis XV Italian
Specchiera orizzontale
metà XVIII Sec. Luigi XV Italiano



Decoro
A039 Oro Versailles

DIMENSIONS / DIMENSIONI		
147 x h 113 cm		
MIRROR FINISHES / VARIANTI SPECCHIO		
PLAIN MIRROR / SPECCHIO LISCIO	BEVELLED MIRROR / MOLATO	ANTIQUÉ EFFECT MIRROR / ANTICATO
✓	-	✓

1120

Half XVIII C. Neapolitan



Art. 1120
(photo ref. / foto ref.)

Mirror frame
half XVIII C. Neapolitan
Specchiera
metà XVIII Sec. Napoletano



Decoro
G038 Oro Pitti

DIMENSIONS / DIMENSIONI		
108 x h 93 cm		
MIRROR FINISHES / VARIANTI SPECCHIO		
PLAIN MIRROR / SPECCHIO LISCIO	BEVELLED MIRROR / MOLATO	ANTIQUÉ EFFECT MIRROR / ANTICATO
✓	-	✓

934

Half XVII C. Louis XIV Italian



Art. 934
(photo ref. / foto ref.)

Mirror frame
half XVII C. Louis XIV Italian
Specchiera
metà XVII Sec. Luigi XIV Italiano



Decoro
A023 Argento

ARTICLE / ARTICOLO		DIMENSIONS / DIMENSIONI
934		77 x h 104 cm
934GG		124 x h 178 cm
MIRROR FINISHES / VARIANTI SPECCHIO		
PLAIN MIRROR / SPECCHIO LISCIO	BEVELLED MIRROR / MOLATO	ANTIQUÉ EFFECT MIRROR / ANTICATO
✓	-	✓

840

Half XVIII C. Genoese



Art. 840
(photo ref. / foto ref.)

Mirror frame
half XVIII C. Genoese
Specchiera
metà XVIII Sec. Genovese



Decoro
G038 Oro Pitti

DIMENSIONS / DIMENSIONI		
80 x h 119 cm		
MIRROR FINISHES / VARIANTI SPECCHIO		
PLAIN MIRROR / SPECCHIO LISCIO	BEVELLED MIRROR / MOLATO	ANTIQUÉ EFFECT MIRROR / ANTICATO
✓	-	✓

812G

End XVIII C. Venetian



Art. 812G
(photo ref. / foto ref.)

Mirror frame
end XVIII C. Venetian
Specchiera
fine XVIII Sec. Veneziano

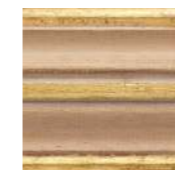

Decoro
G032 Pickled Pine Oro

DIMENSIONS / DIMENSIONI		
70 x h 110 cm		
MIRROR FINISHES / VARIANTI SPECCHIO		
PLAIN MIRROR / SPECCHIO LISCIO	BEVELLED MIRROR / MOLATO	ANTIQUÉ EFFECT MIRROR / ANTICATO
✓	-	✓

492

Beg. XIX C. Neoclassical Italian



Art. 492
(photo ref. / foto ref.)

Mirror frame oval with ribbon
beg. XIX C. Neoclassical Italian
Specchiera ovale fiocco a nastro
inizio XIX Sec. Neoclassico Italiano



Decoro
A033 Oro Soleil Decapè

DIMENSIONS / DIMENSIONI		
69 x h 107 cm		
MIRROR FINISHES / VARIANTI SPECCHIO		
PLAIN MIRROR / SPECCHIO LISCIO	BEVELLED MIRROR / MOLATO	ANTIQUÉ EFFECT MIRROR / ANTICATO
✓	✓	✓

1167

Half XVIII C. Robert Adam English



Art. 1167
(photo ref. / foto ref.)

Oval mirror frame 2nd half XVIII C. Robert Adam English
Specchiera ovale 2° metà XVIII Sec. Robert Adam Inglese

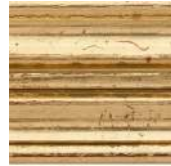

Decoro
A039 Oro Versailles

DIMENSIONS / DIMENSIONI		
71 x h 134 cm		
MIRROR FINISHES / VARIANTI SPECCHIO		
PLAIN MIRROR / SPECCHIO LISCIO	BEVELLED MIRROR / MOLATO	ANTIQUÉ EFFECT MIRROR / ANTICATO
✓	✓	✓

750

Half XVII C. Louis XIV French



Art. 750
(photo ref. / foto ref.)

Mirror frame half XVII C. Louis XIV French
Specchiera metà XVII Sec. Luigi XIV Francese



Decoro
G038 Oro Pitti

DIMENSIONS / DIMENSIONI		
80 x h 130 cm		
MIRROR FINISHES / VARIANTI SPECCHIO		
PLAIN MIRROR / SPECCHIO LISCIO	BEVELLED MIRROR / MOLATO	ANTIQUÉ EFFECT MIRROR / ANTICATO
✓	-	✓

524

2nd half XVIII C. Robert Adam English



Art. 524
(photo ref. / foto ref.)

Oval mirror frame 2nd half XVIII C. Robert Adam English
Specchiera ovale 2° metà XVIII Sec. Robert Adam Inglese



Decoro
G061 Ciliegio e Oro

DIMENSIONS / DIMENSIONI		
73 x h 134 cm		
MIRROR FINISHES / VARIANTI SPECCHIO		
PLAIN MIRROR / SPECCHIO LISCIO	BEVELLED MIRROR / MOLATO	ANTIQUÉ EFFECT MIRROR / ANTICATO
✓	✓	✓

367

Half XVIII C. Chippendale English



Art. 367
(photo ref. / foto ref.)

Mirror frame half XVIII C. Chippendale English
Specchiera metà XVIII Sec. Chippendale Inglese



Decoro
A024 Argento Luce

DIMENSIONS / DIMENSIONI		
75 x h 135 cm		
MIRROR FINISHES / VARIANTI SPECCHIO		
PLAIN MIRROR / SPECCHIO LISCIO	BEVELLED MIRROR / MOLATO	ANTIQUÉ EFFECT MIRROR / ANTICATO
✓	✓	✓

1131

Half XVII C. Louis XIV Italian



Art. 1131
(photo ref. / foto ref.)

Oval mirror frame
half XVII C. Louis XIV Italian
Specchiera ovale
metà XVII Sec. Luigi XIV Italiano



Decoro
A030 Castagna e Oro

DIMENSIONS / DIMENSIONI		
152 x h 126 cm		
MIRROR FINISHES / VARIANTI SPECCHIO		
PLAIN MIRROR / SPECCHIO LISCIO	BEVELLED MIRROR / MOLATO	ANTIQUÉ EFFECT MIRROR / ANTICATO
✓	✓	✓

1366SPV

End XVIII C. Neoclassical Italian



Art. 1366SPV
(photo ref. / foto ref.)

Round mirror frame with laurel leaves
and colored glass passepartout
end XVIII C. Neoclassical Italian
Specchiera tonda con foglie di lauro
e passepartout in vetro colorato
fine XVIII Sec. Neoclassico Italiano



Decoro
G038 Oro Pitti

DIMENSIONS / DIMENSIONI		
Ø121 cm		
MIRROR FINISHES / VARIANTI SPECCHIO		
PLAIN MIRROR / SPECCHIO LISCIO	BEVELLED MIRROR / MOLATO	ANTIQUÉ EFFECT MIRROR / ANTICATO
✓	✓	✓
COLOURED GLASS OR SEMI PRECIOUS PASSEPARTOUT / PASSEPARTOUT CON VETRO COLORATO O PIETRA SEMIPREZIOSA		
1366PV		

1132T

End XVIII C. Louis XVI French



Art. 1132T
(photo ref. / foto ref.)

Horizontal oval mirror frame
end XVIII C. Louis XVI French
Specchiera ovale orizzontale
fine XVIII Sec. Luigi XVI Francese



Decoro
A039 Oro Versailles

DIMENSIONS / DIMENSIONI		
103 x h 80 cm		
MIRROR FINISHES / VARIANTI SPECCHIO		
PLAIN MIRROR / SPECCHIO LISCIO	BEVELLED MIRROR / MOLATO	ANTIQUÉ EFFECT MIRROR / ANTICATO
✓	✓	✓

1132

End XVIII C. Louis XVI French



Art. 1132
(photo ref. / foto ref.)

Oval mirror frame
end XVIII C. Louis XVI French
Specchiera ovale
fine XVIII Sec. Luigi XVI Francese



Decoro
A039 Oro Versailles

DIMENSIONS / DIMENSIONI		
70 x h 98 cm		
MIRROR FINISHES / VARIANTI SPECCHIO		
PLAIN MIRROR / SPECCHIO LISCIO	BEVELLED MIRROR / MOLATO	ANTIQUÉ EFFECT MIRROR / ANTICATO
✓	✓	✓

179

End XVIII C. Venetian



Art. 179
(photo ref. / foto ref.)

Mirror with glass or mirror insert
in the frame
end XVIII C. Venetian
Specchiera con inserti in vetro
o specchio
fine XVIII Sec. Veneziano



Decoro
G086 Noir

DIMENSIONS / DIMENSIONI		
90 x h 90 cm		
MIRROR FINISHES / VARIANTI SPECCHIO		
PLAIN MIRROR / SPECCHIO LISCIO	BEVELLED MIRROR / MOLATO	ANTIQUE EFFECT MIRROR / ANTICATO
✓	✓	✓



1013G

End XVIII C. Neoclassical Italian



Art. 1013G
(photo ref. / foto ref.)

Mirror frame with roses
end XVIII C. Neoclassical Italian
Specchiera con roselline
fine XVIII Sec. Neoclassico Italiano



Decoro
A036 Oro Antico

DIMENSIONS / DIMENSIONI		
107 x h 147 cm		
MIRROR FINISHES / VARIANTI SPECCHIO		
PLAIN MIRROR / SPECCHIO LISCIO	BEVELLED MIRROR / MOLATO	ANTIQUÉ EFFECT MIRROR / ANTICATO
✓	✓	✓

1114

XVII C. Flemish



Art. 1114
(photo ref. / foto ref.)

Mirror frame
XVII C. Flemish
Specchiera
XVII Sec. Fiammingo



Decoro
G042 Ebony e Oro

DIMENSIONS / DIMENSIONI		
120 x h 162 cm		
MIRROR FINISHES / VARIANTI SPECCHIO		
PLAIN MIRROR / SPECCHIO LISCIO	BEVELLED MIRROR / MOLATO	ANTIQUÉ EFFECT MIRROR / ANTICATO
✓	✓	✓

550

End XVIII C. Louis XVI French



Art. 550
(photo ref. / foto ref.)

Specchiera foglie quercia
fine XVIII Sec. Luigi XVI Francese
Mirror frame oak leaves
end XVIII C. Louis XVI French

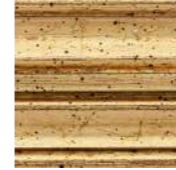

Decoro
A036 Oro Antico

ARTICLE / ARTICOLO	DIMENSIONS / DIMENSIONI	
550	98 x h 135 cm	
550G	110 x h 165 cm	
MIRROR FINISHES / VARIANTI SPECCHIO		
PLAIN MIRROR / SPECCHIO LISCIO	BEVELLED MIRROR / MOLATO	ANTIQUÉ EFFECT MIRROR / ANTICATO
✓	✓	✓
CUSTOMIZED OPTION COLOURED GLASS INSERTS / VARIANTE CON FASCE VETRO COLORATO		
550GPV		

550T

End XVIII C. Louis XVI French



Art. 550T
(photo ref. / foto ref.)

Mirror frame oak leaves
end XVIII C. Louis XVI French
Specchiera foglie quercia
fine XVIII Sec. Luigi XVI Francese



Decoro
G039 Oro Versailles

DIMENSIONS / DIMENSIONI		
127 x h 109 cm		
MIRROR FINISHES / VARIANTI SPECCHIO		
PLAIN MIRROR / SPECCHIO LISCIO	BEVELLED MIRROR / MOLATO	ANTIQUÉ EFFECT MIRROR / ANTICATO
✓	✓	✓



842

Beg. XVIII C. Regency French

Art. 842SPV
(photo ref. / foto ref.)

Mirror frame
beg. XVIII C. Regency French
Specchiera inizio
XVIII Sec. Reggenza Francese



Decoro
G081 Oro Antiquariato

843

Beg. XVIII C. Regency French

Art. 843
(photo ref. / foto ref.)

Mirror frame
beg. XVIII C. Regency French
Specchiera inizio
XVIII Sec. Reggenza Francese



Decoro
G038 Oro Pitti



842SPV



842S

DIMENSIONS / DIMENSIONI		
105 x h 130 cm		
MIRROR FINISHES / VARIANTI SPECCHIO		
PLAIN MIRROR / SPECCHIO LISCIO	BEVELLED MIRROR / MOLATO	ANTIQUÉ EFFECT MIRROR / ANTICATO
✓	✓	✓
COLOURED GLASS INSERTS / VARIANTE CON FASCE VETRO COLORATO		
842SPV		



842SPV



843

DIMENSIONS / DIMENSIONI		
85 x h 104 cm		
MIRROR FINISHES / VARIANTI SPECCHIO		
PLAIN MIRROR / SPECCHIO LISCIO	BEVELLED MIRROR / MOLATO	ANTIQUÉ EFFECT MIRROR / ANTICATO
✓	✓	✓
COLOURED GLASS INSERTS / VARIANTE CON FASCE VETRO COLORATO		
843PV		

1001GS
End XVII C. Tuscan



Art. 1001GS
(photo ref. / foto ref.)

Mirror frame scroll carved leaves with onyx passe-partout end XVII C. Tuscan
Specchiera con foglie a cartoccio e passepartout in onice fine XVII Sec. Toscano



Decoro
A077 Oro Francese

DIMENSIONS / DIMENSIONI		
110 x h 160 cm		
MIRROR FINISHES / VARIANTI SPECCHIO		
PLAIN MIRROR / SPECCHIO LISCIO	BEVELLED MIRROR / MOLATO	ANTIQUÉ EFFECT MIRROR / ANTICATO
✓	✓	✓



1001

End XVII C. Tuscan



Art. 1001
(photo ref. / foto ref.)

Mirror frame scroll carved leaves
end XVII C. Tuscan
Specchiera con foglie a cartoccio
fine XVII Sec. Toscano



Decoro
G022 Argento Pitti

ARTICLE / ARTICOLO		DIMENSIONS / DIMENSIONI	
1001		94 x h 126 cm	
1001G		110 x h 160 cm	
MIRROR FINISHES / VARIANTI SPECCHIO			
PLAIN MIRROR / SPECCHIO LISCIO	BEVELLED MIRROR / MOLATO	ANTIQUE EFFECT MIRROR / ANTICATO	
✓	✓	✓	

1007

End XVIII C. Neoclassical Italian



Art. 1007
(photo ref. / foto ref.)

Mirror frame with flowers
end XVIII C. Neoclassical Italian
Specchiera con angoli a fiori
fine XVIII Sec. Neoclassico Italiano



Decoro
G012 Greige

DIMENSIONS / DIMENSIONI		
112 x h 161 cm		
MIRROR FINISHES / VARIANTI SPECCHIO		
PLAIN MIRROR / SPECCHIO LISCIO	BEVELLED MIRROR / MOLATO	ANTIQUE EFFECT MIRROR / ANTICATO
✓	✓	✓

1240

End XVIII C. Neoclassical French



Art. 1240G
(photo ref. / foto ref.)

Mirror frame
end XVIII C. Neoclassical French
Specchiera
fine XVIII Sec. Neoclassico Francese

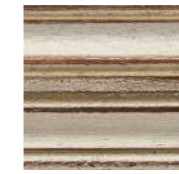

Decoro
G022 Argento Pitti

ARTICLE / ARTICOLO		DIMENSIONS / DIMENSIONI	
1240G		103 x h 172 cm	
1240M		103 x h 145 cm	
1240P		89 x h 116 cm	
MIRROR FINISHES / VARIANTI SPECCHIO			
PLAIN MIRROR / SPECCHIO LISCIO	BEVELLED MIRROR / MOLATO	ANTIQUE EFFECT MIRROR / ANTICATO	
✓	✓	✓	

668G

Half XVII C. Louis XIV Italian



Art. 668G
(photo ref. / foto ref.)

Mirror frame
half XVII C. Louis XIV Italian
Specchiera
metà XVII Sec. Luigi XIV Italiano



Decoro
G043 Ebony

DIMENSIONS / DIMENSIONI		
71 x h 106 cm		
MIRROR FINISHES / VARIANTI SPECCHIO		
PLAIN MIRROR / SPECCHIO LISCIO	BEVELLED MIRROR / MOLATO	ANTIQUE EFFECT MIRROR / ANTICATO
✓	✓	✓

682

2nd half XVII C. Florentine

Art. 682

(photo ref. / foto ref.)

Mirror frame with shell
2nd half XVII C. Florentine
Specchiera con conchiglia
2° metà XVII Sec. Fiorentino



Decoro
G006 Provence



ARTICLE / ARTICOLO		DIMENSIONS / DIMENSIONI	
682		90 x h 120 cm	
682G		110 x h 162 cm	
MIRROR FINISHES / VARIANTI SPECCHIO			
PLAIN MIRROR / SPECCHIO LISCIO	BEVELLED MIRROR / MOLATO	ANTIQUE EFFECT MIRROR / ANTICATO	
✓	✓	✓	

290G

End XVIII C. Venetian

Art. 290G

(photo ref. / foto ref.)

Mirror frame with mirrors
end XVIII C. Venetian
Specchiera con cornice a specchi
fine XVIII Sec. Veneziano



Decoro
G023 Argento



DIMENSIONS / DIMENSIONI		
103 x h 136 cm		
MIRROR FINISHES / VARIANTI SPECCHIO		
PLAIN MIRROR / SPECCHIO LISCIO	BEVELLED MIRROR / MOLATO	ANTIQUE EFFECT MIRROR / ANTICATO
✓	✓	✓

703

End XVIII C. Piedmontese

Art. 703

(photo ref. / foto ref.)

Mirror frame
end XVIII C. Piedmontese
Specchiera
fine XVIII Sec. Piemontese



Decoro
G061 Ciliegio e Oro



DIMENSIONS / DIMENSIONI		
84 x h 126 cm		
MIRROR FINISHES / VARIANTI SPECCHIO		
PLAIN MIRROR / SPECCHIO LISCIO	BEVELLED MIRROR / MOLATO	ANTIQUE EFFECT MIRROR / ANTICATO
✓	✓	✓

1332

XVIII C. French

Art. 1332

(photo ref. / foto ref.)

Mirror frame
XVIII C. French
Specchiera
XVIII Sec. Francese



Decoro
G038 Oro Pitti



DIMENSIONS / DIMENSIONI		
79 x h 122 cm		
MIRROR FINISHES / VARIANTI SPECCHIO		
PLAIN MIRROR / SPECCHIO LISCIO	BEVELLED MIRROR / MOLATO	ANTIQUE EFFECT MIRROR / ANTICATO
✓	-	✓

117L

End XVIII C. Tuscan



Art. 117L
(photo ref. / foto ref.)

Mirror frame with flowers
end XVIII C. Tuscan
Specchiera con fiori
fine XVIII Sec. Toscano

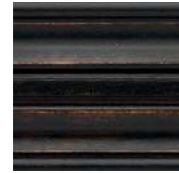

Decoro
G043 Ebony

ARTICLE / ARTICOLO	DIMENSIONS / DIMENSIONI
117L	39 x h 120 cm
117	39 x h 55 cm

MIRROR FINISHES / VARIANTI SPECCHIO		
PLAIN MIRROR / SPECCHIO LISCIO	BEVELLED MIRROR / MOLATO	ANTIQUÉ EFFECT MIRROR / ANTICATO
✓	✓	✓

1271G

XVIII C. Tuscan



Art. 1271G
(photo ref. / foto ref.)

Mirror frame
XVIII C. Tuscan
Specchiera
XVIII Sec. Toscano



Decoro
A023 Argento

ARTICLE / ARTICOLO	DIMENSIONS / DIMENSIONI
1271G	69 x h 161 cm
1271P	69 x h 121 cm

MIRROR FINISHES / VARIANTI SPECCHIO		
PLAIN MIRROR / SPECCHIO LISCIO	BEVELLED MIRROR / MOLATO	ANTIQUÉ EFFECT MIRROR / ANTICATO
✓	-	✓

486

End XVIII C. Louis XVI French



Art. 486
(photo ref. / foto ref.)

Mirror frame
end XVIII C. Louis XVI French
Specchiera
fine XVIII Sec. Luigi XVI Francese

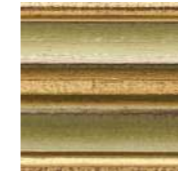

Decoro
G016 Muschio Oro

DIMENSIONS / DIMENSIONI		
43 x h 110 cm		

MIRROR FINISHES / VARIANTI SPECCHIO		
PLAIN MIRROR / SPECCHIO LISCIO	BEVELLED MIRROR / MOLATO	ANTIQUÉ EFFECT MIRROR / ANTICATO
✓	-	✓

451

End XVIII C. Louis XVI French



Art. 451
(photo ref. / foto ref.)

Mirror frame with ribbon carving
end XVIII C. Louis XVI French
Specchiera con fiocco
fine XVIII Sec. Luigi XVI Francese



Decoro
G010 Florence

ARTICLE / ARTICOLO	DIMENSIONS / DIMENSIONI
451	42 x h 105 cm
451S	70 x h 180 cm

MIRROR FINISHES / VARIANTI SPECCHIO		
PLAIN MIRROR / SPECCHIO LISCIO	BEVELLED MIRROR / MOLATO	ANTIQUÉ EFFECT MIRROR / ANTICATO
✓	✓	✓

1366

End XVIII C. Neoclassical Italian



Art. 1366
(photo ref. / foto ref.)

Round mirror frame with laurel leaves
end XVIII C. Neoclassical Italian
Specchiera tonda con foglie di lauro
fine XVIII Sec. Neoclassico Italiano



Decoro
G038 Oro Pitti

ARTICLE / ARTICOLO	DIMENSIONS / DIMENSIONI		
1366	Ø 121 cm		
1366P	Ø 59 cm		
MIRROR FINISHES / VARIANTI SPECCHIO			
PLAIN MIRROR / SPECCHIO LISCIO	BEVELLED MIRROR / MOLATO	ANTIQUE EFFECT MIRROR / ANTICATO	
✓	✓	✓	

356

End XVIII C. Neoclassical Italian



Art. 356
(photo ref. / foto ref.)

Round mirror frame with laurel leaves
end XVIII C. Neoclassical Italian
Specchiera tonda con foglie quercia
e passepartout in vetro colorato
fine XVIII Sec. Neoclassico Italiano



Decoro
G061 Ciliegio e Oro

ARTICLE / ARTICOLO	DIMENSIONS / DIMENSIONI		
356	Ø 106 cm		
356P	Ø 36 cm		
MIRROR FINISHES / VARIANTI SPECCHIO			
PLAIN MIRROR / SPECCHIO LISCIO	BEVELLED MIRROR / MOLATO	ANTIQUE EFFECT MIRROR / ANTICATO	
✓	✓	✓	

674

XVIII C. Italy



Art. 674
(photo ref. / foto ref.)

Mirror frame sun shape
XVIII C. Italy
Specchiera a sole
XVIII Sec. Italia

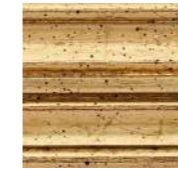

Decoro
A036 Oro Antico

ARTICLE / ARTICOLO	DIMENSIONS / DIMENSIONI		
674	Ø78 cm		
674G	Ø100 cm		
MIRROR FINISHES / VARIANTI SPECCHIO			
PLAIN MIRROR / SPECCHIO LISCIO	BEVELLED MIRROR / MOLATO	ANTIQUE EFFECT MIRROR / ANTICATO	
✓	✓	✓	

244

End XVIII C. English



Art. 244
(photo ref. / foto ref.)

Mirror frame with eagle
end XVIII C. English
Specchiera con aquila
fine XVIII Sec. Inglese

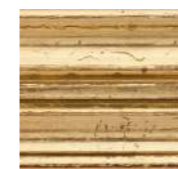

Decoro
A039 Oro Versailles

DIMENSIONS / DIMENSIONI		
53 x h 82 cm		
MIRROR FINISHES / VARIANTI SPECCHIO		
PLAIN MIRROR / SPECCHIO LISCIO	BEVELLED MIRROR / MOLATO	ANTIQUE EFFECT MIRROR / ANTICATO
✓	✓	✓

1152

2nd XVII C. Baroque Italian



Art. 1152
(photo ref. / foto ref.)

Oval mirror frame
2nd XVII C. Baroque Italian
Specchiera ovale
2° XVII Sec. Barocco Italiano



Decoro
G022 Argento Pitti

DIMENSIONS / DIMENSIONI		
54 x h 65 cm		
MIRROR FINISHES / VARIANTI SPECCHIO		
PLAIN MIRROR / SPECCHIO LISCIO	BEVELLED MIRROR / MOLATO	ANTIQUÉ EFFECT MIRROR / ANTICATO
✓	✓	✓

725

Half XVIII C. Roman



Art. 725
(photo ref. / foto ref.)

Oval mirror frame
half XVIII C. Roman
Specchiera ovale
metà XVIII Sec. Romano



Decoro
G012 Greige

DIMENSIONS / DIMENSIONI		
93 x h 103 cm		
MIRROR FINISHES / VARIANTI SPECCHIO		
PLAIN MIRROR / SPECCHIO LISCIO	BEVELLED MIRROR / MOLATO	ANTIQUÉ EFFECT MIRROR / ANTICATO
✓	✓	✓

413

Beg. XIX C. Empire French



Art. 413
(photo ref. / foto ref.)

Round mirror frame with laurel leaves
beg. XIX C. Empire French
Specchiera con foglie alloro
inizio XIX Sec. Impero Francese

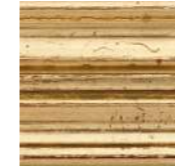

Decoro
A039 Oro Versailles

DIMENSIONS / DIMENSIONI		
Ø40 cm		
MIRROR FINISHES / VARIANTI SPECCHIO		
PLAIN MIRROR / SPECCHIO LISCIO	BEVELLED MIRROR / MOLATO	ANTIQUÉ EFFECT MIRROR / ANTICATO
✓	-	✓

970

Beg. XVIII C. Italian

Art. 970



Art. 970
(photo ref. / foto ref.)

Mirror frame
beg. XVIII C. Italian
Specchiera
inizio XVIII Sec. Italiano



Decoro
A066 Riace

DIMENSIONS / DIMENSIONI		
51 x h 53 cm		
MIRROR FINISHES / VARIANTI SPECCHIO		
PLAIN MIRROR / SPECCHIO LISCIO	BEVELLED / MOLATO	ANTIQUÉ / ANTICATO
✓	✓	✓



1323

XVIII C. Tuscan

Art. 1323

Art. 1323

(photo ref. / foto ref.)

Mirror frame with flowers
XVIII C. Tuscan
Specchiera vanity con fiori
XVIII Sec. Toscano



Decoro
G011 Vanwood

1327

XVIII C. Italian

Art. 1327

(photo ref. / foto ref.)

Vanity mirror
XVIII C. Italian
Specchiera vanity
XVIII Sec. Italiano



Decoro
G038 Oro Pitti



DIMENSIONS / DIMENSIONI

99 x h 73 cm

MIRROR FINISHES / VARIANTI SPECCHIO

PLAIN MIRROR / SPECCHIO LISCIO	BEVELLED MIRROR / MOLATO	ANTIQUÉ EFFECT MIRROR / ANTICATO
✓	-	✓



DIMENSIONS / DIMENSIONI

72 x 21 x h 69 cm

MIRROR FINISHES / VARIANTI SPECCHIO

PLAIN MIRROR / SPECCHIO LISCIO	BEVELLED MIRROR / MOLATO	ANTIQUÉ EFFECT MIRROR / ANTICATO
✓	-	✓

109

End XVIII C. Neoclassical French

Art. 109
(photo ref. / foto ref.)

Mirror frame with bow
end XVIII C. Neoclassical French
Specchiera con fiocco
fine XVIII Sec. Neoclassico Francese



DIMENSIONS / DIMENSIONI		
36 x h 52 cm		
MIRROR FINISHES / VARIANTI SPECCHIO		
PLAIN MIRROR / SPECCHIO LISCIO	BEVELLED MIRROR / MOLATO	ANTIQUÉ EFFECT MIRROR / ANTICATO
✓	✓	✓
PHOTOFRAME VERSION / VERSIONE PORTAFOTO		
109F		



Decoro
A023 Argento

118

Half XVIII C. Venetian Italy

Art. 118F
(photo ref. / foto ref.)

Photo frame
half XVIII C. Venetian Italy
Portafoto
metà XVIII Sec. Veneziano Italia



DIMENSIONS / DIMENSIONI		
37 x h 57 cm		
MIRROR FINISHES / VARIANTI SPECCHIO		
PLAIN MIRROR / SPECCHIO LISCIO	BEVELLED MIRROR / MOLATO	ANTIQUÉ EFFECT MIRROR / ANTICATO
✓	✓	✓
MIRROR FRAME / VARIANTE CORNICE PER SPECCHIO		
118		



Decoro
A023 Argento

1213

End XVIII C. Neoclassical Italian

Art. 1213
(photo ref. / foto ref.)

Mirror with shell
end XVIII C. Neoclassical Italian
Specchiera con conchiglia
fine XVIII Sec. Neoclassico Italiano



STA-PA Tuscan landscape print
Stampa paesaggio Toscano

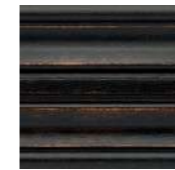

Decoro
G043 Ebony

DIMENSIONS / DIMENSIONI		
34 x h 52 cm		
MIRROR FINISHES / VARIANTI SPECCHIO		
PLAIN MIRROR / SPECCHIO LISCIO	BEVELLED MIRROR / MOLATO	ANTIQUÉ EFFECT MIRROR / ANTICATO
✓	-	✓

849

Beg. XVIII C. Tuscan

Art. 849A
(photo ref. / foto ref.)

Mirror frame
beg. XVIII C. Tuscan
Specchiera
inizio XVIII Sec. Toscano



DIS-PA4 A4 size print
with passe-partout
Disegno A4 con
passe-partout



Decoro
G038 Oro Pitti

ARTICLE / ARTICOLO	DIMENSIONS / DIMENSIONI	
849A	50 x h 60 cm	
849B	50 x h 70 cm	
849C	60 x h 80 cm	
849D	70 x h 90 cm	
849E	70 x h 100 cm	
MIRROR FINISHES / VARIANTI SPECCHIO		
PLAIN MIRROR / SPECCHIO LISCIO	BEVELLED MIRROR / MOLATO	ANTIQUÉ EFFECT MIRROR / ANTICATO
✓	✓	✓

634

Beg. XVIII C. Louis XIV French



Art. 634PF
(photo ref. / foto ref.)

Photo frame
beg. XVIII C. Louis XIV French
Portafoto
inizio XVIII Sec. Luigi XIV Francese



Decoro
G022 Argento Pitti

ARTICLE / ARTICOLO		DIMENSIONS / DIMENSIONI	
634PF		31 x h 47 cm	
634PO		40 x h 38 cm	
MIRROR FINISHES / VARIANTI SPECCHIO			
PLAIN MIRROR / SPECCHIO LISCIO	BEVELLED MIRROR / MOLATO	ANTIQUE EFFECT MIRROR / ANTICATO	
✓	✓	✓	
MIRROR FRAME / VARIANTE CORNICE PER SPECCHIO			
634P			

989

Half XVIII C. Louis XV French



Art. 989D
(photo ref. / foto ref.)

Mirror
half XVIII C. Louis XV French
Specchiera
metà XVIII Sec. Luigi XV Francese

DIS-A3 A3 size print
Disegno A3



Decoro
G043 Ebony

ARTICLE / ARTICOLO		DIMENSIONS / DIMENSIONI	
989D		70 x h 90 cm	
989E		70 x h 100 cm	
MIRROR FINISHES / VARIANTI SPECCHIO			
PLAIN MIRROR / SPECCHIO LISCIO	BEVELLED MIRROR / MOLATO	ANTIQUE EFFECT MIRROR / ANTICATO	
✓	✓	✓	

893

Beg. XVIII C. Tuscan



Art. 893A
(photo ref. / foto ref.)

Mirror frame
beg. XVIII C. Tuscan
Specchiera
inizio XVIII Sec. Toscano

DIS-PA3 A3 size print
with passe-partout
Disegno A3 con
passe-partout



Decoro
G006 Provence

ARTICLE / ARTICOLO		DIMENSIONS / DIMENSIONI	
893A		50 x h 60 cm	
893B		50 x h 70 cm	
893C		60 x h 80 cm	
893D		70 x h 90 cm	
MIRROR FINISHES / VARIANTI SPECCHIO			
PLAIN MIRROR / SPECCHIO LISCIO	BEVELLED MIRROR / MOLATO	ANTIQUE EFFECT MIRROR / ANTICATO	
✓	✓	✓	

1183

Italian



Art. 1183
(photo ref. / foto ref.)

Mirror frame
Italian
Specchiera
Italiano

DIS-PA4 A4 size print
with passe-partout
Disegno A4 con
passe-partout



Decoro
G038 Oro Pitti

DIMENSIONS / DIMENSIONI		
70 x h 80 cm		
MIRROR FINISHES / VARIANTI SPECCHIO		
PLAIN MIRROR / SPECCHIO LISCIO	BEVELLED MIRROR / MOLATO	ANTIQUE EFFECT MIRROR / ANTICATO
✓	✓	✓

1108

1st half XIX C. Charles French



Art. 1108
(photo ref. / foto ref.)

Tall vanity mirror frame
1st half XIX C. Charles French
Specchiera psiche
1° metà XIX Sec. Carlo Francese



Decoro
A029 Bolo e Oro

DIMENSIONS / DIMENSIONI		
86 x 40 x h 179 cm		
MIRROR FINISHES / VARIANTI SPECCHIO		
PLAIN MIRROR / SPECCHIO LISCIO	BEVELLED MIRROR / MOLATO	ANTIQUE EFFECT MIRROR / ANTICATO
✓	✓	✓

998

Half XVIII C. French



Art. 998
(photo ref. / foto ref.)

Tall vanity mirror frame
half XVIII C. French
Specchiera psiche
metà XVIII Sec. Francese



Decoro
A029 Bolo e Oro

DIMENSIONS / DIMENSIONI		
71 x 36 x h 177 cm		
MIRROR FINISHES / VARIANTI SPECCHIO		
PLAIN MIRROR / SPECCHIO LISCIO	BEVELLED MIRROR / MOLATO	ANTIQUE EFFECT MIRROR / ANTICATO
✓	✓	✓

DIS-PA4

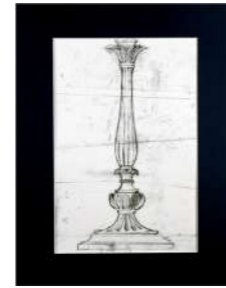

Art. DIS-PA4
(photo ref. / foto ref.)

A4 size print with passepartout
Disegno formato
A4 con passepartout

DIMENSIONS / DIMENSIONI

21 x 30 cm

DIS-PA3

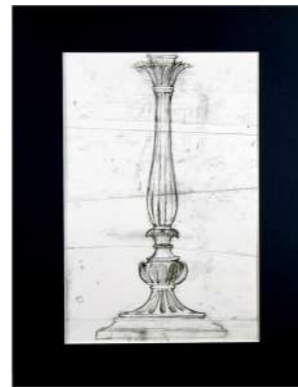

Art. DIS-PA3
(photo ref. / foto ref.)

A3 size print with passepartout
Disegno formato
A3 con passepartout

DIMENSIONS / DIMENSIONI

30 x 42 cm

DIS-A3

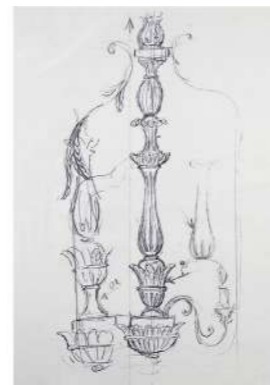

Art. DIS-A3
(photo ref. / foto ref.)

A3 size print
Disegno formato A3

DIMENSIONS / DIMENSIONI

30 x 42 cm

STA-PA



Art. STA-PA
(photo ref. / foto ref.)

Tuscan landscape print
Stampa paesaggio toscano

DIMENSIONS / DIMENSIONI

24 x 32 cm

STA-PB



Art. STA-PB
(photo ref. / foto ref.)

Flora and fauna print
with passepartout
Stampa flora e fauna
con passepartout

DIMENSIONS / DIMENSIONI

38 x 56 cm

STA-B



Art. STA-B
(photo ref. / foto ref.)

Flora and fauna print
Stampa flora e fauna

DIMENSIONS / DIMENSIONI

38 x 56 cm



CONSOLE TABLES CONSOLLE

— CONSOLE TABLES
Consolle

pag 250



CONSOLE TABLES CONSOLLE

The console tables in the collection are made of carved solid wood, and are available in all finish variants: **Standard, Elite, Luxury**, and with two types of top: **wood or marble** from the Roberto Giovannini selection.*

Le consolle della collezione sono realizzate in legno massello intagliato, sono disponibili in tutte le varianti di finitura: **Standard, Elite, Luxury**, e con due tipologie di piano: **in legno o marmo** a scelta tra la selezione Roberto Giovannini.*

CONSOLE TABLES_CONSOLLE

**OPTIONS FOR TOP
VARIANTI PIANO**
- WOOD / LEGNO
- MARBLE / MARBLE

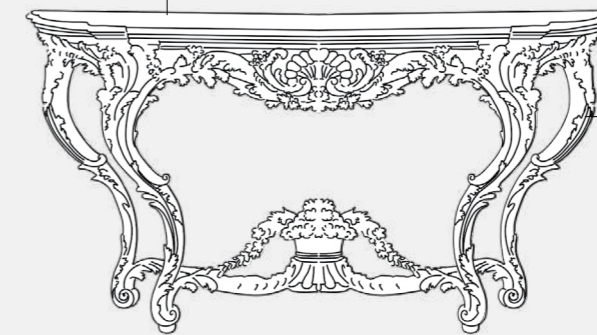

**WOOD FINISH
FINITURA LEGNO**
- STANDARD
- ELITE
- LUXURY

*Photos of the MARBLES available are in the technical catalogue or on the website www.robortogiovannini.com
Foto MARMI disponibili su catalogo tecnico o website www.robortogiovannini.com

509

Half XVIII C. Louis XV Francese



Art. 509
(photo ref. / foto ref.)

Shell console table
half XVIII C. Louis XV Francese
Consolle con conchiglia metà XVIII
Sec. Luigi XV Francese



Decoro
G079 Oro Leggero

DIMENSIONS / DIMENSIONI			
170 x 54 x h 91 cm			

OPTIONS FOR TOP / VARIANTI PIANO			
WOOD / LEGNO	MARBLE / MARMO		
	STANDARD	ELITE A	ELITE B
✓	✓	✓	✓

731GS

Half XVIII C. Venetian



Art. 731GS
(photo ref. / foto ref.)

Console table with cross bar
half XVIII C. Venetian
Consolle
metà XVIII Sec. Veneziano



Decoro
A039 Oro Versailles

DIMENSIONS / DIMENSIONI			
150 x 53 x h 88 cm			

OPTIONS FOR TOP / VARIANTI PIANO			
WOOD / LEGNO	MARBLE / MARMO		
	STANDARD	ELITE A	ELITE B
✓	✓	✓	✓

878S

End XVIII C. Louis XVI French



878

End XVIII C. Louis XVI French



Art. 878
(photo ref. / foto ref.)

Console table with big ornament cross bar end XVIII C. Louis XVI French
Console con crociata a decoro grande fine XVIII Sec. Luigi XVI Francese



Decoro A039 Oro Versailles

DIMENSIONS / DIMENSIONI			
157 x 61 x h 90 cm			
OPTION FOR SMALL ORNAMENT / VARIANTE DECORO PICCOLO			
878S			
OPTIONS FOR TOP / VARIANTI PIANO			
WOOD / LEGNO	MARBLE / MARMO		
	STANDARD	ELITE A	ELITE B
✓	✓	✓	✓

304

Half XVIII C. Louis XV Francese



Art. 304

(photo ref. / foto ref.)

Central rosette console table
half XVIII C. Louis XV French
Consolle rosone centrale
metà XVIII Sec. Luigi XV French



Decoro
G065 Pickled Pine e Argento

DIMENSIONS / DIMENSIONI			
138 x 50 x h 88 cm			
OPTIONS FOR TOP / VARIANTI PIANO			
WOOD / LEGNO	MARBLE / MARMO		
	STANDARD	ELITE A	ELITE B
✓	✓	✓	✓



1230

Half XVII C. Louis XIV Tuscan



Art. 1230
(photo ref. / foto ref.)

4 legs console table
half XVII C. Louis XIV Tuscan
Consolle con foglie 4 gambe
metà XVII Sec. Luigi XIV Toscano



Decoro
G038 Oro Pitti

DIMENSIONS / DIMENSIONI			
178 x 58 x h 91 cm			

OPTIONS FOR TOP / VARIANTI PIANO			
WOOD / LEGNO	MARBLE / MARMO		
	STANDARD	ELITE A	ELITE B
✓	-	-	-

731

Half XVIII C. Venetian



Art. 731
(photo ref. / foto ref.)

Console table
half XVIII C. Venetian
Consolle
metà XVIII Sec. Veneziano



Decoro
G012 Greige

DIMENSIONS / DIMENSIONI			
122 x 53 x h 88 cm			

OPTIONS FOR TOP / VARIANTI PIANO			
WOOD / LEGNO	MARBLE / MARMO		
	STANDARD	ELITE A	ELITE B
✓	✓	✓	✓

1049

XVIII C. English



Art. 1049
(photo ref. / foto ref.)

Console table with lion's paw
XVIII C. English
Consolle con zampa di leone
XVIII Sec. Inglese



Decoro
G006 Provence

DIMENSIONS / DIMENSIONI			
153 x 56 x h 91 cm			

OPTIONS FOR TOP / VARIANTI PIANO			
WOOD / LEGNO	MARBLE / MARMO		
	STANDARD	ELITE A	ELITE B
✓	✓	✓	✓

1033G

End XVIII C. Neoclassical Piedmontese



Art. 1033G
(photo ref. / foto ref.)

4 legs rectangular console table
end XVIII C. Neoclassical Piedmontese
Consolle rettangolare 4 gambe
fine XVIII Sec. Neoclassico Piemontese



Decoro
G088 Rosso e Argento

DIMENSIONS / DIMENSIONI			
187 x 41 x h 89 cm			

OPTIONS FOR TOP / VARIANTI PIANO			
WOOD / LEGNO	MARBLE / MARMO		
	STANDARD	ELITE A	ELITE B
✓	✓	✓	✓

240G

I C. Roman



Art. 240G
(photo ref. / foto ref.)

3 lions console table
I C. Roman
Consolle 3 leoni
I Sec. Romano



Decoro
G008 Trianon

DIMENSIONS / DIMENSIONI	
180 x 42 x h 92 cm	

OPTIONS FOR TOP / VARIANTI PIANO			
WOOD / LEGNO	MARBLE / MARMO		
	STANDARD	ELITE A	ELITE B
✓	✓	✓	✓





1429

Neoclassical



Art. 1429
(photo ref. / foto ref.)

Console table
with leaves carving
Neoclassical
Consolle piccola
con fascia a foglie
Neoclassico



Decoro
G112 Renaissance

DIMENSIONS / DIMENSIONI	
1429P	141 x 54 x h 90,5 cm
1429	186 x 54 x h 90,5 cm

OPTIONS FOR TOP / VARIANTI PIANO			
WOOD / LEGNO	MARBLE / MARMO		
	STANDARD	ELITE A	ELITE B
✓	✓	✓	✓

551PL

End XVIII C. Louis XVI French

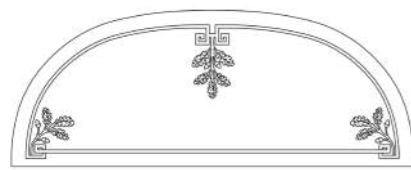

Engraved wooden top_incisione piano legno

Art. 551PL
(photo ref. / foto ref.)

Oak leaves console table
end XVIII C. Louis XVI French
Consolle foglie quercia
fine XVIII Sec. Luigi XVI Francese



Decoro
A036 Oro Antico

DIMENSIONS / DIMENSIONI			
146 x 56 x h 89 cm			

OPTIONS FOR TOP / VARIANTI PIANO			
WOOD / LEGNO	MARBLE / MARMO		
	STANDARD	ELITE A	ELITE B
✓	✓	✓	✓

210

Half XVII C. Louis XIV Francese



Art. 210
(photo ref. / foto ref.)

Console table with crossbar
half XVII C. Louis XIV French
Consolle con crociata
metà XVII Sec. Luigi XIV Francese



Decoro
G105 Argento Leggero

DIMENSIONS / DIMENSIONI			
140 x 65 x h 87 cm			

OPTIONS FOR TOP / VARIANTI PIANO			
WOOD / LEGNO	MARBLE / MARMO		
	STANDARD	ELITE A	ELITE B
✓	✓	✓	✓

584

End XVIII C. Neoclassical Piedmontese



Art. 584
(photo ref. / foto ref.)

Console table with bevelled insert
end XVIII C.
Neoclassical Piedmontese
Consolle con inserti molati
fine XVIII Sec.
Neoclassico Piemontese



Decoro
G042 Ebony e Oro

DIMENSIONS / DIMENSIONI			
139 x 55 x h 89 cm			
OPTIONS FOR TOP / VARIANTI PIANO			
WOOD / LEGNO	MARBLE / MARMO		
	STANDARD	ELITE A	ELITE B
✓	✓	✓	✓

1353

Half XVIII C. Napolitan



Art. 1353
(photo ref. / foto ref.)

4 legs console table
half XVIII C. Neapolitan
Consolle 4 gambe
metà XVIII Sec. Napoletano



Decoro
G081 Oro Antiquariato

DIMENSIONS / DIMENSIONI			
128 x 54 x h 92 cm			
OPTIONS FOR TOP / VARIANTI PIANO			
WOOD / LEGNO	MARBLE / MARMO		
	STANDARD	ELITE A	ELITE B
✓	✓	✓	✓

1450

XVIII C. Napolitan



Art. 1450
(photo ref. / foto ref.)

4 legs console table with roses
XVIII C. Neapolitan
Consolle 4 gambe con rose
XVIII sec. Napoletano



Decoro
G079 Oro Leggero

DIMENSIONS / DIMENSIONI			
93 x 40 x h 88 cm			
OPTIONS FOR TOP / VARIANTI PIANO			
WOOD / LEGNO	MARBLE / MARMO		
	STANDARD	ELITE A	ELITE B
✓	✓	✓	✓

717

Beg. XVIII C. French



Art. 717
(photo ref. / foto ref.)

Wall console table
beg. XVIII C. French
Consolle sospesa
inizio XVIII Sec. Francese



Decoro
A029 Bolo e Oro

DIMENSIONS / DIMENSIONI			
106 x 44 x h 82 cm			
OPTIONS FOR TOP / VARIANTI PIANO			
WOOD / LEGNO	MARBLE / MARMO		
	STANDARD	ELITE A	ELITE B
✓	✓	✓	✓

1324

XVIII C. Venetian



Art. 1324
(photo ref. / foto ref.)

Wall console table with cross-bar
XVIII C. Venetian
Consolle da parete con crociata
XVIII Sec. Veneziano



Decoro
G022 Argento Pitti

DIMENSIONS / DIMENSIONI			
110 x 45 x h 87 cm			
OPTIONS FOR TOP / VARIANTI PIANO			
WOOD / LEGNO	MARBLE / MARMO		
	STANDARD	ELITE A	ELITE B
✓	✓	✓	✓

1211

Half XVIII C. Louis XV French



Art. 1211
(photo ref. / foto ref.)

Console table with basement
half XVIII C. Louis XV French
Consolle con appoggio su base
metà XVIII Sec. Luigi XV Francese



Decoro
G042 Ebony e Oro

DIMENSIONS / DIMENSIONI			
115 x 50 x h 88 cm			
OPTIONS FOR TOP / VARIANTI PIANO			
WOOD / LEGNO	MARBLE / MARMO		
	STANDARD	ELITE A	ELITE B
✓	✓	✓	✓

688

Half XVIII C. Louis XV French



Art. 688
(photo ref. / foto ref.)

2 legs console table
half XVIII C. Louis XV French
Consolle 2 gambe
metà XVIII Sec. Luigi XV Francese



Decoro
G017 Ciliegio e Argento

DIMENSIONS / DIMENSIONI			
122 x 52 x h 88 cm			
OPTIONS FOR TOP / VARIANTI PIANO			
WOOD / LEGNO	MARBLE / MARMO		
	STANDARD	ELITE A	ELITE B
✓	✓	✓	✓

1116

End XVIII C. Neoclassical Piedmontese



Art. 1116
(photo ref. / foto ref.)

4 legs rectangular console table
with garlands
end XVIII C. Neoclassical Piedmontese
Consolle rettangolare 4 gambe
e ghirlande
fine XVIII Sec. Neoclassico Piemontese



Decoro
G032 Pickled Pine e Oro

DIMENSIONS / DIMENSIONI			
122 x 60 x h 90 cm			
OPTIONS FOR TOP / VARIANTI PIANO			
WOOD / LEGNO	MARBLE / MARMO		
	STANDARD	ELITE A	ELITE B
✓	✓	✓	✓

1157

End XVIII C. Neoclassical Italian



Art. 1157
(photo ref. / foto ref.)

2 legs rectangular console table
end XVIII C. Neoclassical Italian
Consolle rettangolare 4 gambe
fine XVIII Sec. Neoclassico Italiano



Decoro
G110 Barocco e Argento

DIMENSIONS / DIMENSIONI			
129 x 52 x h 92 cm			
OPTIONS FOR TOP / VARIANTI PIANO			
WOOD / LEGNO	MARBLE / MARMO		
	STANDARD	ELITE A	ELITE B
✓	✓	✓	✓

1283

Half XVIII C. Venetian



Art. 1283
(photo ref. / foto ref.)

4 legs console table with drawer
half XVIII C. Venetian
Consolle 4 gambe con cassetto
metà XVIII Sec. Veneziano



Decoro
G006 Provence

DIMENSIONS / DIMENSIONI			
137 x 47 x h 87 cm			

OPTIONS FOR TOP / VARIANTI PIANO			
WOOD / LEGNO	MARBLE / MARMO		
	STANDARD	ELITE A	ELITE B
✓	✓	✓	✓

1033

End XVIII C. Neoclassical Piedmontese



Art. 1033
(photo ref. / foto ref.)

2 legs rectangular console table
end XVIII C. Neoclassical Piedmontese
Consolle rettangolare 2 gambe
fine XVIII Sec. Neoclassico Piemontese



Decoro
G012 Greige

DIMENSIONS / DIMENSIONI			
140 x 36 x h 92 cm			

OPTIONS FOR TOP / VARIANTI PIANO			
WOOD / LEGNO	MARBLE / MARMO		
	STANDARD	ELITE A	ELITE B
✓	✓	✓	✓

851

End XVIII C. Louis XVI French



Art. 851
(photo ref. / foto ref.)

Garland console table
end XVIII C. Louis XVI French
Consolle con ghirlanda
fine XVIII Sec. Luigi Francese



Decoro
G061 Ciliegio e Oro

DIMENSIONS / DIMENSIONI			
87 x 39 x h 88 cm			

OPTIONS FOR TOP / VARIANTI PIANO			
WOOD / LEGNO	MARBLE / MARMO		
	STANDARD	ELITE A	ELITE B
✓	✓	✓	✓

1228

Half XVII C. Louis XIV Tuscan



Art. 1228
(photo ref. / foto ref.)

3 legs console table
half XVII C. Louis XIV Tuscan
Consolle con foglie 3 gambe
metà XVII Sec. Luigi XIV Toscano



Decoro
G038 Oro Pitti

DIMENSIONS / DIMENSIONI			
110 x 53 x h 91 cm			

OPTIONS FOR TOP / VARIANTI PIANO			
WOOD / LEGNO	MARBLE / MARMO		
	STANDARD	ELITE A	ELITE B
✓	✓	✓	✓

1281

End XVIII C. Neoclassical Tuscan



Art. 1281
(photo ref. / foto ref.)

Console table 3 legs
end XVIII C. Neoclassical Tuscan
Consolle 3 gambe
fine XVIII Sec. Neoclassico Toscano



Decoro
G009 Blanc

DIMENSIONS / DIMENSIONI			
107 x 47 x h 90 cm			

OPTIONS FOR TOP / VARIANTI PIANO			
WOOD / LEGNO	MARBLE / MARMO		
	STANDARD	ELITE A	ELITE B
✓	✓	✓	✓

722

End XVIII C. Neoclassical Italian



Art. 722
(photo ref. / foto ref.)

3 legs console table
end XVIII C. Neoclassical Italian
Consolle 3 gambe
fine XVIII Sec. Neoclassico Italiano



Decoro
A014 A.C.O.

DIMENSIONS / DIMENSIONI			
112 x 46 x h 91 cm			

OPTIONS FOR TOP / VARIANTI PIANO			
WOOD / LEGNO	MARBLE / MARMO		
	STANDARD	ELITE A	ELITE B
✓	✓	✓	✓



1345
XVIII C. Venetian



Art. 1345
(photo ref. / foto ref.)

Gueridon console table
XVIII C. Venetian
Consollina Gueridon
XVIII Sec. Veneziano



Decoro
A041 Impero

DIMENSIONS / DIMENSIONI			
67 x 38 x h 95 cm			

OPTIONS FOR TOP / VARIANTI PIANO			
WOOD / LEGNO	MARBLE / MARMO		
✓	STANDARD	ELITE A	ELITE B
	-	-	-



BEDROOMS CAMERE

— DOUBLE BEDS pag 288
Letti matrimoniali

— SINGLE BEDS pag 314
Letti singoli

— CHEST OF DRAWERS AND NIGHT TABLES pag 322
Cassettoni e comodini



LETTI MATRIMONIALI DOUBLE BED

The headboards are made of carved solid wood and are available in various sizes:

K – mattress 200x200

G – mattress 180x200

Standard – mattress 170x200

Queen – mattress 150x200

specified in each model's information sheet and are available in all finish variants: **Standard, Elite, Luxury**. They are supplied with plain padding, with capitonné padding (B) or with vertically slatted padding (D) (*some models only), with upholstery to be chosen from the Roberto Giovannini "Mosaico" and "Rondò" fabric selection or in neutral-coloured muslin or in the customer's fabric (C.O.M.) PE leather upholstery selected from the Roberto Giovannini collection or supplied by the customer (C.O.M.) is also available. Each headboard can be sold individually or complete with a wooden bed frame or as part of a sofa bed.

The carved solid wood bed frame includes the slatted base and is available in all finish variations **Standard, Elite, Luxury**. The sofa bed (sommier) can be fitted with carved and decorated wooden legs (art.3004) and is supplied with upholstery to be chosen from the Roberto Giovannini "Mosaico" and "Rondò" fabric selection or in neutral-coloured muslin or in the customer's own fabric (C.O.M.); it is also available with upholstery in PE leather selected from the Roberto Giovannini collection or supplied by the customer (C.O.M.). The sofa bed is available in the version which can be assembled and disassembled and/or in the container version (C), supplied with standard leg design. Certified fire retardant padding is available on request. Mattresses are always supplied separately; the recommended height is 25 cm.

Le testate letto sono realizzate in legno massello intagliato e sono disponibili in varie dimensioni:

K – materasso 200x200

G – materasso 180x200

Standard – materasso 170x200

Queen – materasso 150x200

specificate nella scheda di ciascun modello e sono disponibili in tutte le varianti di finiture:

Standard, Elite, Luxury. Sono fornite con imbottitura liscia, con imbottitura capitonné (B) o con imbottitura a doghe verticali (D) (*solo alcuni modelli), con rivestimento a scelta tra i tessuti selezione Roberto Giovannini "Mosaico" e "Rondò" oppure in mussolina di colore neutro o tessuto cliente (C.O.M.)

È disponibile anche la lavorazione in pelle PE selezionata dalla collezione Roberto Giovannini o fornita dal cliente (C.O.M.). Ogni testata letto può essere venduta singolarmente oppure completa di giroletto in legno o di sommier. Il giroletto in legno massello intagliato, include la rete a doghe ed è disponibile in tutte le varianti di finiture: **Standard, Elite, Luxury**.

Il sommier può essere completato con piedini in legno intagliato e decorato (art.3004) ed è fornito con rivestimento a scelta tra i tessuti selezione Roberto Giovannini "Mosaico" e "Rondò" oppure in mussolina di colore neutro o tessuto cliente (C.O.M.); è disponibile anche il rivestimento in pelle PE selezionata dalla collezione Roberto Giovannini o fornita dal cliente (C.O.M.) Il sommier a richiesta è disponibile nella versione smontabile e o nella versione contenitore (C), fornito con piedini standard.

Su richiesta è possibile avere imbottiture ignifughe certificate. I materassi sono sempre forniti a parte; l'altezza consigliata è di 25cm.

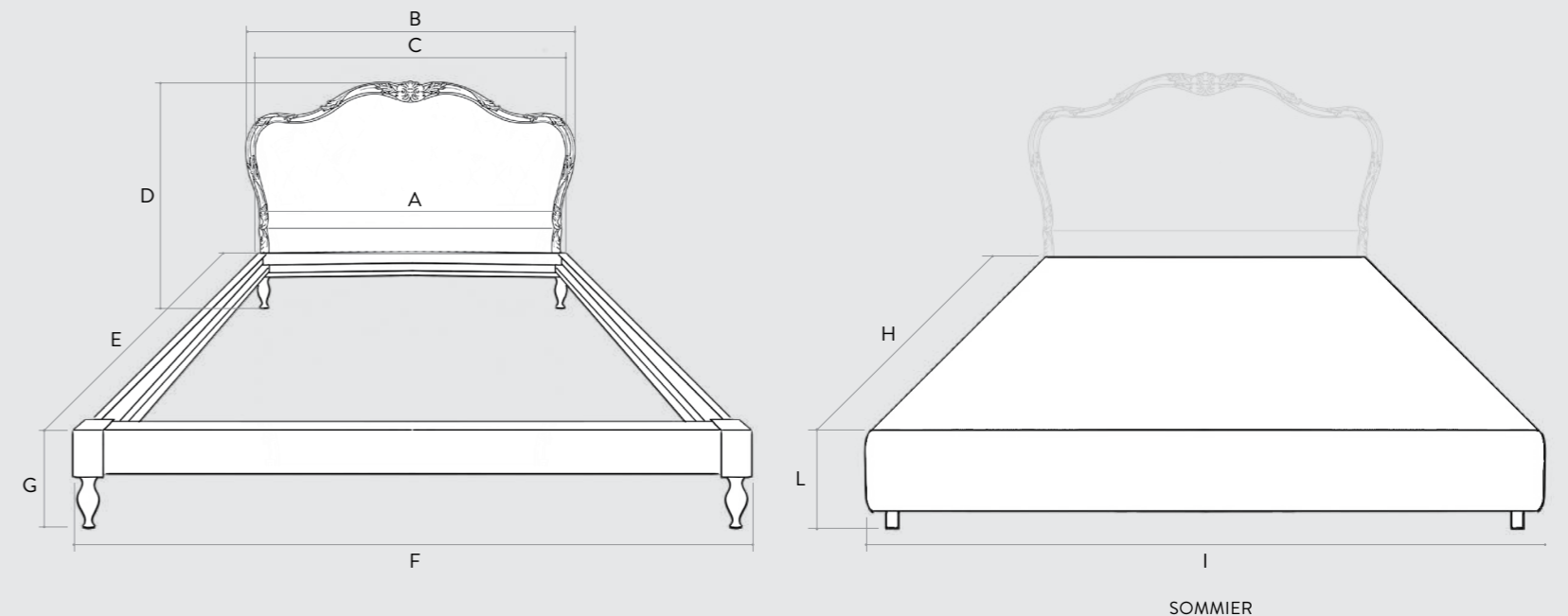

DOUBLE BEDS COMPOSITION_COMPOSIZIONE LETTI MATRIMONIALI

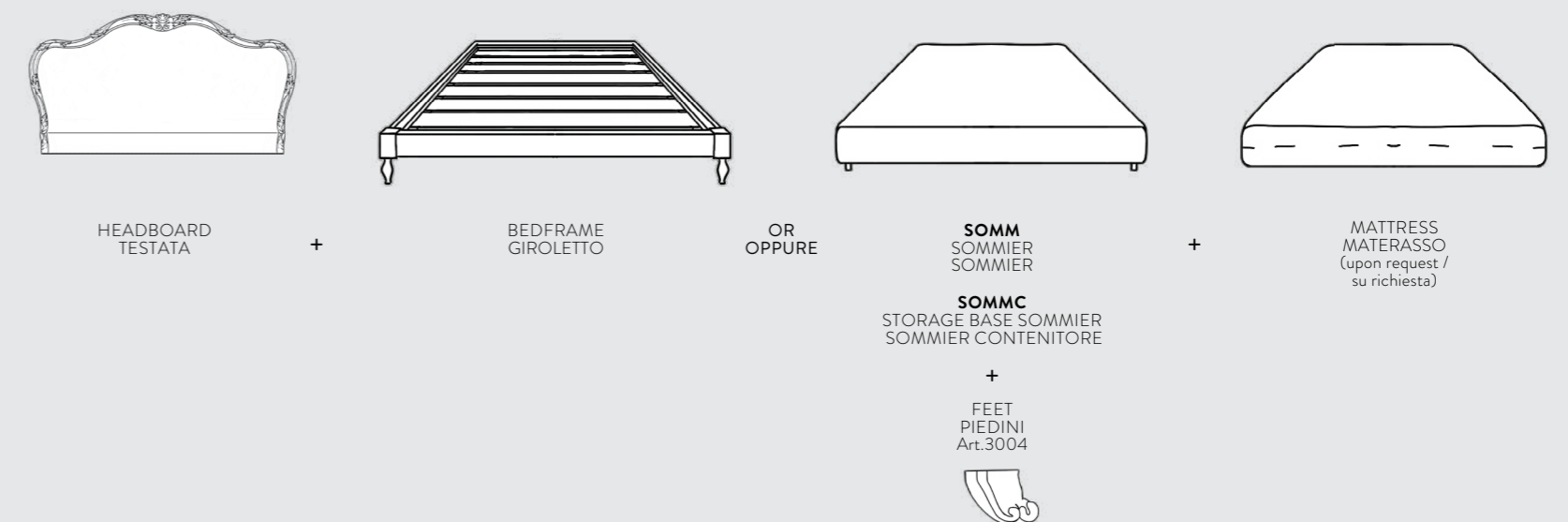

Ramage

End XVII C. Tuscan

Art. 1438



Art. 1438PASKB
(photo ref / rif. foto)

Ramage headboard
Stone version
buttoned padding
end XVII C. Tuscan
Letto Ramage
versione Stone
imbottitura capitonné
fine XVII sec. Toscano

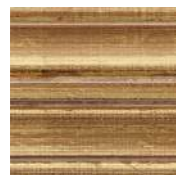

Decoro
G079 Oro Leggero

DOUBLE MATRIMONIALE	Q (QUEEN)	G (GRANDE)	K (KING)
OVERALL DIMENSIONS WITH SOMMIER / INGOMBRO MASSIMO CON SOMMIER			
214 x 204 x h 174 cm	-	214 x 204 x h 174 cm	234 x 204 x h 174 cm
OVERALL DIMENSIONS WITH BED FRAME (ART. 3005) / INGOMBRO MASSIMO CON GIROLETTO (ART. 3005)			
214 x 214 x h 174 cm	-	214 x 214 x h 174 cm	234 x 214 x h 174 cm
MATTRESS SIZE (NOT PROVIDED) / MATERASSO ABBINATO (NON FORNITO)			
170 x 200 x h 25/30 cm	-	180 x 200 x h 25/30 cm	200 x 200 x h 25/30 cm

HEADBOARD TYPE / VERSIONE TESTATA		
PAS (STONE)	PV (MIRROR)	SILK

HEADBOARD PADDING / IMBOTTITURA TESTATA				
PLAIN / LISCIA	B (BUTTONED / CAPITONNÉ)	BPE (BUTTONED LEATHER / CAPITONNÉ PELLE)	D (VERTICAL SLATS / DOGHE VERTICALI)	DPE (VERTICAL LEATHER SLATS / DOGHE VERTICALI IN PELLE)

SOMMIER UPHOLSTERY / IMBOTTITURA SOMMIER	
FABRIC / TESSUTO	PE (LEATHER / PELLE)



Versailles

Half XVIII C. Louis XV Italian

Art. 1365



Art. 1365K
(photo ref / rif. foto)

Headboard
half XVIII sec. Louis XV Italian
Testata letto Bergère
metà XVIII C. Luigi XV Italiano

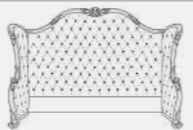
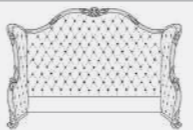

Decoro
A077 Oro Francese

DOUBLE MATRIMONIALE	Q (QUEEN)	G (GRANDE)	K (KING)
OVERALL DIMENSIONS WITH SOMMIER / INGOMBRO MASSIMO CON SOMMIER			
-	-	222 x 210 x h 165 cm	242 x 210 x h 165 cm
MATTRESS SIZE (UPON REQUEST) / MATERASSO ABBINATO (SU RICHIESTA)			
-	-	180 x 200 x h 25/30 cm	200 x 200 x h 25/30 cm
HEADBOARD PADDING / IMBOTTITURA TESTATA			
			
PLAIN / LISCIA	B (BUTTONED / CAPITONNÉ)	BPE (BUTTONED IN LEATHER / CAPITONNÉ PELLE)	
SOMMIER UPHOLSTERY / IMBOTTITURA SOMMIER			
FABRIC / TESSUTO		PE (LEATHER / PELLE)	



Versailles

Half XVIII C. Louis XV Italian

Art. 1365K



Pitti

2° Half XVII C. Baroque Italian

Art. 1133



Art. 1133
(photo ref / rif. foto)

Pitti headboard
2nd half XVII C. Baroque Italian
with bedframe art.3005
Testata letto Pitti
2° metà XVII Sec. Barocco Italiano
con giroletto art.3005

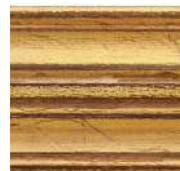

Decoro
G038 Oro Pitti

DOUBLE MATRIMONIALE	Q (QUEEN)	G (GRANDE)	K (KING)
OVERALL DIMENSIONS WITH SOMMIER / INGOMBRO MASSIMO CON SOMMIER			
225 x 210 x h 173 cm	-	225 x 210 x h 173 cm	241 x 210 x h 174 cm
OVERALL DIMENSIONS WITH BED FRAME (ART. 3005) / INGOMBRO MASSIMO CON GIROLETTO (ART. 3005)			
225 x 214 x h 173 cm	-	225 x 214 x h 173 cm	241 x 214 x h 174 cm
MATTRESS SIZE (NOT PROVIDED) / MATERASSO ABBINATO (NON FORNITO)			
170 x 200 x h 25 cm	-	180 x 200 x h 25 cm	200 x 200 x h 25 cm
HEADBOARD PADDING / IMBOTTITURA TESTATA			
PLAIN / LISCIA	B (BUTTONED / CAPITONNÉ)	BPE (BUTTONED LEATHER / CAPITONNÉ PELLE)	
SOMMIER UPHOLSTERY / IMBOTTITURA SOMMIER			
FABRIC / TESSUTO		PE (LEATHER / PELLE)	

King Palace

Half XVIII C. Chippendale English

Art. 1421



Art. 1421K
(photo ref. / rif. foto)

King Palace headboard
half XVIII C. Chippendale English
Testata letto King Palace
metà XVIII Sec. Chippendale Inglese



Decoro
G035 Oro Decapè Antico

DOUBLE MATRIMONIALE	Q (QUEEN)	G (GRANDE)	K (KING)
MAXIMUM FOOTPRINT WITH SOMMIER / INGOMBRO MASSIMO CON SOMMIER			
-	-	210 x 210 x h 195 cm	230 x 210 x h 195 cm
MAXIMUM FOOTPRINT WITH BED FRAME (ART. 3005) / INGOMBRO MASSIMO CON GIROLETTO (ART. 3005)			
-	-	210 x 214 x h 195 cm	230 x 214 x h 195 cm
MATCHED MATTRESS (NOT PROVIDED) / MATERASSO ABBINATO (NON FORNITO)			
-	-	180 x 200 x h 25 cm	200 x 200 x h 25 cm
HEADBOARD PADDING / IMBOTTITURA TESTATA			
PLAIN / LISCIA	B (BUTTONED / CAPITONNÉ)	BPE (BUTTONED LEATHER / CAPITONNÉ PELLE)	
SOMMIER UPHOLSTERY / IMBOTTITURA SOMMIER			
FABRIC / TESSUTO		PE (LEATHER / PELLE)	

Fiorellacci

XVIII C. Tuscan

Art. 1318





Art. 1318
(photo ref. / rif. foto)

Fiorellacci headboard
XVIII C. Tuscan
with bedframe Art. 3007
Testata letto Fiorellacci
XVIII Sec. Toscano
con giroletto Art. 3007



Decoro
G011 Vanwood

DOUBLE MATRIMONIALE	Q (QUEEN)	G (GRANDE)	K (KING)
OVERALL DIMENSIONS WITH SOMMIER / INGOMBRO MASSIMO CON SOMMIER			
209 x 210 x h 168 cm	-	-	246 x 210 x h 170 cm
OVERALL DIMENSIONS WITH BED FRAME (ART.3007) / INGOMBRO MASSIMO CON GIROLETTO (ART.3007)			
209 x 214 x h 168 cm	-	-	246 x 214 x h 170 cm
MATTRESS SIZE (NOT PROVIDED) / MATERASSO ABBINATO (NON FORNITO)			
170 x 200 x h 25 cm	-	-	200 x 200 x h 25 cm

HEADBOARD PADDING / IMBOTTITURA TESTATA		
		
PLAIN / LISCIA	B (BUTTONED / CAPITONNÉ)	BPE (BUTTONED LEATHER / CAPITONNÉ PELLE)

SOMMIER UPHOLSTERY / IMBOTTITURA SOMMIER	
FABRIC / TESSUTO	PE (LEATHER / PELLE)

Laguna

XVIII Sec. Venetian

Art. 1248





Art. 1248B
(photo ref / rif. foto)

Laguna buttoned headboard
XVIII C. Venetian
with bedframe Art. 3002
Testata letto Laguna capitonné
XVIII Sec. Veneziano
con giroletto Art. 3002



Decoro
G010 Florence

DOUBLE MATRIMONIALE	Q (QUEEN)	G (GRANDE)	K (KING)
OVERALL DIMENSIONS WITH SOMMIER / INGOMBRO MASSIMO CON SOMMIER			
203 x 210 x h 156 cm	-	213 x 210 x h 156 cm	233 x 210 x h 161 cm
OVERALL DIMENSIONS WITH BED FRAME (ART. 3001/3002) / INGOMBRO MASSIMO CON GIROLETTO (ART. 3001/3002)			
203 x 213 x h 156 cm	-	213 x 213 x h 156 cm	233 x 213 x h 161 cm
MATTRESS SIZE (NOT PROVIDED) / MATERASSO ABBINATO (NON FORNITO)			
170 x 200 x h 25 cm	-	180 x 200 x h 25 cm	200 x 200 x h 25 cm

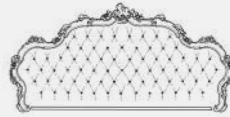
HEADBOARD PADDING / IMBOTTITURA TESTATA		
		
PLAIN / LISCIA	B (BUTTONED / CAPITONNÉ)	BPE (BUTTONED LEATHER / CAPITONNÉ PELLE)

SOMMIER UPHOLSTERY / IMBOTTITURA SOMMIER	
FABRIC / TESSUTO	PE (LEATHER / PELLE)

Laguna
Art. 1248KB



Impero

End XVII C. Neoclassical Italian

Art. 1386





Art. 1386K
(photo ref / rif. foto)

Impero headboard
end XVIII C. Neoclassical Italian
with bedframe Art. 3008K
Testata letto Impero
fine XVIII sec. Neoclassico Italiano
con giroletto Art.3008K



Decoro
G038 Oro Pitti

DOUBLE MATRIMONIALE	Q (QUEEN)	G (GRANDE)	K (KING)
OVERALL DIMENSIONS WITH SOMMIER / INGOMBRO MASSIMO CON SOMMIER			
-	-	206 x 210 x h 144 cm	226 x 210 x h 144 cm
OVERALL DIMENSIONS WITH BED FRAME (ART. 3008K) / INGOMBRO MASSIMO CON GIROLETTO (ART. 3008K)			
-	-	206 x 211 x h 144 cm	226 x 211 x h 144 cm
MATTRESS SIZE (NOT PROVIDED) / MATERASSO ABBINATO (NON FORNITO)			
-	-	180 x 200 x h 25 cm	200 x 200 x h 25 cm

HEADBOARD PADDING / IMBOTTITURA TESTATA		
		
PLAIN / LISCIA	B (BUTTONED / CAPITONNÉ)	BPE (BUTTONED LEATHER / CAPITONNÉ PELLE)

SOMMIER UPHOLSTERY / IMBOTTITURA SOMMIER	
FABRIC / TESSUTO	PE (LEATHER / PELLE)

Soleil

End XVIII Sec. Louis XV French

Art. 1370



Art. 1370GB
(photo ref. / rif. foto)

Soleil headboard with oak leaves
end XVIII C. Louis XV French
Testata letto Soleil con foglie quercia
fine XVIII Sec. Luigi XV Francese



Decoro
G105 Argento Leggero

DOUBLE MATRIMONIALE	Q (QUEEN)	G (GRANDE)	K (KING)
OVERALL DIMENSIONS WITH SOMMIER / INGOMBRO MASSIMO CON SOMMIER			
-	158 x 210 x h 162 cm	188 x 210 x h 162 cm	208 x 210 x h 162 cm
OVERALL DIMENSIONS WITH BED FRAME (ART. 3001/3002) / INGOMBRO MASSIMO CON GIROLETTO (ART. 3001/3002)			
-	160 x 213 x h 162 cm	194 x 213 x h 162 cm	213 x 213 x h 162 cm
MATTRESS SIZE (NOT PROVIDED) / MATERASSO ABBINATO (NON FORNITO)			
-	150 x 200 x h 25 cm	180 x 200 x h 25 cm	200 x 200 x h 25 cm

HEADBOARD PADDING / IMBOTTITURA TESTATA	
	
B (CAPITONNÉ)	BPE (CAPITONNÉ PELLE)

SOMMIER UPHOLSTERY / IMBOTTITURA SOMMIER	
FABRIC / TESSUTO	PE (LEATHER / PELLE)

Rialto

XVIII C. Venetian

Art. 1343





Art. 1343
(photo ref / rif. foto)

Rialto headboard with sommier and wooden legs Art. 3004 XVIII C. Venetian Testata letto Rialto con sommier e piedini in legno Art. 3004 XVIII Sec. Veneziano



Decoro
G079 Oro Leggero

DOUBLE MATRIMONIALE	Q (QUEEN)	G (GRANDE)	K (KING)
OVERALL DIMENSIONS WITH SOMMIER / INGOMBRO MASSIMO CON SOMMIER			
199 x 210 x h 153 cm	-	213 x 210 x h 153 cm	233 x 210 x h 153 cm
OVERALL DIMENSIONS WITH BED FRAME (ART. 3001/3002/3003) / INGOMBRO MASSIMO CON GIROLETTO (ART. 3001/3002/3003)			
199 x 213 x h 153 cm	-	213 x 213 x h 153 cm	233 x 213 x h 153 cm
MATTRESS SIZE (NOT PROVIDED) / MATERASSO ABBINATO (NON FORNITO)			
170 x 200 x h 25 cm	-	180 x 200 x h 25 cm	200 x 200 x h 25 cm
HEADBOARD PADDING / IMBOTTITURA TESTATA			
			
PLAIN / LISCIA	B (BUTTONED / CAPITONNÉ)	BPE (BUTTONED LEATHER / CAPITONNÉ PELLE)	
SOMMIER UPHOLSTERY / IMBOTTITURA SOMMIER			
FABRIC / TESSUTO		PE (LEATHER / PELLE)	



Borghese

Half XVIII C. Roman
Art. 1290



Art. 1290B
(photo ref / rif. foto)

Borghese buttoned headboard
half XVIII C. Roman
with bedframe Art. 3003
Testata letto Borghese capitonné
metà XVIII Sec. Romano
con giroletto Art. 3003



Decoro
G008 Trianon

DOUBLE MATRIMONIALE	Q (QUEEN)	G (GRANDE)	K (KING)
OVERALL DIMENSIONS WITH SOMMIER / INGOMBRO MASSIMO CON SOMMIER			
203 x 210 x h 146 cm	-	-	228 x 210 x h 146 cm
OVERALL DIMENSIONS WITH BED FRAME (ART. 3003) / INGOMBRO MASSIMO CON GIROLETTO (ART. 3003)			
203 x 213 x h 146 cm	-	-	228 x 213 x h 146 cm
MATTRESS SIZE (NOT PROVIDED) / MATERASSO ABBINATO (NON FORNITO)			
170 x 200 x h 25 cm	-	-	200 x 200 x h 25 cm

HEADBOARD PADDING / IMBOTTITURA TESTATA

		
PLAIN / LISCIA	B (BUTTONED / CAPITONNÉ)	BPE (BUTTONED LEATHER / CAPITONNÉ PELLE)

SOMMIER UPHOLSTERY / IMBOTTITURA SOMMIER

FABRIC / TESSUTO	PE (LEATHER / PELLE)
------------------	----------------------

Tivoli

Half XVIII C. Roman
Art. 1290RKB



Art. 1290RKB
(photo ref. / rif. foto)

Tivoli buttoned headboard
half XVIII C. Roman
with bedframe Art. 3003K
Testata letto Tivoli capitonné
metà XVIII Sec. Romano
con giroletto Art. 3003K

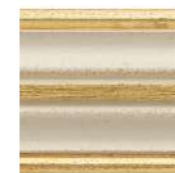

Decoro
G003 Magnolia

DOUBLE MATRIMONIALE	Q (QUEEN)	G (GRANDE)	K (KING)
OVERALL DIMENSIONS WITH SOMMIER / INGOMBRO MASSIMO CON SOMMIER			
-	-	-	228 x 210 x h 155 cm
OVERALL DIMENSIONS WITH BED FRAME (ART. 3003K) / INGOMBRO MASSIMO CON GIROLETTO (ART. 3003K)			
-	-	-	228 x 213 x h 155 cm
MATTRESS SIZE (NOT PROVIDED) / MATERASSO ABBINATO (NON FORNITO)			
-	-	-	200 x 200 x h 25 cm

HEADBOARD PADDING / IMBOTTITURA TESTATA

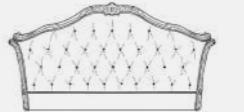
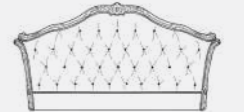
		
PLAIN / LISCIA	B (BUTTONED / CAPITONNÉ)	BPE (BUTTONED LEATHER / CAPITONNÉ PELLE)

SOMMIER UPHOLSTERY / IMBOTTITURA SOMMIER

FABRIC / TESSUTO	PE (LEATHER / PELLE)
------------------	----------------------

Rose

Art. 1199



Art. 1199
(photo ref. / rif. foto)

Rose headboard with sommier and wooden legs Art. 3004
Testata letto Rose con sommier e piedini in legno Art. 3004

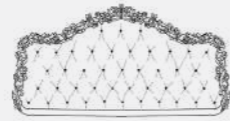
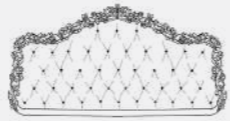

Decoro G006 Provence

DOUBLE MATRIMONIALE	Q (QUEEN)	G (GRANDE)	K (KING)
OVERALL DIMENSIONS WITH SOMMIER / INGOMBRO MASSIMO CON SOMMIER			
193 x 210 x h 116 cm	-	193 x 210 x h 116 cm	-
OVERALL DIMENSIONS WITH BED FRAME (ART. 3001/3002) / INGOMBRO MASSIMO CON GIROLETTO (ART. 3001/3002)			
193 x 213 x h 116 cm	-	193 x 213 x h 116 cm	-
MATTRESS SIZE (NOT PROVIDED) / MATERASSO ABBINATO (NON FORNITO)			
170 x 200 x h 25 cm	-	180 x 200 x h 25 cm	-
HEADBOARD PADDING / IMBOTTITURA TESTATA			
			
PLAIN / LISCIA	B (BUTTONED / CAPITONNÉ)	BPE (BUTTONED LEATHER / CAPITONNÉ PELLE)	
SOMMIER UPHOLSTERY / IMBOTTITURA SOMMIER			
FABRIC / TESSUTO		PE (LEATHER / PELLE)	

Fiocco

Half XVIII C. Louis XVI French

Art. 442





Art. 442
(photo ref / rif. foto)

Fiocco headboard ribbon carving with sommier and wooden legs Art. 3004 end XVIII C. Louis XVI French
Testata letto Fiocco con sommier e piedini in legno Art. 3004 fine XVIII Sec. Luigi XVI Francese



Decoro A024 Argento Luce

DOUBLE MATRIMONIALE	Q (QUEEN)	G (GRANDE)	K (KING)
OVERALL DIMENSIONS WITH SOMMIER / INGOMBRO MASSIMO CON SOMMIER			
183 x 210 x h 147 cm	155 x 210 x h 147 cm	183 x 210 x h 147 cm	200 x 210 x h 147 cm
OVERALL DIMENSIONS WITH BED FRAME (ART. 3001/3002) / INGOMBRO MASSIMO CON GIROLETTO (ART. 3001/3002)			
183 x 213 x h 147 cm	160 x 213 x h 147 cm	190 x 213 x h 147 cm	213 x 213 x h 147 cm
MATTRESS SIZE (NOT PROVIDED) / MATERASSO ABBINATO (NON FORNITO)			
170 x 200 x h 25 cm	150 x 200 x h 25 cm	180 x 200 x h 25 cm	200 x 200 x h 25 cm
HEADBOARD PADDING / IMBOTTITURA TESTATA			
			
PLAIN / LISCIA	B (BUTTONED / CAPITONNÉ)	BPE (BUTTONED LEATHER / CAPITONNÉ PELLE)	
SOMMIER UPHOLSTERY / IMBOTTITURA SOMMIER			
FABRIC / TESSUTO		PE (LEATHER / PELLE)	

Athena

End XVIII C. Neoclassical

Art. 1305





Art. 1305
(photo ref / rif. foto)

Athena headboard with sommier and wooden legs Art. 3004 end XVIII C. Neoclassical Testata letto Athena con sommier e piedini in legno Art. 3004 fine XVIII Sec. Neoclassico



Decoro G079 Oro Leggero

DOUBLE MATRIMONIALE	Q (QUEEN)	G (GRANDE)	K (KING)
OVERALL DIMENSIONS WITH SOMMIER / INGOMBRO MASSIMO CON SOMMIER			
187 x 210 x h 149 cm	-	187 x 210 x h 149 cm	218 x 210 x h 149 cm
OVERALL DIMENSIONS WITH BED FRAME (ART. 3001) / INGOMBRO MASSIMO CON GIROLETTO (ART. 3001)			
187 x 213 x h 149 cm	-	190 x 213 x h 149 cm	218 x 213 x h 149 cm
MATTRESS SIZE (NOT PROVIDED) / MATERASSO ABBINATO (NON FORNITO)			
170 x 200 x h 25 cm	-	180 x 200 x h 25 cm	200 x 200 x h 25 cm
HEADBOARD PADDING / IMBOTTITURA TESTATA			
			
PLAIN / LISCIA	B (BUTTONED / CAPITONNÉ)	BPE (BUTTONED LEATHER / CAPITONNÉ PELLE)	
SOMMIER UPHOLSTERY / IMBOTTITURA SOMMIER			
FABRIC / TESSUTO		PE (LEATHER / PELLE)	

Colonne

XVII C. Tuscan

Art. 1397





Art. 1397G
(photo ref. / rif. foto)

Colonne bed XVIII C. Tuscan Letto Colonne XVIII Sec. Toscano



Decoro G095 Antico Veneziano

DOUBLE MATRIMONIALE	Q (QUEEN)	G (GRANDE)	K (KING)
OVERALL DIMENSIONS / INGOMBRO MASSIMO			
-	-	209 x 196 x h 225 cm	229 x 216 x h 225 cm
MATTRESS SIZE (NOT PROVIDED) / MATERASSO ABBINATO (NON FORNITO)			
-	-	180 x 200 x h 25 cm	200 x 200 x h 25 cm
HEADBOARD PADDING / IMBOTTITURA TESTATA			
			
PLAIN / LISCIA	B (BUTTONED / CAPITONNÉ)	BPE (BUTTONED LEATHER / CAPITONNÉ PELLE)	
SOMMIER UPHOLSTERY / IMBOTTITURA SOMMIER			
FABRIC / TESSUTO		PE (LEATHER / PELLE)	

Decoro

Half XVIII C. Louis XV French

Art. 1146



Art. 1146K
(photo ref / rif. foto)

Decoro headboard
with engraved decoration
half XVIII C. Louis XV French
Testata letto Decoro con pannello inciso
metà XVIII Sec. Luigi XV Francese



Decoro
G095 Antico Veneziano

DOUBLE MATRIMONIALE	Q (QUEEN)	G (GRANDE)	K (KING)
OVERALL DIMENSIONS WITH SOMMIER / INGOMBRO MASSIMO CON SOMMIER			
183 x 210 x h 161 cm	-	-	213 x 210 x h 161 cm
OVERALL DIMENSIONS WITH BED FRAME (ART. 3001/3002) / INGOMBRO MASSIMO CON GIROLETTO (ART. 3001/3002)			
183 x 213 x h 161 cm	-	-	213 x 213 x h 161 cm
MATTRESS SIZE (NOT PROVIDED) / MATERASSO ABBINATO (NON FORNITO)			
170 x 200 x h 25 cm	-	-	200 x 200 x h 25 cm
SOMMIER UPHOLSTERY / IMBOTTITURA SOMMIER			
FABRIC / TESSUTO		PE (LEATHER / PELLE)	

Girasole

End XVII C. Baroque Venetian

Art. 773



Art. 773
(photo ref / rif. foto)

Girasole headboard
with sommier
and wooden legs Art. 3004
end XVII C. Baroque Venetian
Testata letto Girasole
con sommier
e piedini in legno Art. 3004
fine XVII Sec. Barocco Veneziano



Decoro
G003 Magnolia

DOUBLE MATRIMONIALE	Q (QUEEN)	G (GRANDE)	K (KING)
OVERALL DIMENSIONS WITH SOMMIER / INGOMBRO MASSIMO CON SOMMIER			
205 x 210 x h 139 cm	-	205 x 210 x h 139 cm	-
OVERALL DIMENSIONS WITH BED FRAME (ART. 3001/3002) / INGOMBRO MASSIMO CON GIROLETTO (ART. 3001/3002)			
205 x 213 x h 139 cm	-	205 x 213 x h 139 cm	-
MATTRESS SIZE (NOT PROVIDED) / MATERASSO ABBINATO (NON FORNITO)			
170 x 200 x h 25 cm	-	180 x 200 x h 25 cm	-
SOMMIER UPHOLSTERY / IMBOTTITURA SOMMIER			
FABRIC / TESSUTO		PE (LEATHER / PELLE)	

LETTI SINGOLI SINGLE BED

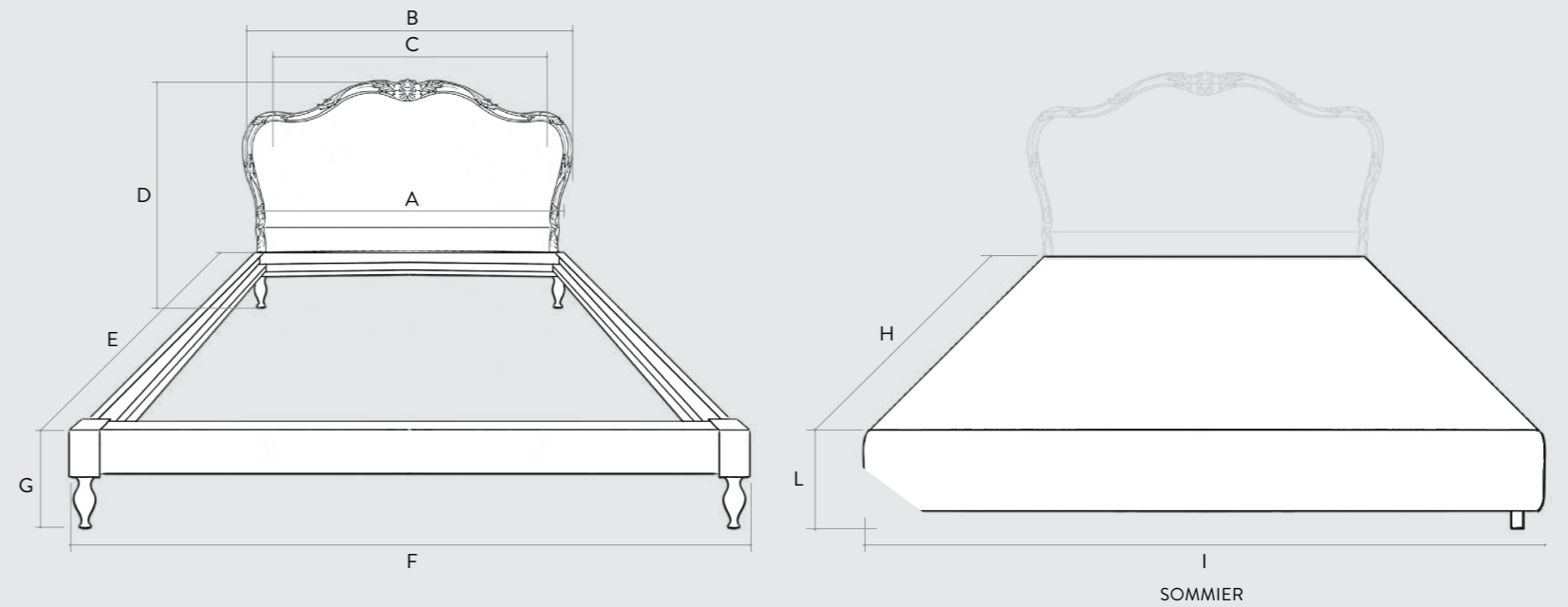

SINGLE BEDS details as double bed
but measurements are:
P – mattress 100x200
S – mattress 120x200

LETTI SINGOLI dettagli come matrimoniali
ma misure:
P – materasso 100x200
S – materasso 120x200

COMPOSITION OF SINGLE BEDS_COMPOSIZIONE LETTI SINGOLI

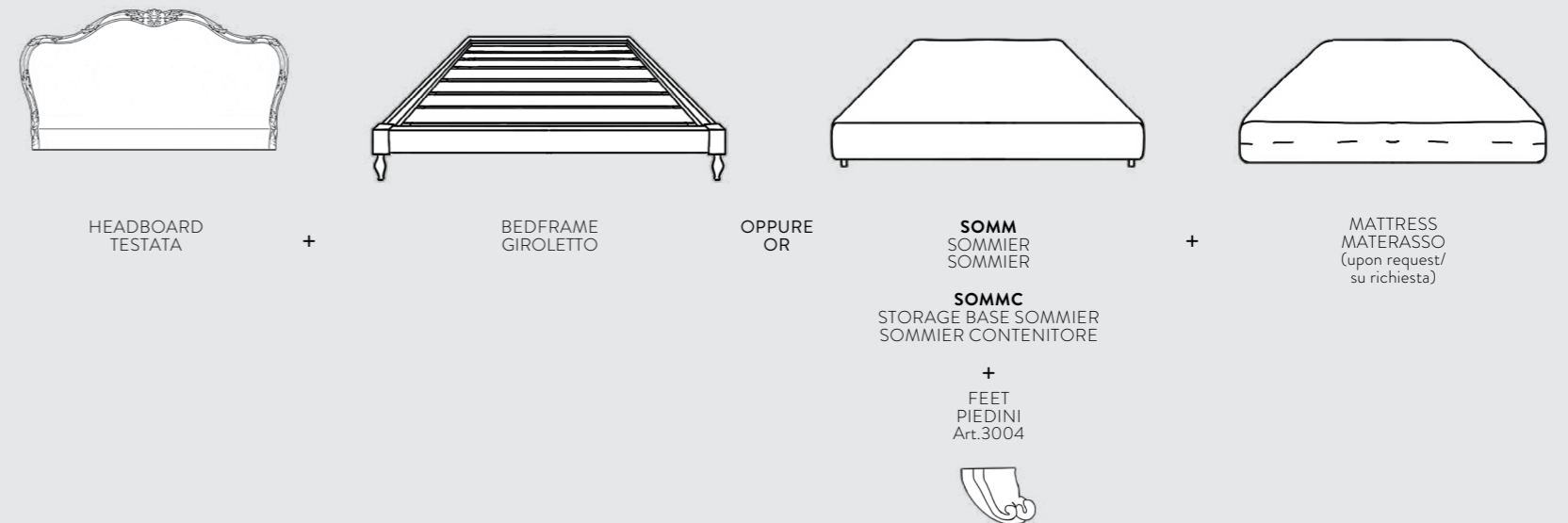



Fiocco

End XVIII C. Louis XVI French

Art. 442





Art. 442S

(photo ref. / rif. foto)

Fiocco single headboard
end XVIII Sec. Louis XVI French
with sommier
and wooden legs Art. 3004
Testata letto Fiocco singola
con sommier e piedini Art. 3004
fine XVIII Sec. Luigi XVI Francese



Decoro
G009 Blanc

P	S	
OVERALL DIMENSIONS WITH SOMMIER / INGOMBRO MASSIMO CON SOMMIER		
113 x 210 x h 138 cm	133 x 210 x h 138 cm	
OVERALL DIMENSIONS WITH BED FRAME (ART. 3001/3002) / INGOMBRO MASSIMO CON GIROLETTO (ART. 3001/3002)		
113 x 213 x h 138 cm	133 x 213 x h 138 cm	
MATTRESS SIZE (NOT PROVIDED) / MATERASSO ABBINATO (NON FORNITO)		
100 x 200 x h 25 cm	120 x 200 x h 25 cm	
HEADBOARD PADDING / IMBOTTITURA TESTATA		
		
PLAIN / LISCIA	B (BUTTONED / CAPITONNÉ)	BPE (BUTTONED LEATHER / CAPITONNÉ PELLE)
SOMMIER UPHOLSTERY / IMBOTTITURA SOMMIER		
FABRIC / TESSUTO	PE (LEATHER / PELLE)	

Borghese

Half XVIII C. Roman

Art. 1290





Art. 1290S
(photo ref. / rif. foto)

Borghese single headboard half XVIII C. Roman with sommier and wooden legs Art. 3004 Testata letto Borghese singola metà XVIII Sec. Romano con sommier e piedini Art. 3004 fine XVIII Sec. Luigi XVI Francese



Decoro A013 Vogue

P	S	
OVERALL DIMENSIONS WITH SOMMIER / INGOMBRO MASSIMO CON SOMMIER		
130 x 210 x h 137 cm	150 x 210 x h 137 cm	
OVERALL DIMENSIONS WITH BED FRAME (ART. 3001/3002) / INGOMBRO MASSIMO CON GIROLETTO (ART. 3001/3002)		
130 x 213 x h 137 cm	150 x 213 x h 137 cm	
MATRESS SIZE (NOT PROVIDED) / MATERASSO ABBINATO (NON FORNITO)		
100 x 200 x h 25 cm	120 x 200 x h 25 cm	
HEADBOARD PADDING / IMBOTTITURA TESTATA		
		
PLAIN / LISCIA	B (BUTTONED / CAPITONNÉ)	BPE (BUTTONED LEATHER / CAPITONNÉ PELLE)
SOMMIER UPHOLSTERY / IMBOTTITURA SOMMIER		
FABRIC / TESSUTO	PE (LEATHER / PELLE)	

Laguna

Half XVIII C. Venetian

Art. 1368





Art. 1368S
(photo ref. / rif. foto)

Laguna single headboard half XVIII C. Venetian 3002S wooden bedframe base Testata letto Laguna singola metà XVIII Sec. Veneziano con giroletto Art. 3002S



Decoro G017 Ciliegio e Argento

P	S	
OVERALL DIMENSIONS WITH SOMMIER / INGOMBRO MASSIMO CON SOMMIER		
131 x 210 x h 163 cm	151 x 210 x h 163 cm	
OVERALL DIMENSIONS WITH BED FRAME (ART. 3001/3002) / INGOMBRO MASSIMO CON GIROLETTO (ART. 3001/3002)		
131 x 213 x h 163 cm	151 x 213 x h 163 cm	
MATRESS SIZE (NOT PROVIDED) / MATERASSO ABBINATO (NON FORNITO)		
100 x 200 x h 25 cm	120 x 200 x h 25 cm	
HEADBOARD PADDING / IMBOTTITURA TESTATA		
		
PLAIN / LISCIA	B (BUTTONED / CAPITONNÉ)	BPE (BUTTONED LEATHER / CAPITONNÉ PELLE)
SOMMIER UPHOLSTERY / IMBOTTITURA SOMMIER		
FABRIC / TESSUTO	PE (LEATHER / PELLE)	

Soleil

End XVIII C. Louis XVI French

Art. 1370



Art. 1370SB
(photo ref. / rif. foto)

Soleil single buttoned headboard
end XVIII Sec. Louis XVI French
Testata letto Soleil capitonné singola
fine XVIII Sec. Luigi XVI Francese



Decoro
G079 Oro leggero

P	S
OVERALL DIMENSIONS WITH SOMMIER / INGOMBRO MASSIMO CON SOMMIER	
108 x 210 x h 162 cm	128 x 210 x h 162 cm
OVERALL DIMENSIONS WITH BED FRAME (ART. 3001/3002) / INGOMBRO MASSIMO CON GIROLETTO (ART. 3001/3002)	
110 x 213 x h 162 cm	130 x 213 x h 162 cm
MATRESS SIZE (NOT PROVIDED) / MATERASSO ABBINATO (NON FORNITO)	
100 x 200 x h 25 cm	120 x 200 x h 25 cm

HEADBOARD PADDING / IMBOTTITURA TESTATA		
PLAIN / LISCIA	B (BUTTONED / CAPITONNÉ)	BPE (BUTTONED LEATHER / CAPITONNÉ PELLE)
SOMMIER UPHOLSTERY / IMBOTTITURA SOMMIER		
FABRIC / TESSUTO		PE (LEATHER / PELLE)

Napoletana

Half XVIII C. Neapolitan

Art. 1371



Art. 1371S
(photo ref. / rif. foto)

Neapolitan single headboard
with sommier
and wooden legs Art. 3004
half XVIII Sec. Neapolitan
Testata letto Napoletana singola
con sommier e piedini Art. 3004
metà XVIII Sec. Napoletano

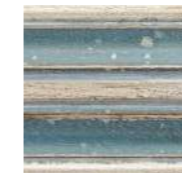

Decoro
G018 Zaffiro

P	S
OVERALL DIMENSIONS WITH SOMMIER / INGOMBRO MASSIMO CON SOMMIER	
120 x 210 x h 163 cm	140 x 210 x h 163 cm
OVERALL DIMENSIONS WITH BED FRAME (ART. 3001/3002) / INGOMBRO MASSIMO CON GIROLETTO (ART. 3001/3002)	
120 x 213 x h 163 cm	140 x 213 x h 163 cm
MATRESS SIZE (NOT PROVIDED) / MATERASSO ABBINATO (NON FORNITO)	
100 x 200 x h 25 cm	120 x 200 x h 25 cm

HEADBOARD PADDING / IMBOTTITURA TESTATA		
PLAIN / LISCIA	B (BUTTONED / CAPITONNÉ)	BPE (BUTTONED LEATHER / CAPITONNÉ PELLE)
SOMMIER UPHOLSTERY / IMBOTTITURA SOMMIER		
FABRIC / TESSUTO		PE (LEATHER / PELLE)

CHESTS OF DRAWERS AND NIGHT TABLES CASSETTONI E COMODINI

The chests of drawers and night tables are made of carved solid wood and are supplied with a wooden top; some models have a marble top and a carved handle or bronze handle option.

The drawers are made with wooden runners; on request, and only on some models, it is possible to request metal runners (separately priced).

I cassettoni e comodini sono realizzati in legno massello intagliato sono forniti con piano in legno; per alcuni modelli è prevista l'opzione con piano in marmo e l'opzione maniglia intagliata o maniglia in bronzo.

I cassetti sono realizzati con guide in legno, su richiesta, e solo su alcuni modelli, è possibile richiedere le guide metalliche (quotazione a parte).

CHESTS OF DRAWERS_CASSETTONI

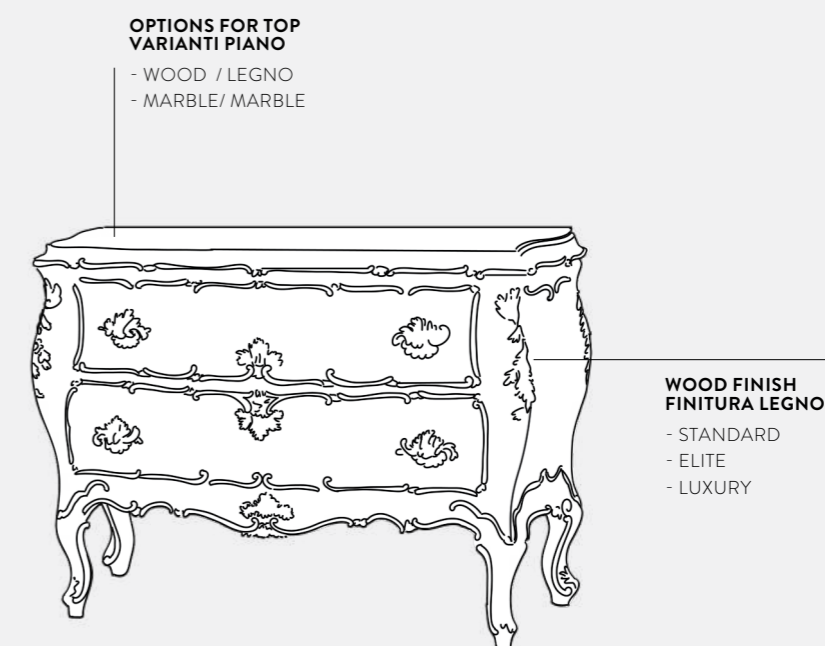

NIGHT TABLES_COMODINI

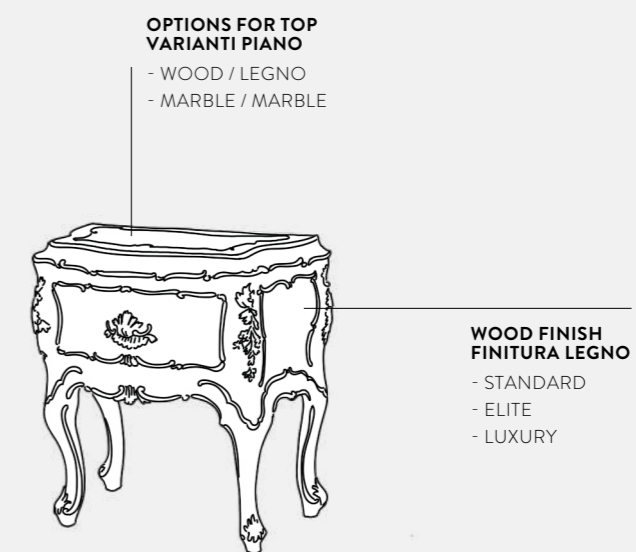

503PL

Half XVIII C. Louis XV French

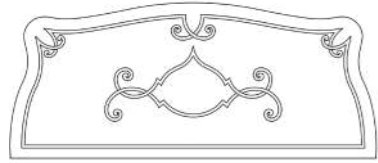

Engraved wooden top_incisione piano legno

Art. 503PL
(photo ref. / foto ref.)

Chest of drawers with ramage
half XVIII C. Louis XV French
Cassettone ramage
metà XVIII Sec. Luigi XV Francese

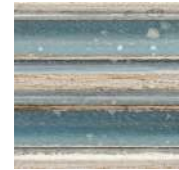

Decoro
G018 Zaffiro

DIMENSIONS / DIMENSIONI			
130 x 56 x h 90 cm			
OPTIONS FOR TOP / VARIANTI PIANO			
WOOD / LEGNO	MARBLE / MARMO		
	STANDARD	ELITE A	ELITE B
✓	-	-	-

533PL

Half XVIII C. Louis XV French



Engraved wooden top_incisione piano legno

Art. 533PL
(photo ref. / foto ref.)

Night table with ramage
half XVIII C. Louis XV French
Comodino ramage
metà XVIII Sec. Luigi XV Francese

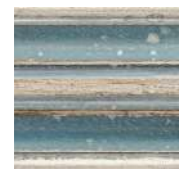

Decoro
G018 Zaffiro

DIMENSIONS / DIMENSIONI			
61 x 37 x h 66 cm			
OPTIONS FOR TOP / VARIANTI PIANO			
WOOD / LEGNO	MARBLE / MARMO		
	STANDARD	ELITE A	ELITE B
✓	-	-	-

1378

Louis XV Italian

Art. 1378
(photo ref. / foto ref.)

Chest of drawers with fretwork
and carved handle
Louis XV Italian
Cassettone con traforo
e maniglia intagliata
Luigi XV Italiano



Decoro
G094 Prestige



Bronze handle_maniglia bronzo



DIMENSIONS / DIMENSIONI			
138 x 56 x h 90,5 cm			
OPTIONS FOR HANDLES / VARIANTI MANIGLIA			
CARVED WOOD / INTAGLIE		BRONZE / BRONZO	
1378		1378MB	
OPTIONS FOR TOP / VARIANTI PIANO			
WOOD / LEGNO	MARBLE / MARMO		
	STANDARD	ELITE A	ELITE B
✓	✓	✓	✓

1377

Louis XV Italian

Art. 1377
(photo ref. / foto ref.)

Night table with fretwork
and carved handle
Louis XV Italian
Comodino con traforo
e maniglia intagliata
Luigi XV Italiano

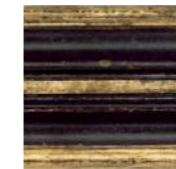

Decoro
G094 Prestige



Bronze handle_maniglia bronzo



DIMENSIONS / DIMENSIONI			
80 x 44 x h 69,5 cm			
OPTIONS FOR HANDLES / VARIANTI MANIGLIA			
CARVED WOOD / INTAGLIE		BRONZE / BRONZO	
1377		1377MB	
OPTIONS FOR TOP / VARIANTI PIANO			
WOOD / LEGNO	MARBLE / MARMO		
	STANDARD	ELITE A	ELITE B
✓	✓	✓	✓

1153

XVIII C. Tuscan Pitti



Art. 1153
(photo ref. / foto ref.)

Pitti chest of drawers
XVIII C. Tuscan
Cassettone Pitti
XVIII Sec. Toscano



Decoro
G012 Greige

Bronze handle_maniglia bronzo

DIMENSIONS / DIMENSIONI			
138 x 62 x h 90 cm			
OPTIONS FOR HANDLES / VARIANTI MANIGLIA			
CARVED WOOD / INTAGLIATE		BRONZE / BRONZO	
1158		1158MB	
OPTIONS FOR TOP / VARIANTI PIANO			
WOOD / LEGNO		MARBLE / MARMO	
✓		STANDARD	ELITE A
		-	-

1316

XVIII C. Tuscan



Art. 1316
(photo ref. / foto ref.)

Pitti night table
XVIII C. Tuscan
Comodino Pitti
XVIII Sec. Toscano



Decoro
G012 Greige

Bronze handle_maniglia bronzo

DIMENSIONS / DIMENSIONI			
81 x 43 x h 70 cm			
OPTIONS FOR HANDLES / VARIANTI MANIGLIA			
CARVED WOOD / INTAGLIATE		BRONZE / BRONZO	
1316		1316MB	
OPTIONS FOR TOP / VARIANTI PIANO			
WOOD / LEGNO		MARBLE / MARMO	
✓		STANDARD	ELITE A
		-	-

1344

End XVIII C. Venetian



Art. 1344
(photo ref. / foto ref.)

Chest of 3 drawers
end XVIII C. Venetian
Cassettone 3 cassetti
fine XVIII sec. Veneziano



Decoro
G079 Oro leggero

DIMENSIONS / DIMENSIONI			
148 x 55 x h 90 cm			
OPTIONS FOR TOP / VARIANTI PIANO			
WOOD / LEGNO		MARBLE / MARMO	
✓		STANDARD	ELITE A
		✓	✓

1354

End XVIII C. Venetian



Art. 1354
(photo ref. / foto ref.)

Night table 2 drawers
end XVIII C. Venetian
Comodino 2 cassetti
fine XVIII sec. Veneziano



Decoro
G079 Oro leggero

DIMENSIONS / DIMENSIONI			
82 x 46 x h70 cm			
OPTIONS FOR TOP / VARIANTI PIANO			
WOOD / LEGNO		MARBLE / MARMO	
✓		STANDARD	ELITE A
		✓	✓

1279

Half XVIII C. Roman



Art. 1279
(photo ref. / foto ref.)

Borghese chest of drawers
half XVIII C. Roman
Cassettone borghese
metà XVIII Sec. Romano

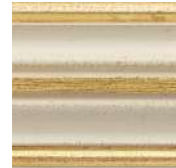

Decoro
G003 Magnolia

DIMENSIONS / DIMENSIONI			
138 x 57 x h 90 cm			
OPTIONS FOR TOP / VARIANTI PIANO			
WOOD / LEGNO	MARBLE / MARMO		
✓	STANDARD	ELITE A	ELITE B
	-	-	-

1280

Half XVIII C. Roman



Art. 1280
(photo ref. / foto ref.)

Borghese night table
half XVIII C. Roman
Comodino borghese
metà XVIII Sec. Romano

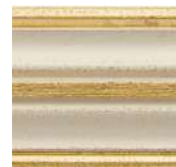

Decoro
G003 Magnolia

DIMENSIONS / DIMENSIONI			
81 x 46 x h 70 cm			
OPTIONS FOR TOP / VARIANTI PIANO			
WOOD / LEGNO	MARBLE / MARMO		
✓	STANDARD	ELITE A	ELITE B
	-	-	-



1322

XVIII C. Tuscan



Art. 1322
(photo ref. / foto ref.)

Chest of drawers Fiorellacci
XVIII C. Tuscan
Cassettone Fiorellacci
XVIII Sec. Toscano



Decoro
G079 Oro Leggero

DIMENSIONS / DIMENSIONI			
138 x 56 x h 90 cm			
OPTIONS FOR TOP / VARIANTI PIANO			
WOOD / LEGNO	MARBLE / MARMO		
	STANDARD	ELITE A	ELITE B
✓	-	-	-

1319

XVIII C. Tuscan



Art. 1319
(photo ref. / foto ref.)

Night table Fiorellacci
XVIII C. Tuscan
Comodino Fiorellacci
XVIII Sec. Toscano



Decoro
G079 Oro Leggero

DIMENSIONS / DIMENSIONI			
81 x 46 x h 70 cm			
OPTIONS FOR TOP / VARIANTI PIANO			
WOOD / LEGNO	MARBLE / MARMO		
	STANDARD	ELITE A	ELITE B
✓	-	-	-

525PL

End XVIII C. Neoclassical

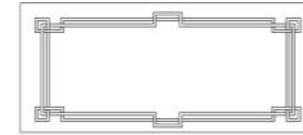

Engraved wooden top_incisione piano legno

Art. 525PL
(photo ref. / foto ref.)

Chest of drawers with laurel carving
end XVIII C. Neoclassical
Cassettone con intreccio alloro
fine XVIII Sec. Neoclassico

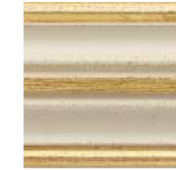

Decoro
G003 Magnolia

684PL

End XVIII C. Neoclassical

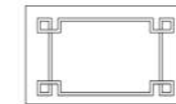

Engraved wooden top_incisione piano legno

Art. 684PL
(photo ref. / foto ref.)

Night table with laurel carving
end XVIII C. Neoclassical
Comodino con intreccio di alloro
fine XVIII Sec. Neoclassico



Decoro
G003 Magnolia



DIMENSIONS / DIMENSIONI			
125 x 55 x h 90 cm			
OPTIONS FOR TOP / VARIANTI PIANO			
WOOD / LEGNO	MARBLE / MARMO		
	STANDARD	ELITE A	ELITE B
✓	✓	✓	✓



DIMENSIONS / DIMENSIONI			
63 x 39 x h 66 cm			
OPTIONS FOR TOP / VARIANTI PIANO			
WOOD / LEGNO	MARBLE / MARMO		
	STANDARD	ELITE A	ELITE B
✓	✓	✓	✓



1407

Half XVIII C. French

Art. 1407
(photo ref. / foto ref.)

Chest of 2 drawers
half XVIII C. French
Cassettone 2 cassetti
metà XVIII Sec. Francese



Decoro
G096 Bianco Fiorentino



DIMENSIONS / DIMENSIONI			
138 x 60 x h 92 cm			
OPTIONS FOR TOP / VARIANTI PIANO			
WOOD / LEGNO	MARBLE / MARMO		
	STANDARD	ELITE A	ELITE B
✓	✓	✓	✓

1412

Half XVIII C. French

Art. 1412
(photo ref. / foto ref.)

Night table 2 drawers
half XVIII C. French
Comodino 2 cassetti
metà XVIII Sec. Francese



Decoro
G096 Bianco Fiorentino



DIMENSIONS / DIMENSIONI			
81 x 44 x h 73 cm			
OPTIONS FOR TOP / VARIANTI PIANO			
WOOD / LEGNO	MARBLE / MARMO		
	STANDARD	ELITE A	ELITE B
✓	✓	✓	✓

1409

Neoclassical French



Art. 1409
(photo ref. / foto ref.)

Chest of 3 drawers
Neoclassical French
Cassettone 3 cassetti
Neoclassico Francese



Decoro
G110 Barocco e Argento

DIMENSIONS / DIMENSIONI			
138 x 60 x h 94 cm			
OPTIONS FOR TOP / VARIANTI PIANO			
WOOD / LEGNO	MARBLE / MARMO		
	STANDARD	ELITE A	ELITE B
✓	✓	✓	✓

1435

XVIII C. French



Art. 1435
(photo ref. / foto ref.)

Chest of drawers with bronze handles
XVIII C. French
Cassettone con maniglie in bronzo
XVII Sec. Francese



Decoro
G095 Antico Veneziano

DIMENSIONS / DIMENSIONI			
138 x 55 x h 90 cm			
OPTIONS FOR TOP / VARIANTI PIANO			
WOOD / LEGNO	MARBLE / MARMO		
	STANDARD	ELITE A	ELITE B
✓	✓	✓	✓

1410

Neoclassical French



Art. 1410
(photo ref. / foto ref.)

Night table 2 drawers
Neoclassical French
Comodino 2 cassetti
Neoclassico Francese



Decoro
G110 Barocco e Argento

DIMENSIONS / DIMENSIONI			
84 x 44 x h 71 cm			
OPTIONS FOR TOP / VARIANTI PIANO			
WOOD / LEGNO	MARBLE / MARMO		
	STANDARD	ELITE A	ELITE B
✓	✓	✓	✓

1436

XVIII C. French



Art. 1436
(photo ref. / foto ref.)

Night table with bronze handles
XVIII C. French
Comodino 2 cassetti con maniglie in bronzo
XVII Sec. Francese



Decoro
G095 Antico Veneziano

DIMENSIONS / DIMENSIONI			
83 x 45 x h 69 cm			
OPTIONS FOR TOP / VARIANTI PIANO			
WOOD / LEGNO	MARBLE / MARMO		
	STANDARD	ELITE A	ELITE B
✓	✓	✓	✓

1263

XVIII C. Venetian



Art. 1263
(photo ref. / foto ref.)

Laguna double chest of drawers
XVIII C. Venetian
Cassettone Laguna doppio
XVIII Sec. Veneziano



Decoro
A004 Gardenia

DIMENSIONS / DIMENSIONI			
181 x 61 x h 90 cm			
OPTIONS FOR TOP / VARIANTI PIANO			
WOOD / LEGNO	MARBLE / MARMO		
	STANDARD	ELITE A	ELITE B

✓	-	-	-
---	---	---	---

1219

XVIII C. Venetian



Art. 1219
(photo ref. / foto ref.)

Laguna chest of drawers
XVIII C. Venetian
Cassettone Laguna
XVIII Sec. Veneziano



Decoro
G095 Antico Veneziano

DIMENSIONS / DIMENSIONI			
127 x 55 x h 90 cm			
OPTIONS FOR TOP / VARIANTI PIANO			
WOOD / LEGNO	MARBLE / MARMO		
	STANDARD	ELITE A	ELITE B

✓	-	-	-
---	---	---	---

1227

XVIII C. Venetian



Art. 1227
(photo ref. / foto ref.)

Laguna night table
XVIII C. Venetian
Comodino Laguna
XVIII Sec. Veneziano



Decoro
A004 Gardenia

DIMENSIONS / DIMENSIONI			
66 x 37 x h 66 cm			
OPTIONS FOR TOP / VARIANTI PIANO			
WOOD / LEGNO	MARBLE / MARMO		
	STANDARD	ELITE A	ELITE B

✓	-	-	-
---	---	---	---

1072S

Half XVII C. Louis XIV



Art. 1072S
(photo ref. / foto ref.)

Night table with drawer
half XVII C. Louis XIV
Tavolino lato letto con cassetto
metà XVII Sec. Luigi XIV



Decoro
G079 Oro Leggero

DIMENSIONS / DIMENSIONI			
77 x 50 x h 67 cm			
OPTIONS FOR TOP / VARIANTI PIANO			
WOOD / LEGNO	MARBLE / MARMO		
	STANDARD	ELITE A	ELITE B

✓	✓	✓	✓
---	---	---	---

1437

Luigi XV Italian

Art. 1437
(photo ref. / foto ref.)

5 drawers unit
with carved handles
Luigi XV Italian
Cassettiera 5 cassetti
con maniglie intagliate
Luigi XV Italiano



Decoro
G079 Oro Leggero



Bronze handle_maniglia bronzo

DIMENSIONS / DIMENSIONI			
80 x 44 x h 125 cm			
OPTIONS FOR HANDLES / VARIANTI MANIGLIA			
CARVED / INTAGLIATE		BRONZE / BRONZO	
1437		1437MB	
OPTIONS FOR TOP / VARIANTI PIANO			
WOOD / LEGNO		MARBLE / MARMO	
✓		STANDARD	ELITE A
		✓	✓
			ELITE B
			✓

1442

Neoclassical French

Art. 1442
(photo ref. / foto ref.)

6 drawers unit
Neoclassical Francese
Cassettiera 6 cassetti
Neoclassico Francese



Decoro
G110 Barocco e Argento



DIMENSIONS / DIMENSIONI			
84 x 44 x h 148 cm			
OPTIONS FOR TOP / VARIANTI PIANO			
WOOD / LEGNO		MARBLE / MARMO	
✓		STANDARD	ELITE A
		✓	✓
			ELITE B
			✓

1398

End XVIII C. Tuscan

1398
(photo ref. / foto ref.)

Wardrobe 2 doors
end XVIII C. Tuscan
Armadio 2 ante
fine XVIII Sec. Toscano



Decoro
G017 Ciliegio e Argento



DIMENSIONS / DIMENSIONI	
143 x 63 x h 224 cm	



DESKS SCRIVANIE

— DESKS
Scrivanie

pag 342



DESKS SCRIVANIE

The desks are made of carved solid wood and are supplied with a tabletop in wood or, where possible, in leather (LE). Each item can be supplied with a protective top in extra-clear glass to be quoted upon request.

Le scrivanie sono realizzate in legno massello intagliato e sono fornite con piano in legno o, dove possibile, con piano in pelle (lettere LE). Ogni articolo può essere corredato con piano protettivo in vetro extra-chiaro da quotare su richiesta.



**WOOD FINISH
FINITURA LEGNO**
- STANDARD
- ELITE
- LUXURY

1058S

End XVIII C. Neoclassical Italian



Art. 1058SLE
(photo ref. / foto ref.)

Desk with leather top
pull-out shelves 45 cms
and 3 drawers
end XVIII C. Neoclassical Italian
Scrivanìa con piano in pelle
completa di tiretti 45 cm
e 3 cassetti
fine XVIII Sec. Neoclassico Italiano



Decoro
G079 Oro Leggero

DIMENSIONS / DIMENSIONI	
173 x 106 x h 80 cm	
OPTIONS FOR TOP / VARIANTI PIANO	
WOOD / LEGNO	LEATHER / PELLE
1058S	1058SLE



1359

Half XVIII C. Louis XV French



Art. 1359LE
(photo ref. / foto ref.)

Desk with 3 drawers and leather top half XVIII C. Louis XV French
Scrivania con tre cassetti e piano in pelle metà XVIII Sec. Luigi XV Francese

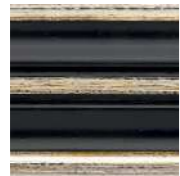

Decoro
G098 Noir e Argento

DIMENSIONS / DIMENSIONI	
180 x 98 x h 79 cm	
OPTIONS FOR TOP / VARIANTI PIANO	
WOOD / LEGNO	LEATHER / PELLE
1359	1359LE

1047

half XVIII C. Louis XV French

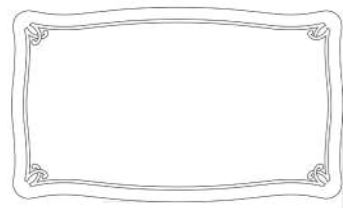

Engraved wooden top_incisione piano legno

Art. 1047
(photo ref. / foto ref.)

Desk ramage with 3 drawers half XVIII C. Louis XV French
Scrivania 3 cassetti ramage metà XVIII Sec. Luigi XV Francese



Decoro
G043 Ebony



DIMENSIONS / DIMENSIONI	
136 x 80 x h 76 cm	

1171

End XVIII C. Louis XVI

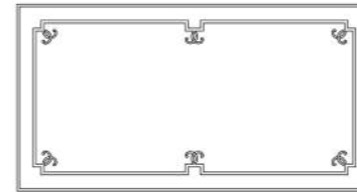

Engraved wooden top_incisione piano legno

Art. 1171
(photo ref. / foto ref.)

Small desk with 2 drawers end XVIII C. Louis XVI
Scrittoio con 2 cassetti fine XVIII Sec. Luigi XVI



Decoro
G043 Ebony

1452

Neoclassical

Art. 1452LE
(photo ref. / foto ref.)

Neoclassical writing desk with leather top and 1 drawer
Scrivania Neoclassico con piano in pelle e 1 cassetto



Decoro
G079 Oro Leggero



DIMENSIONS / DIMENSIONI	
113 x 59 x h 74 cm	

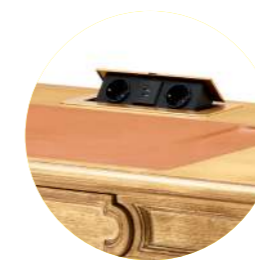

Equipment of hidden sockets and wireless charger on request
Su richiesta prese a scomparsa e caricatore wireless

DIMENSIONS / DIMENSIONI	
113 x 60 x h 78 cm	
OPTIONS FOR TOP / VARIANTI PIANO	
WOOD / LEGNO	LEATHER / PELLE
1452	1452LE

1277

XVIII C. Venetian



Art. 1277
(photo ref. / foto ref.)

Laguna vanity 2 drawers
XVIII C. Venetian
Scrigno Laguna 2 cassetti
XVIII Sec. Veneziano



Decoro
G012 Greige

DIMENSIONS / DIMENSIONI	
124 x 70 x h 74 cm	

1301

half XVIII C. Roman



Art. 1301
(photo ref. / foto ref.)

Borghese vanity table 2 drawers
half XVIII C. Roman
Scrigno Borghese 2 cassetti
piano sagomato
metà XVIII Sec. Romano



Decoro
G008 Trianon

DIMENSIONS / DIMENSIONI	
124 x 72 x h 75 cm	

1396

End XVIII C. Tuscan



Art. 1396A
(photo ref. / foto ref.)

Vanity table 4 drawers
and flaptop
end XVIII C. Tuscan
Vanity 4 cassetti
e ribalta
fine XVIII Sec. Toscano



Decoro
G017 Ciliegio e Argento

DIMENSIONS / DIMENSIONI	
159 x 61 x h 80 cm	
OPTIONS FOR TOP / VARIANTI PIANO	
WITH FLAP TOP AND MIRROR - 4 DRAWERS / CON RIBALTA - 4 CASSETTI	WOODEN TOP - 5 DRAWERS / SENZA RIBALTA - 5 CASSETTI
1396A	1396

1325

XVIII C. Tuscan



Art. 1325
(photo ref. / foto ref.)

Fiorellacci vanity 4 drawers
XVIII C. Tuscan
Scrivanina Fiorellacci 4 cassetti
XVIII Sec. Toscano

1323 Mirror frame_ Specchio
1328 Bench_ Pouff



Decoro
G011 Vanwood

DIMENSIONS / DIMENSIONI	
139 x 64 x h 75 cm	

BOOKCASES LIBRERIE

— BOOKCASES
Librerie

pag 352



BOOKCASES LIBRERIE

The bookcases in the collection are made of carved solid wood and are available in all finish variants: **Standard, Elite, Luxury**. The interiors of the bookcases are made in a **Rovere sbiancato** finish (code G067) or in a colour matching the exterior finish of our choice. It is possible to request a different finish, which will be evaluated in terms of feasibility and price.

Le librerie della collezione sono realizzate in legno massello intagliato e sono disponibili in tutte le varianti di finiture: **Standard, Elite, Luxury**. Gli interni delle librerie sono realizzati in finitura **Rovere sbiancato** (cod. G067) o in tinta abbinata alla finitura esterna a nostra scelta. È possibile richiedere una finitura diversa che sarà valutata in termini di fattibilità e di preventivo.

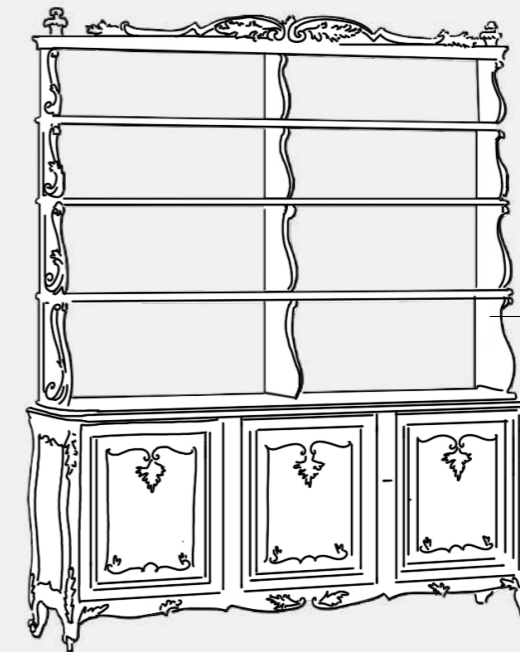

**WOOD FINISH
FINITURA LEGNO**
- STANDARD
- ELITE
- LUXURY

1414

Beg. XVIII C. Louis XIV Italian



Art. 1414
(photo ref. / foto ref.)

Bookcase with ornament
beg. XVIII C. Louis XIV Italian
Libreria con frontone
XVIII Sec. Toscano Luigi XIV Italiano



Decoro
G067 Rovere Sbiancato

DIMENSIONS / DIMENSIONI

239 x 50 x h 273 cm



1249

XVIII C. Tuscan



Art. 1249
(photo ref. / foto ref.)

Cupboard with shelves
XVIII C. Tuscan
Libreria a giorno con sportelli
XVIII Sec. Toscano



Decoro
G011 Vanwood

DIMENSIONS / DIMENSIONI

184 x 37 x h 215 cm

1239

XVIII C. Tuscan



Art. 1239
(photo ref. / foto ref.)

Bookcase
XVIII C. Tuscan
Libreria a giorno
XVIII Sec. Toscano

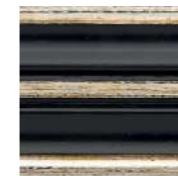

Decoro
G074 Ebony e Argento

DIMENSIONS / DIMENSIONI

163 x 35 x h 180 cm

1339

Half XVII C. Louis XIV Italian



Art. 1339
(photo ref. / foto ref.)

Bookcase
half XVII C. Louis XIV Italian
Libreria con cornice
metà XVII Sec. Luigi XIV Italiano



Decoro
G043 Ebony



Interior
G067
Rovere sbiancato

DIMENSIONS / DIMENSIONI

156 x 42 x h 210 cm

1433

XVII C. Tuscan



Art. 1433
(photo ref. / foto ref.)

Bookcase
XVII C. Tuscan
Libreria
XVII Sec. Tuscan



Decoro
G022 Argento Pitti



Interior
G067
Rovere sbiancato

DIMENSIONS / DIMENSIONI

149 x 38 x h 214 cm

1269

XVIII C. Tuscan Leopolda



Art. 1269
(photo ref. / foto ref.)

Low bookcase
XVIII C. Tuscan Leopolda
Mobile libreria basso
XVIII Sec. Toscano Leopolda



Decoro
G027 Colonial

DIMENSIONS / DIMENSIONI

184 x 37 x h 78 cm





ACCESSORIES ACCESSORI

— ACCESSORIES Accessori	pag 364
— ORNAMENTS Ornamenti	pag 366
— FIREPLACES Camini	pag 368
— PEDESTALS Piedistalli	pag 372
— WALL SHELVES Mensole	pag 377
— SCULPTURES Sculture	pag 383
— BAS-RELIEF Bassorilievi	pag 390



ACCESSORIES

ACCESSORI

The collection's accessories are subdivided into:

Ornaments: made of carved solid wood available in all finish variants.

Fireplaces: decorative surrounds made of solid wood to be used as a decoration for fireplace openings, not open-flame, are available in all finish variants **Standard, Elite, Luxury** the interior can be supplied decorated with mirrors, antique effect or plain and or with wooden legs.

Plinth stands: made of carved solid wood available in all finish variants: **Standard, Elite, Luxury.**

Shelves: made of carved solid wood available in all finish variants: **Standard, Elite, Luxury.**

Sculptures: made of carved solid wood available in all finish variants: **Standard, Elite, Luxury.**

Bas-reliefs: made of plaster or plaster mix in a variety of subjects. Some subjects fit into the collection's frames, instead of the mirror, decorated in all finish variations.

I complementi della collezione si suddividono in:

Ornamenti: realizzati in legno massello intagliato disponibili in tutte le varianti finitura.

Camini: cornici decorative in legno massello da utilizzare come decorazione per bocche di camino, non a fiamma libera, sono disponibili in tutte le varianti di finiture: **Standard, Elite, Luxury** l'interno può essere fornito con specchi, anticati o lisci e o con ceppi in legno.

Piedistalli: realizzati in legno massello intagliato disponibili in tutte le varianti di finiture: **Standard, Elite, Luxury.**

Mensole: realizzate in legno massello intagliato disponibili in tutte le varianti di finiture: **Standard, Elite, Luxury.**

Sculture: realizzate in legno massello intagliato disponibili in tutte le varianti di finiture: **Standard, Elite, Luxury.**

Bassorilievi: realizzati in gesso o mescola di gesso a vari soggetti. Alcuni soggetti si adattano a cornici della collezione, al posto dello specchio, decorate in tutte le varianti di finitura.

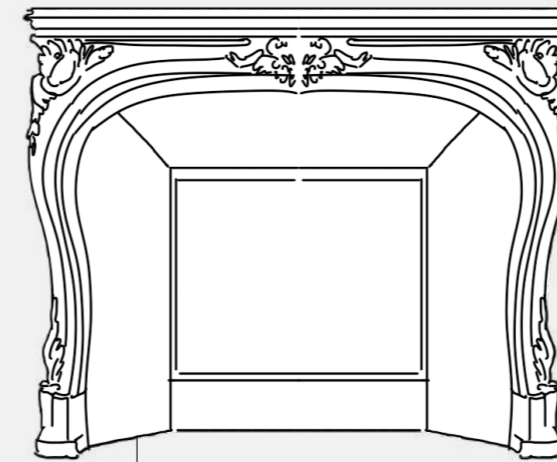

**WOOD FINISH
FINITURA LEGNO**
- STANDARD
- ELITE
- LUXURY

**DECORATION FOR INTERIOR
VARIANTI INTERNO**
- MIRROR / SPECCHIO
- WOOD / LEGNO
- WOOD AND MIRROR / LEGNO E SPECCHIO



**WOOD FINISH
FINITURA LEGNO**
- STANDARD
- ELITE
- LUXURY



**WOOD FINISH
FINITURA LEGNO**
- STANDARD
- ELITE
- LUXURY

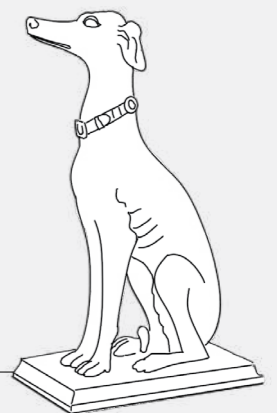

**WOOD FINISH
FINITURA LEGNO**
- STANDARD
- ELITE
- LUXURY



**WOOD FINISH
FINITURA LEGNO**
- STANDARD
- ELITE
- LUXURY

213

Beg XVIII C.

Art. 213
(photo ref. / foto ref.)

Overdoor with acanthus leaves
beg. XVIII C.
Sovrapporta con acanto
inizio XVIII Sec.

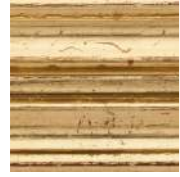

Decoro
A039 Oro Versailles



DIMENSIONS / DIMENSIONI

72 x h 22 cm

398

End XVIII C. Neoclassical

Art. 398
(photo ref. / foto ref.)

Overdoor with laurel
end XVIII C. Neoclassical
Sovrapporta con alloro
fine XVIII Sec. Neoclassico



Decoro
A023 Argento



DIMENSIONS / DIMENSIONI

78 x h 21 cm

399

End XVIII C. Louis XVI French

Art. 399
(photo ref. / foto ref.)

Overdoor with arch and arrows
end XVIII C. Louis XVI French
Sovrapporta con arco e frecce
fine XVIII Sec. Luigi XVI Francese



Decoro
A041 Impero



DIMENSIONS / DIMENSIONI

80 x h 24 cm

810S

End XVIII C. Neoclassical French

Art. 810S
(photo ref. / foto ref.)

Trophy ornament
end XVIII C. Neoclassical French
Ornamento trofeo grande
fine XVIII Sec. Neoclassico Francese



Decoro
G009 Blanc



DIMENSIONS / DIMENSIONI

49 x h 116 cm

315

Reading desk

Art. 315
(photo ref. / foto ref.)

Reading desk
Leggio



Decoro
A025 Argento Antico



DIMENSIONS / DIMENSIONI

48 x 33 x h 19 cm



1297

End XVIII C. Neoclassico

Art. 1297 - INT S
(photo ref. / foto ref.)

Wooden frame for
end XVIII C. Neoclassical
Cornice in legno per camino
fine XVIII Sec. Neoclassico



Decoro
A023 Argento

343

Beg. XVIII C. Regency

Art. 343 - INT L
(photo ref. / foto ref.)

Wooden frame for fireplace
beg. XVIII C. Regency
Cornice in legno per camino
inizio XVIII Sec. Reggenza



Decoro
G043 Ebony



DIMENSIONS / DIMENSIONI

155 x 23 x h 126 cm

DECORATION FOR INTERIOR / INTERNI DISPONIBILI

MIRROR / SPECCHIO (INT S)		MIRROR AND WOODEN LOGS / SPECCHIO E CIOCCHI LEGNO (INT L)	
PLAIN / LISCIO	ANTIQUE / ANTICATO	PLAIN / LISCIO	ANTIQUE / ANTICATO
✓	✓	✓	✓



DIMENSIONS / DIMENSIONI

145 x 28 x h 120 cm

DECORATION FOR INTERIOR / INTERNI DISPONIBILI

MIRROR / SPECCHIO (INT S)		MIRROR AND WOODEN LOGS / SPECCHIO E CIOCCHI LEGNO (INT L)	
PLAIN / LISCIO	ANTIQUE / ANTICATO	PLAIN / LISCIO	ANTIQUE / ANTICATO
✓	✓	✓	✓

1363

Transitional French

Art. 1363 - INT LK
(photo ref. / foto ref.)

Wooden frame for fireplace
Transitional French
Cornice in legno per camino
Transizione Francese

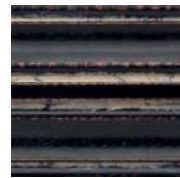

Decoro
G087 Nero Fiammingo



DIMENSIONS / DIMENSIONI			
153 x 40 x h 122 cm			
DECORATION FOR INTERIOR / INTERNI DISPONIBILI			
MIRROR / SPECCHIO (INT SK)		MIRROR AND WOODEN LOGS / SPECCHIO E CIOCCHI LEGNO (INT LK)	
PLAIN / LISCIO	ANTIQUÉ / ANTICATO	PLAIN / LISCIO	ANTIQUÉ / ANTICATO
✓	✓	✓	✓

1364

Neoclassical

Art. 1364 INT SK
(photo ref. / foto ref.)

Wooden frame trois fleurs
for fireplace
Neoclassical
Cornice in legno
per camino trois fleurs
Neoclassico



Decoro
G008 Trianon



DIMENSIONS / DIMENSIONI			
153 x 49 x h 121 cm			
DECORATION FOR INTERIOR / INTERNI DISPONIBILI			
MIRROR / SPECCHIO (INT SK)		MIRROR AND WOODEN LOGS / SPECCHIO E CIOCCHI LEGNO (INT LK)	
PLAIN / LISCIO	ANTIQUÉ / ANTICATO	PLAIN / LISCIO	ANTIQUÉ / ANTICATO
✓	✓	✓	✓



912AC

Half XVIII C.

Art. 912AC
(photo ref. / foto ref.)

Coat Hanger
half XVIII C.
Attaccapanni
metà XVIII Sec.

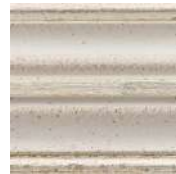

Decoro
G017 Ciliegio e Argento



DIMENSIONS / DIMENSIONI

52 x 52 x h 184 cm

1101

Half XVIII C. Roman

Art. 1101
(photo ref. / foto ref.)

Pedestal
half XVIII C. Roman
Piedistallo
metà XVIII Sec. Romano



Decoro
G032 Pickled Pine Oro



DIMENSIONS / DIMENSIONI

Ø 39 x h 128 cm

680

Belle Epoque French

Art. 680
(photo ref. / foto ref.)

Pedestal
Belle Epoque French
Piedistallo
Belle Epoque Francese



Decoro
G006 Provence



DIMENSIONS / DIMENSIONI

Ø 34 x h 122 cm

1035

Half XVII C. Louis XIV

Art. 1035
(photo ref. / foto ref.)

Pedestal
half XVII C. Louis XIV
Piedistallo
metà XVII Sec. Luigi XIV



Decoro
G007 Canova



DIMENSIONS / DIMENSIONI

33 x 33 x h 128 cm

1062

End XVIII C. Neoclassical Italian



Art. 1062
(photo ref. / foto ref.)

Vase and column
end XVIII C. Neoclassical Italian
Vaso e colonna
fine XVIII Sec. Neoclassico Italiano

1062SB Vase / Vaso
1062C Column / Colonna



Decoro
G096 Bianco Fiorentino

DIMENSIONS / DIMENSIONI	
1062 complete / completo	58 x 40 x h 159 cm
1062SB vase / vaso	58 x 40 x h 59 cm
1062C column / colonna	37 x 37 x h 100 cm

531

XVIII C. Farnese



Art. 531
(photo ref. / foto ref.)

Vase with column
XVIII C. Farnese
Vaso con colonna
XVIII C. Farnese

531SB Vase / Vaso
531C Column / Colonna



Decoro
G008 Trianon

DIMENSIONS / DIMENSIONI	
531 complete / completo	Ø 55 x h 157 cm
531SB vase / vaso	Ø 55 x h 62 cm
531C column / colonna	39 x 39 x h 95 cm



249

XVIII C. Venetian



Art. 249
(photo ref. / foto ref.)

Blackmoor
XVIII C. Venetian
Moretto con vassoio
XVIII Sec. Veneziano



Decoro
G010 Florence

DIMENSIONS / DIMENSIONI

38 x 50 x h 126 cm

452

Fine XVIII Sec. Luigi XVI Francese

Art. 452
(photo ref. / foto ref.)

Wall shelf with ribbon
end XVIII C. Louis XVI French
Mensola con fiocco
fine XVIII Sec. Luigi XVI Francese



Decoro
G010 Florence

408

Plumages

Art. 408
(photo ref. / foto ref.)

Wall shelf with 3 plumages
Mensola a 3 piume



Decoro
G009 Blanc

9

Beg. XVIII C. Venetian

Art. 9
(photo ref. / foto ref.)

Wall shelf
beg. XVIII C. Venetian
Mensola
inizio XVIII Sec. Veneziano



Decoro
G022 Argento Pitti



DIMENSIONS / DIMENSIONI

54 x 26 x h 34 cm



DIMENSIONS / DIMENSIONI

42 x 21 x h 36 cm



DIMENSIONS / DIMENSIONI

70 x 37 x h 55 cm

1032

XVIII C. Venetian

Art. 1032
(photo ref. / foto ref.)

Wall shelf
XVIII C. Venetian
Mensola
XVIII Sec. Veneziano

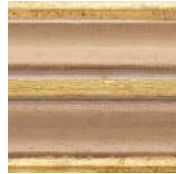

Decoro
G032 Pickled Pine Oro



ARTICLE / ARTICOLO	DIMENSIONS / DIMENSIONI
1032	60 x 29 x h 51 cm
1032P	36 x 19 x h 32 cm

443

End XVIII C. Neoclassical

Art. 443
(photo ref. / foto ref.)

Wall shelf with stylized acanthus leaf end
XVIII C. Neoclassical
Mensola con foglia d'acanto stilizzata
fine XVIII Sec. Neoclassico



Decoro
G043 Ebony



DIMENSIONS / DIMENSIONI
41 x 28 x h 50 cm

746

End XVIII C.

Art. 746
(photo ref. / foto ref.)

Acanthus leaves and roses wall shelf
end XVIII C.
Mensola acanto e rose
fine XVIII Sec.



Decoro
A039 Oro Versailles



746

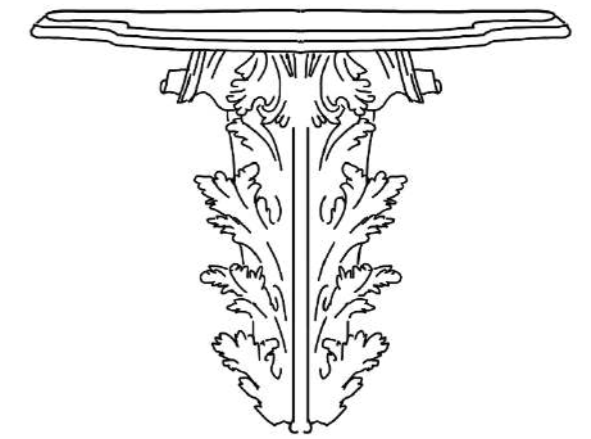

746S

DIMENSIONS / DIMENSIONI
58 x 32 x h 46 cm

735

XVII C. Florentine

Art. 735
(photo ref. / foto ref.)

Scroll wall shelf
XVII C. Florentine
Mensola a cartoccio
XVII Sec. Fiorentino



Decoro
A036 Oro Antico



DIMENSIONS / DIMENSIONI
37 x 19 x h 39 cm

729

End XVIII C. Neoclassical French

Art. 729
(photo ref. / foto ref.)

Wall shelf with garland
end XVIII C. Neoclassical French
Mensola con ghirlanda
fine XVIII Sec. Neoclassico Francese



Decoro
G095 Antico Veneziano



DIMENSIONS / DIMENSIONI
30 x 17 x h 37 cm

591

Neoclassical French

Art. 591
(photo ref. / foto ref.)

Wall shelf with rings
Neoclassical French
Mensola con anelli
Neoclassico Francese



Decoro
A039 Oro Versailles



DIMENSIONS / DIMENSIONI
33 x 22 x h 30 cm

546

End XVIII C. Neoclassical

Art. 546
(photo ref. / foto ref.)

Wall shelf with drapes
end XVIII C. Neoclassical
Mensola con drappi
fine XVIII Sec. Neoclassico



Decoro
A041 Impero



DIMENSIONS / DIMENSIONI
34 x 20 x h 38 cm

485

End XVIII C. Louis XVI French

Art. 485G
(photo ref. / foto ref.)

Wall shelf with acanthus leaf
end XVIII C. Louis XVI French
Mensola con foglia d'acanto
fine XVIII Sec. Luigi XVI Francese

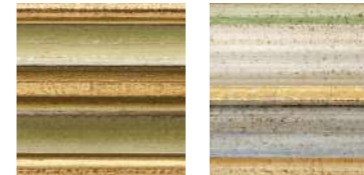

Decoro
G016 Muschio Oro + Policromo



485G

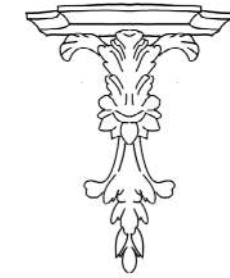

485PP

ARTICLE / ARTICOLO	DIMENSIONS / DIMENSIONI
485G	43 x 25 x h 49 cm
485PP	18 x 10 x h 22 cm

1003

Half XVIII C. English

Art. 1003
(photo ref. / foto ref.)

Flowers and leaves wall shelf
half XVIII C. English
Mensola foglie e fiori
metà XVIII Sec. Inglese



Decoro
A039 Oro Versailles



DIMENSIONS / DIMENSIONI
34 x 18 x h 41 cm

318P

Metà XVIII Sec. Veneziano

Art. 318P
(photo ref. / foto ref.)

Wall shelf with shell
half XVIII C. Venetian
Mensola conchiglia
metà XVIII Sec. Veneziano



Decoro
G006 Provence



DIMENSIONS / DIMENSIONI
22 x 12 x h 16 cm

3

Half XVIII C.

Art. 3

(photo ref. / foto ref.)

Wall shelf with leaves
half XVIII C.
Mensola foglie
metà XVIII Sec.



Decoro
G006 Provence

DIMENSIONS / DIMENSIONI

55 x 26 x h 39 cm

1091

Half XVIII C. Chippendale English

Art. 1091

(photo ref. / foto ref.)

Frill wall shelf
half XVIII C. Chippendale English
Mensola con gala
metà XVIII sec. Chippendale English



Decoro
A039 Oro Versailles

DIMENSIONS / DIMENSIONI

33 x 20 x h 40 cm

1285

Book end

Art. 1285

(photo ref. / foto ref.)

Book end (2 pcs)
Mensola reggilibro (2 pezzi)

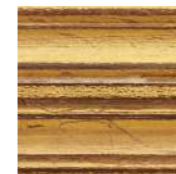

Decoro
G038 Oro Pitti

DIMENSIONS / DIMENSIONI

20 x 14 x h 22 cm

1266

Canova

Art. 1266

(photo ref. / foto ref.)

Aphrodite's "Canova" head
Testa Afrodite "Canova"



Decoro
G043 Ebony

DIMENSIONS / DIMENSIONI

24 x 20 x h 44 cm



1432

Il C. Classic Roman

Art. 1432

(photo ref. / foto ref.)

"Apollo del Belvedere" sculpture
Il C. Classic Roman
"Apollo del Belvedere"
Il Sec. Classico Romano



Decoro
G022 Argento Pitti

145

Classic Greece

Art. 145

(photo ref. / foto ref.)

Athena's head
Classic Greece
Testa di Athena
Classico Grecia



Decoro
G010 Florence



DIMENSIONS / DIMENSIONI

Ø 22 x h 47 cm



DIMENSIONS / DIMENSIONI

39 x 17 x h 48 cm

988

Horse

Art. 988
(photo ref. / foto ref.)

Horse head carving
Testa di cavallo



Decoro
G043 Ebony



DIMENSIONS / DIMENSIONI

30 x 18 x h 36 cm

707

XVIII C. English

Art. 707
(photo ref. / foto ref.)

Grey hound
XVIII C. English
Levriero
XVIII Sec. Inglese



Decoro
G006 Provence

Decoro
G042 Ebony e Oro



707



707BS

DIMENSIONS / DIMENSIONI

44x 30 x h 78 cm

TYPE OF BASE / FORMA BASE

RECTANGULAR BASE / BASE RETTANGOLARE

707

SHAPED BASE / BASE SAGOMATA

707BS

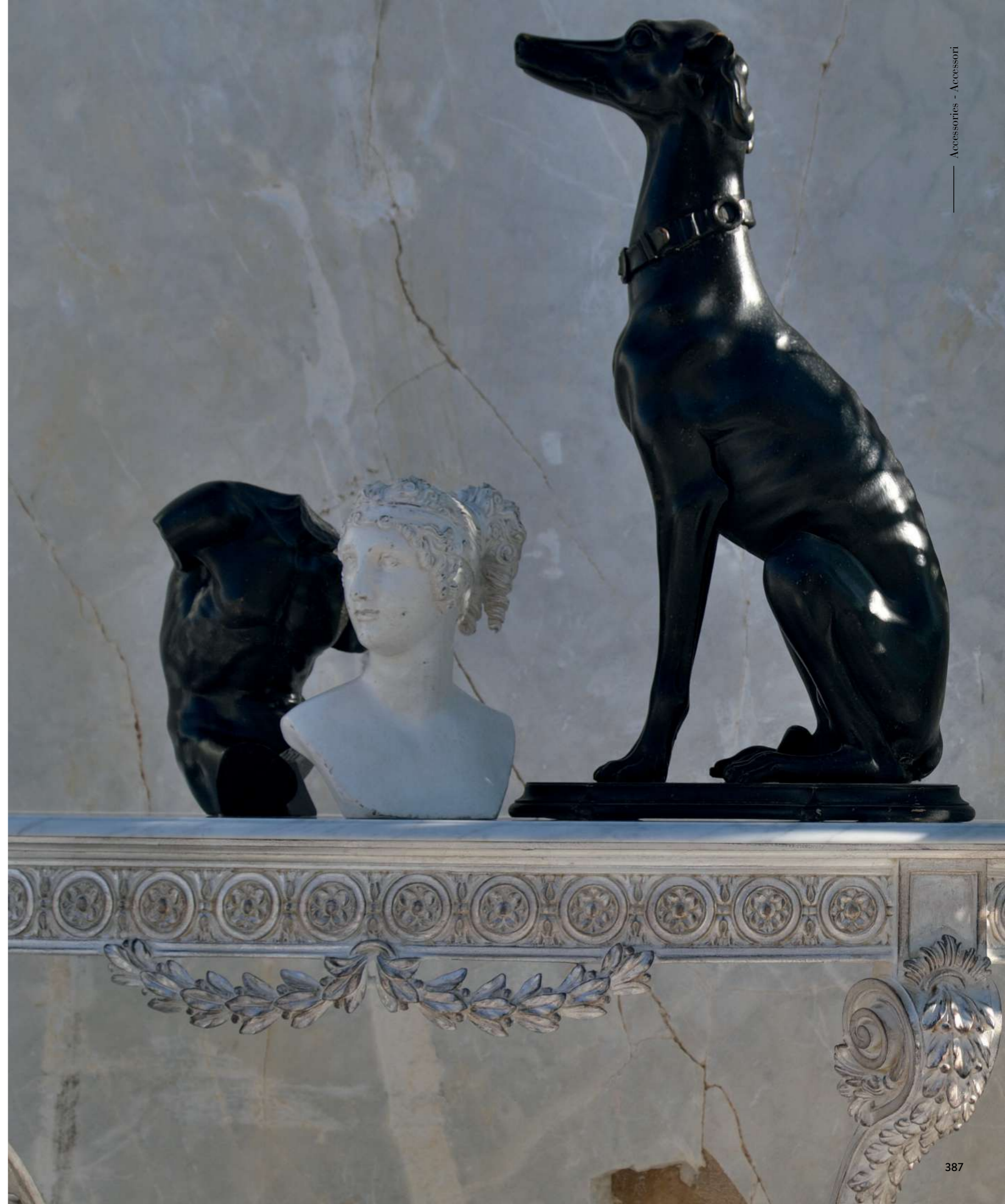

201

Grecian

Art. 201
(photo ref. / foto ref.)

Grecian torso virilis
Busto virile greco



Decoro
G043 Ebony



DIMENSIONS / DIMENSIONI

25 x 16 x h 34 cm

241

XVI C. Roman

Art. 241
(photo ref. / foto ref.)

Torso virilis
XVI C. Roman
Torso virilis
XVI Sec. Roman



Decoro
G043 Ebony



DIMENSIONS / DIMENSIONI

33 x 23 x h 63 cm

449

Sea horse carving

Art. 449
(photo ref. / foto ref.)

Sea Horse carving
Ippocampo



Decoro
G043 Ebony



DIMENSIONS / DIMENSIONI

23 x 13 x h 26 cm

133

XVIII C.

Art. 133
(photo ref. / foto ref.)

Blackmoor ornament
XVIII C. (single item)
Moretto con cesto
XVIII Sec. (articolo singolo)



Decoro
G043 Ebony



DIMENSIONS / DIMENSIONI

Ø 20 x h 68 cm

Primavera

Art. BSS PR



Art. BSS PR
(photo ref. / foto ref.)

4 seasons bas-relief ornament
Primavera
Bassorilievo 4 stagioni
Primavera

DIMENSIONS / DIMENSIONI

Ø 90 cm

Estate

Art. BSS ES



Art. BSS ES
(photo ref. / foto ref.)

4 seasons bas-relief ornament
Estate
Bassorilievo 4 stagioni
Estate

DIMENSIONS / DIMENSIONI

Ø 90 cm

Autunno

Art. BSS AT



Art. BSS AT
(photo ref. / foto ref.)

4 seasons bas-relief ornament
Autunno
Bassorilievo 4 stagioni
Autunno

DIMENSIONS / DIMENSIONI

Ø 90 cm

Inverno

Art. BSS IN



Art. BSS IN
(photo ref. / foto ref.)

4 seasons bas-relief ornament
Inverno
Bassorilievo 4 stagioni
Inverno

DIMENSIONS / DIMENSIONI

Ø 90 cm

Bas-relief ornament

End. XVIII C. Neoclassical Italian



Art. B-Giove



Art. A-Apollo

Art. 1366SBR A-Apollo
(photo ref. / foto ref.)

Gypsum bas-relief
for frame 1366SBR
Bassorilievo in gesso
per cornice 1366SBR

Art. 1366SBR B-Giove
(photo ref. / foto ref.)

Gypsum bas-relief
for frame 1366SBR
Bassorilievo in gesso
per cornice 1366SBR

DIMENSIONS / DIMENSIONI		
Ø 121 cm		
PASSE-PARTOUT OPTIONS / OPZIONI PASSE-PARTOUT		
COLOURED GLASS / VETRO RETROVERNICIATO	SEMI PRECIOUS STONE / PIETRA SEMI-PREZIOSA	
WOODEN FRAME FINISH / FINITURE CORNICE IN LEGNO		
STANDARD	ELITE	LUXURY



Bas-relief ornament



Art. 356PBR A



Art. 365PBR B

Art. 356PBR A
(photo ref. / foto ref.)

Frame with Musa A
gypsum bas relief
Cornice con bassorilievo
in gesso Musa A

Art. 365PBR B
(photo ref. / foto ref.)

Frame with Musa B
gypsum bas relief
Cornice con bassorilievo
in gesso Musa B

DIMENSIONS / DIMENSIONI		
Ø 82 cm		
WOODEN FRAME FINISH / FINITURE CORNICE IN LEGNO		
STANDARD	ELITE	LUXURY

Bas-relief ornament

Art. 290PBR



Art. 290PBR
(photo ref. / foto ref.)

Frame with gypsum bas relief
Cornice con bassorilievo in gesso

DIMENSIONS / DIMENSIONI	
80 x h 72 cm	
WOODEN FRAME FINISH / FINITURE CORNICE IN LEGNO	
GOLD LEAF / FOGLIA ORO	SILVER LEAF / FOGLIA ARGENTO
✓	✓

WOOD FINISHES
FINTURE LEGNO



Classic



A004 Gardenia

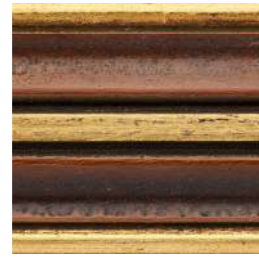

A029 Bolo e Oro



G003 Magnolia



G007 Canova

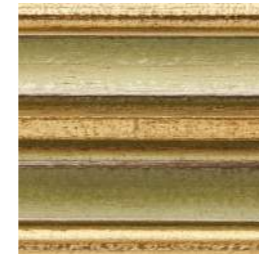

G016 Muschio Oro

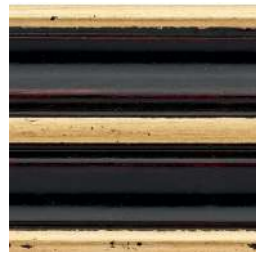

A041 Impero



A071 Argento e Oro



G088 Rosso Argento



G095 Antico Veneziano



G094 Prestige



G096 Bianco Fiorentino



G110 Barocco e Argento

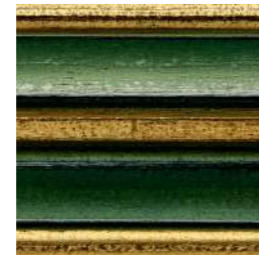

A040 Napoleon

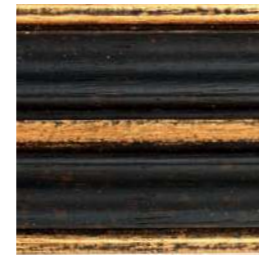

G042 Ebony e Oro



G008 Trianon

Gold Leaf

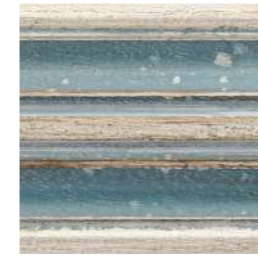

A018 Zaffiro



G038 Oro Pitti



G017 Ciliegio e Argento



A021 Argento Soleil Decapè



A033 Oro Soleil Decapè



G035 Oro Decapè Antico

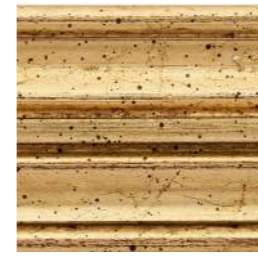

A036 Oro Antico

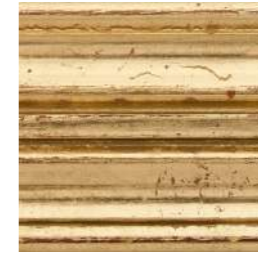

A039 Oro Versailles



A077 Oro Francese



G079 Oro Leggero



G081 Oro Antiquariato



A085 Royal Gold

Shabby Chic



G006 Provence



G010 Florence



G011 Vanwood



G021 Greige

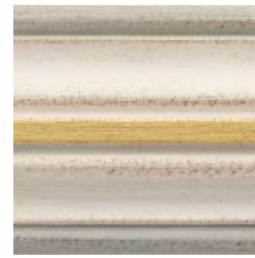

A014 A.C.O.



G080 Grey Stone



G009 Blanc



G061 Ciliegio e Oro



A072 Greige e Oro

Trendy



A013 Vogue

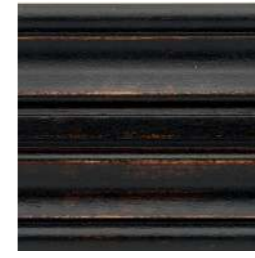

G043 Ebony



G086 Noir

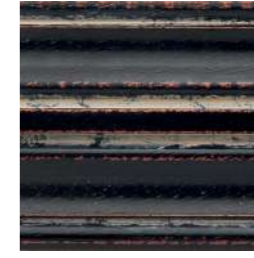

G087 Nero Fiammingo



A066 Riace

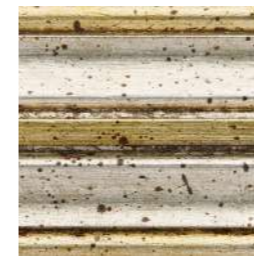

A026 Argento e Mecca

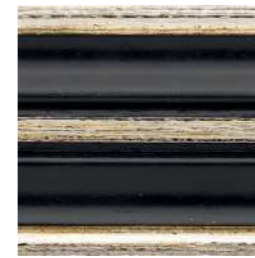

G098 Noir e Argento



G115 Cuprum

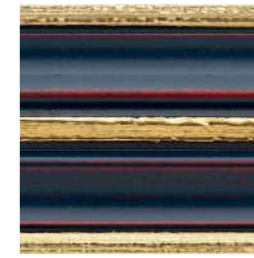

G117 Cobalto Oro

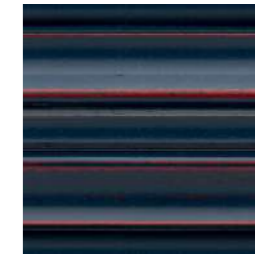

G116 Cobalto



G118 Smoke



G119 Smoke e Oro

Natural Wood



G027 Colonial



G028 Noce

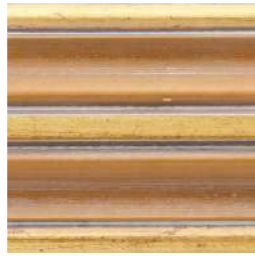

A030 Castagna e Oro

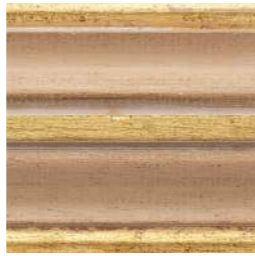

G032 Pickled Pine e Oro



G067 Rovere Sbiancato



A015 Policromo



G065 Pickled Pine e Argento



G082 Pickled Pine



G089 Ciliegio Antico

Silver Leaf



G022 Argento Pitti

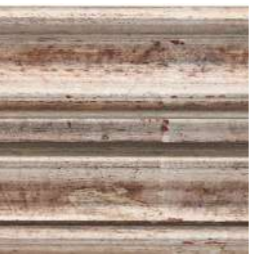

A023 Argento

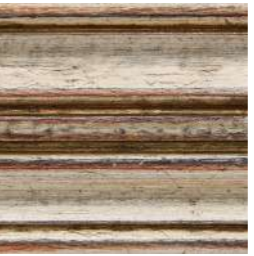

A024 Argento Luce



A025 Argento Antico



A111 Perlage



G105 Argento Leggero



G112 Rinascimento

MARBLES AND SEMIPRECIOUS STONE
MARMI E PIETRE SEMIPREZIOSE



Marbles_ Marmi



Bianco Carrara



Giallo Oro



Nero Marquina



Travertino

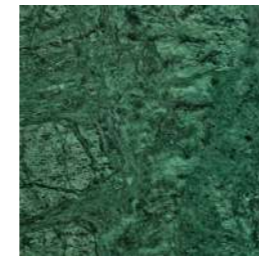

Verde Guatemala



Travertino Scuro



Rosso Verona



Chocolate



Coffee Bean

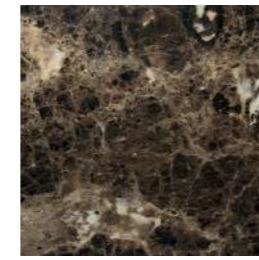

Emperador Dark



Emperador Chiaro



Crema Valencia



Bianco Lasa

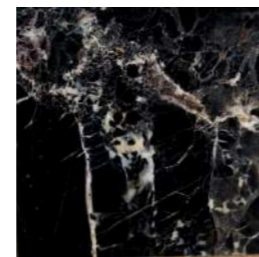

Noir Saint Laurent



Red Jasper



Golden Lightning



Rosa Estremoz



Kenia Black



Bianco Gioia



Rosso Francia



Bianco Assoluto

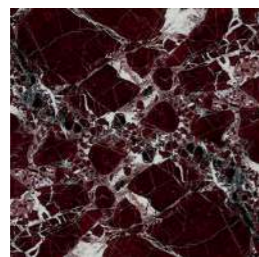

Rosso Levante



Breccia Capraia



Calacatta Oro



Nero Portoro



Onice Bianco



Onice Stalattite Oro



Onice Verde Smeraldo



Calacatta Classico

Semi precious stone_ Pietre semipreziose

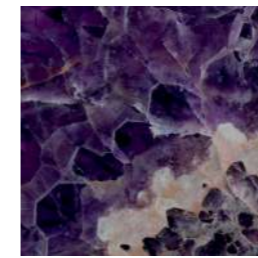

Ametista

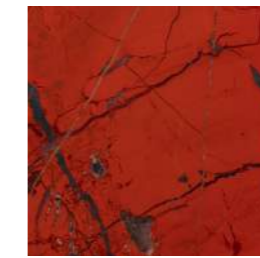

Diaspro Rosso

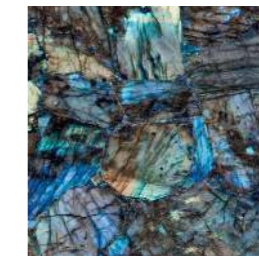

Labradorite

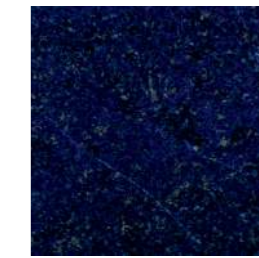

Lapis Pirite



Malachite

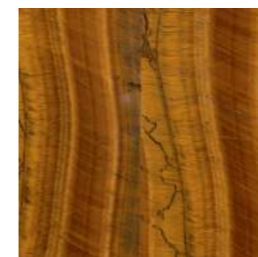

Occhio di tigre

Roberto Giovannini srl reserves the right to make changes to the materials, coatings, finishes and design of the products presented in this catalogue without prior notice. The textures, the colours of materials and finishes are purely indicative, as they are subject to the tolerances of the printing processes. All dimensions of Roberto Giovannini srl products are expressed in centimeters. All Roberto Giovannini srl products are protected by copyright.

Roberto Giovannini srl si riserva di apportare senza preavviso modifiche nei materiali, nei rivestimenti, nelle finiture e nei disegni dei prodotti presenti in questo catalogo. Le texture, i colori dei materiali e delle finiture hanno valore indicativo, in quanto soggetti alle tolleranze dei processi di stampa. Tutte le dimensioni dei prodotti Roberto Giovannini srl sono espresse in centimetri. I prodotti Roberto Giovannini sono protetti da copyright.

Art director
Ottomani design

Graphic project
Adhocspaziocreativo.it

Photo
Lorenzo Borgianni
Deep Blue Studio

Print
Cappelli Artigrafiche S.r.l.

© Roberto Giovannini Srl - July 2024



Roberto Giovannini S.r.l.

Via dell'Artigianato 54b

50025 Località Cerbaia - Montespertoli (FI) - Italy

T. +39 0571 670200

F. +39 0571 670709

info@robertogiovannini.com

www.robertogiovannini.com

