

FIAM



HOME OFFICE: SCRIVANIE • TAVOLI RIUNIONI • LIBRERIE • MENSOLE • CASSETTIERE
HOME OFFICE: desks • meeting tables • bookshelves • shelves • drawer units

La poesia è la vanità
di una materia
capace di riflettere
ciò che ci circonda
e di moltiplicare
i nostri punti di vista
sul reale.

Poetry is the vanity
of a material capable
of reflecting what
is around us increasing
our points of view
on reality.

Vittorio Livi

Fiam, cultura del vetro	02
Fiam, glass culture	
Indice prodotti	32
Product index	
Scrivanie	36
Desks	
Tavoli riunioni	72
Meeting tables	
Librerie, Mensole, Cassettiere	86
Bookshelves, Shelves, Drawer units	
Mini collection	110
Mini collection	
I Customizzabili	116
The Customizables	
Schede tecniche	120
Technical data	
Fiam, garanzia di qualità	148
Fiam, guarantee of quality	

Dal vetro nasce vetro.

Sabbia e calce che possono essere riciclati all'infinito.
Frammenti del passato che ritornano vivi e partecipi di questo presente
per accompagnarci nel nostro futuro.

Glass comes from glass.

Sand and lime that can be endlessly recycled.
Fragments of the past that come back alive and participate
in this present to accompany us toward our future.

Du verre vient le verre.

Du sable et de la chaux qui peuvent être recyclés à l'infini.
Des fragments du passé qui reviennent vivants et participent
à ce présent pour nous accompagner dans notre futur.

Glas entsteht aus Glas.

Sand und Kalk, die endlos recyclet werden können.
Fragmente der Vergangenheit, die wieder lebendig werden und
an der Gegenwart teilnehmen, um uns in unsere Zukunft zu begleiten.

La nostra storia.

Anni di ricerca e sperimentazione.
Una passione che attraversa le generazioni.

Our history.

Years of research and experimentation.
A passion that is handed down through generations.

Notre histoire.

Des années de recherche et d'expérimentation.
Une passion qui traverse les générations.

Unsere Geschichte.

Jahre der Forschung und des Experimentierens.
Eine Leidenschaft, die über Generationen weitergegeben wird.





Un processo fatto di attenzione e cura.

Sensibilità per la materia. Delicatezza, dedizione e precisione.
Fin da principio.

A process made of attention and care.

Sensitivity to the material. Delicacy, dedication and precision.
From the very beginning.

Un processus d'attention et de soin.

Sensibilité pour le matériau. Délicatesse, dévouement et précision.
Dès le début.

Ein Prozess der Aufmerksamkeit und Sorgfalt.

Sensibilität für das Material. Feinfühligkeit, Hingabe und Präzision.
Von Anfang an.







Il calore per plasmare.

Un cuore ardente.

La capacità di domare le temperature per dare vita a nuove forme.

Heating to forge.

A burning heart.

The ability to tame high temperatures to give life to new shapes.

La chaleur pour mouler.

Un cœur brûlant.

La capacité de dompter les températures pour donner vie à de nouvelles formes.

Erhitzen zum Schmieden.

Ein brennendes Herz.

Die Fähigkeit, Temperaturen zu zähmen, um neue Formen zum Leben zu erwecken.

Passione per la materia.

Meticolosità, pazienza e attenzione.
Raffinatezza e sensibilità nel prendersi cura di ogni particolare.

Passion for the material.

Meticulousness, patience and attention.
Refinement and sensitivity in taking care of every detail.

La passion pour le matériau.

Méticulosité, patience et attention.
Raffinement et sensibilité dans le soin apporté à chaque détail.

Leidenschaft für das Material.

Empfindsamkeit für das Material. Zartheit, Hingabe und Präzision.
Von Anfang an.



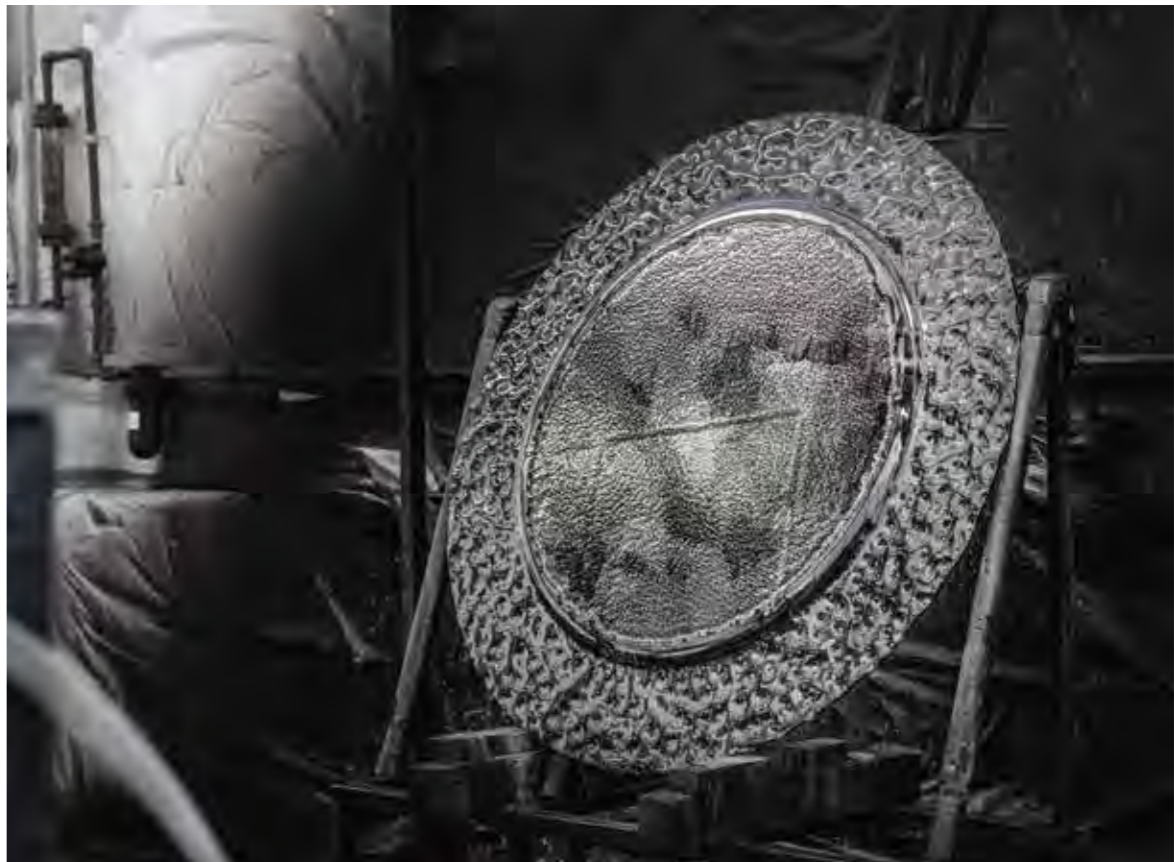





Il vetro, una nuova materia.

Spessori, morbidezza, tridimensionalità.

La nostra ricerca ci ha portato a reinterpretare questo materiale antico. Abbiamo superato il concetto di lastra e, attraverso le nostre fusioni, gli abbiamo conferito una nuova sensorialità.

Glass, a new material.

Thicknesses, softness, three-dimensionality.

Our research led us to reinterpret this ancient material.

We have gone beyond the concept of glass sheet and, through our fusion techniques, we have given it a new sensoriality.

Le verre, un nouveau matériau.

Épaisseur, douceur, tridimensionnalité.

Nos recherches nous ont amenés à réinterpréter ce matériau ancien.

Nous avons dépassé le concept de la dalle de verre et,

par nos fusions, nous lui avons donné une nouvelle sensorialité.

Das Glas, ein neues Material.

Die Dicken, die Weichheit, die Dreidimensionalität.

Unsere Recherchen brachten uns dazu, dieses alte Material neu zu interpretieren.

Wir sind über das Konzept der Glasscheibe hinausgegangen und haben

ihm durch unsere Verschmelzungen eine neue Sinnlichkeit verliehen.



SCRIVANIE | DESKS

**bright**

design Valerio Cometti

56

**graph**

design Xavier Lust

68

**hype**

design Studio Klass

40

Indice prodotti

Product index

**LLT home office**

design Dante O. Benini - Luca Gonzo

60

**LLT ofx executive**

design Dante O. Benini - Luca Gonzo

64

**rialto isola**

design CRS Fiam

54

**rialto L**

design CRS Fiam

48

**rialto L wall mounted**

design CRS Fiam

52

**rialto scrivania**

design CRS Fiam

44

TAVOLI RIUNIONI | MEETING TABLES



LLT ofx meeting

design Dante O. Benini - Luca Gonzo

76



luxor

design Rodolfo Dordoni

82

MENSOLE | SHELVES



babila

design Luca Casini

94



mensole rialto L

design CRS Fiam

96

LIBRERIE | BOOKCASES



inori

design Setsu & Shinobu Ito

90

CASSETTIERE | DRAWER UNITS



luminare cassettiere

design Roberto Paoli

102



rialto cassettiere

design CRS Fiam

106



Scrivanie
Desks



bright	56
graph	68
hype	40
LLT home office	60
LLT ofx executive	64
rialto isola	54
rialto L	48
rialto L wall mounted	52
rialto scrivania	44

The Customizables	116
-------------------	-----

Scrivanie

Desks



hype

design Studio Klass

Scrivitoio con piano in vetro da 12 mm fuso a gran fuoco, temperato e retroverniciato con tinte metallizzate Grigio Lava, Marrone Ramato o Champagne. Base in metallo verniciato, finitura Grigio Lava.

Desk with 12 mm fused, tempered and back-lacquered glass top with metal shades Lava Grey, Copper Brown or Champagne. Metal painted base, "Lava Grey" finish.

Bureau avec plateau en verre en fusion de 12mm, trempé et verni dessous avec des teintes métallisées Gris Lave, Cuivre Marron ou Champagne. Base en métal verni, finition Gris Lave.

Schreibtisch mit Platte aus 12 mm geschmolzenem und gehärtetem Glas in den folgenden Metallfarben unterlackiert: Lavagrau, Kupfer braun oder champagnerfarbig. Untergestell aus Metall in der Farbvariante Lavagrau.



Piano in vetro fuso, finitura grigio lava.
Fused glass top, lava grey finition.
120 x 60 x 75 cm
62" x 23 5/8" x 29 1/2"

rialto scrivania

design CRS Fiam



Collezione di scrivanie in vetro curvato da 15 mm disponibili in varie misure. Su richiesta: profili in alluminio brillantato. Disponibile anche su misura.

Collection of desks in 15 mm curved glass, available in various sizes. On request: strips in polished aluminium. Also available custom-sized.

Collection de bureaux en verre cintré de 15 mm disponibles dans plusieurs dimensions. Sur demande: profils en aluminium brillanté. Egalement disponible sur mesure.

Kollektion von Schreibtischen aus 15 mm starkem gebogenem Glas in diversen Abmessungen. Auf Wunsch: geglänzte Aluminiumprofile. Auch als Maßanfertigung lieferbar.

Scrivania.
Desk.

160 x 80 x 73 cm
63" x 31 1/2" x 28 3/4"

Sedia Pliè.
Pliè chair.

Cassettiera Luminare.
Luminare drawer unit.



Scrivanìa.
Desk.
160 x 80 x 73 cm
63" x 31 1/2" x 28 3/4"

Sedia Pliè
Pliè chair.

Cassettera Luminare.
Luminare drawer unit.

Mensolè Babila.
Babila shelves.

rialto L

design CRS Fiam

Scrivania in vetro curvato da 15 mm, abbinata a cassetiera in legno laccato opaco nei colori bianco o nero con frontali in vetro verniciati in abbinamento al colore della struttura. Disponibile anche su misura.

Desk in 15 mm-thick curved glass combined with drawer unit in white or black matt lacquered wood, with fronts in glass varnished to match the structure colour. Customized Rialto desk available on demand.

Bureau en verre cintré de 15 mm, avec meuble à tiroirs en bois laqué opaque dans les coloris blanc ou noir, avec façades en verre vernies de couleur assortie à la structure. Egalement disponible sur mesure.

Schreibtisch aus 15 mm starkem gebogenem Glas, kombiniert mit Schubladenelement aus matt lackiertem Holz in Weiß oder Schwarz. Fronten aus farblich zum Korpus passend lackiertem Glas. Auch als Maßanfertigung lieferbar.

Scrivania con cassetiera.
Desk with drawer unit.
160 x 70 x 73 cm
63" x 27 9/16" x 28 3/4"
Sedia Dress.
Dress chair.

Scrivania con cassetiera.
Desk with drawer unit.
160 x 70 x 73 cm
63" x 27 9/16" x 28 3/4"
Sedia Dress.
Dress chair.



rialto L wall mounted

design CRS Fiam

Scrivania in vetro trasparente curvato da 15 mm con una doppia piastra in alluminio brillantato per fissaggio a parete. Disponibile anche su misura.

Desk in 15 mm-thick transparent curved glass with a double bright-finish aluminium plate for wall-mounting. Customized Rialto desk available on demand.

Bureau en verre transparent cintré de 15 mm, assorti à une double plaque en aluminium poli pour fixation murale. Egalement disponible sur mesure.

Schreibtisch aus 15 mm starkem, transparentem, gebogenem Glas, kombiniert mit einer doppelten Leiste aus poliertem Aluminium zur Befestigung an der Wand. Auch als Maßanfertigung lieferbar.

Scrivania.
Desk.
160 x 70 x 73 cm
63" x 27 ⁹/₁₆" x 28 ³/₄"



rialto isola

design CRS Fiam

Scrivania composta da un ripiano principale e da un ripiano di servizio in vetro trasparente curvato da 15 mm sul lato sinistro. Particolari in alluminio brillantato. Disponibile anche su misura. Il ripiano di servizio può essere collocato a destra o sinistra senza sovrapprezzo, specificandolo all'ordine. Cassettiera non inclusa nel prezzo.

Desk comprising a main top and a shelf in curved 15 mm transparent glass on the left side. Details in gloss aluminium. Also available custom-sized. The shelf under the main top can be positioned on the left or on the right side without surcharge, by specifying it into the order. Drawer unit not included.

Bureau constitué d'un plateau principal et d'un plateau de service en verre transparent cintré de 15 mma gauche. Détails en aluminium brillanté. Egalement disponible sur mesure. L'étagère de service peut être positionné à gauche ou à droite sans supplément de prix mais seulement en le spécifiant sur la commande. Le caisson n'est pas inclus.

Schreibtisch mit Querplatte aus 15 mm starkem, gebogenem, transparentem Glas links. Details aus poliertem Aluminium. Auch Maßanfertigungen möglich. Das Fachboden kann sowohl rechts oder links ohne Aufpreis aber nur ab Bestellung ausgestellt werden. Kommode nicht enthalten.

Scrivania.
Desk.

Piano principale / Main top:
170 x 70 x 73 cm
67" x 27 9/16" x 28 3/4"

Piano di servizio / Side shelf:
140 x 50 x 60
55 1/8" x 19 11/16" x 23 5/8"

Cassettiera **Luminare**.
Luminare drawer unit.

Mensole **Rialto L**.
Rialto L shelves.

bright

design CRS Fiam



Scrivania in vetro temperato da 15 mm smontabile con supporti di fissaggio in alluminio ed acciaio. Disponibile anche su misura.

Desk in 15 mm-thick tempered glass with aluminium and steel mounting supports. Also available custom-sized.

Bureau en verre trempé et soudé de 15 mm. Supports de fixation en aluminium et acier, démontables. Egalement disponible sur mesure.

Schreibtisch aus 15 mm starkem, gehärtetem Glas. Zerlegbare Aluminium und Stahl-Befestigungselementen. Auch als Maßanfertigung lieferbar.

Scrivania.
Desk.

180 x 80 x 73 cm
70 7/8" x 31 1/2" x 28 3/4"

Specchio **Caadre TV**.
Caadre TV mirror.





LLT home office

design Dante O. Benini - Luca Gonzo

Scrivania con piano in vetro trasparente da 15 con bisellatura su due lati corti, struttura gambe in vetro trasparente saldato da 15 con bisellatura sul bordo. Particolari di fissaggio in acciaio inox. Disponibile anche con piani su misura.

Desk composed of a 15 mm thick transparent glass top with bevelled edges on the two shorter sides and of a base in 15 mm thick transparent welded glass with bevelled edge. Fastening elements in stainless steel. Also available with tops of customized size.

Bureau se composant d'un plateau en verre transparent de 15 mm avec biseautage sur les deux côtés courts et d'un piétement en verre transparent soudé, épaisseur 15 mm, avec bords biseautés. Éléments de fixation en acier inoxydable. Également disponible avec plateau sur mesure.

Schreibtisch mit Platte aus transparentem 15 mm starkem Glas, Facettenschliff auf den zwei kürzeren Seiten. Untergestell aus transparentem 15 mm starkem verschweisstem Glas, Facettenschliff auf den Kanten. Verbindungselemente aus Edelstahl. Auch mit Maßgefertigter Platte.

Scrivania.
Desk.
180 x 80 x 72 cm
70 7/8" x 31 1/2" x 28 3/8"



Scrivania.
Desk.
160 x 70 x 72 cm
63" x 27 9/16" x 28 3/8"



LLT ofx executive

design Dante O. Benini - Luca Gonzo

Scrivania direzionale in vetro trasparente da 19 mm. Il piano è appoggiato sulle basi in vetro incollato e i fori presenti hanno la funzione di passacavi. LLT ofx executive è disponibile anche con piani su misura, fino ad una lunghezza di 260 cm.

Executive desk in 19 mm thick transparent glass. The top rests on the bases in glued transparent glass and is equipped with cable entry holes. LLT ofx executive is also available with custom-sized top up to 260 cm length.

Bureau exécutif se composant d'un plateau en verre transparent de 19 mm et d'un piétement en verre transparent soudé. Trous pour le passage des cables. Disponible avec plateau sur mesure jusqu'à une longueur de cm 260.

Schreibtisch-Besprechungstisch mit Platte aus transparentem 19 mm starkem Glas, und Untergestell aus transparentem 19 mm starkem verschweisstem Glas. Kabelführungslöcher. Auch mit Maßgefertigter Platte erhältlich bis max. Länge von 260 cm.



Scrivanía.
Desk.
180 x 90 x 74 cm
70 7/8" x 35 7/16" x 29 1/8"
Cassettiera Rialto.
Rialto drawer unit.
Consolle LLT.
LLT console.
Lampada L'Astra.
L'Astra table lamp.

graph

design Xavier Lust



Scrivania composta da base in vetro trasparente curvato da 19 mm e piano in vetro trasparente da 15 mm temperato con piastre di aggancio in acciaio inox.

Desk comprising base in 19 mm-thick curved transparent glass and 15 mm-thick tempered transparent glass top with stainless steel connecting plates.

Bureau composé d'une base en verre transparent cintré de 19 mm et d'un plateau en verre transparent de 15 mm avec plaques de fixation en acier inoxydable.

Desk comprising base in 19 mm-thick curved transparent glass and 15 mm-thick tempered transparent glass top with stainless steel connecting plates.

Scrivania.
Desk.

220 x 80 x 74 cm
86 5/8" x 31 1/2" x 29 1/8"

Cassettiera Luminare.
Luminare drawer unit.



Scrivania.
Desk.
220 x 80 x 74 cm
86 5/8" x 31 1/2" x 29 1/8"
Cassettiera Luminare.
Luminare drawer unit.

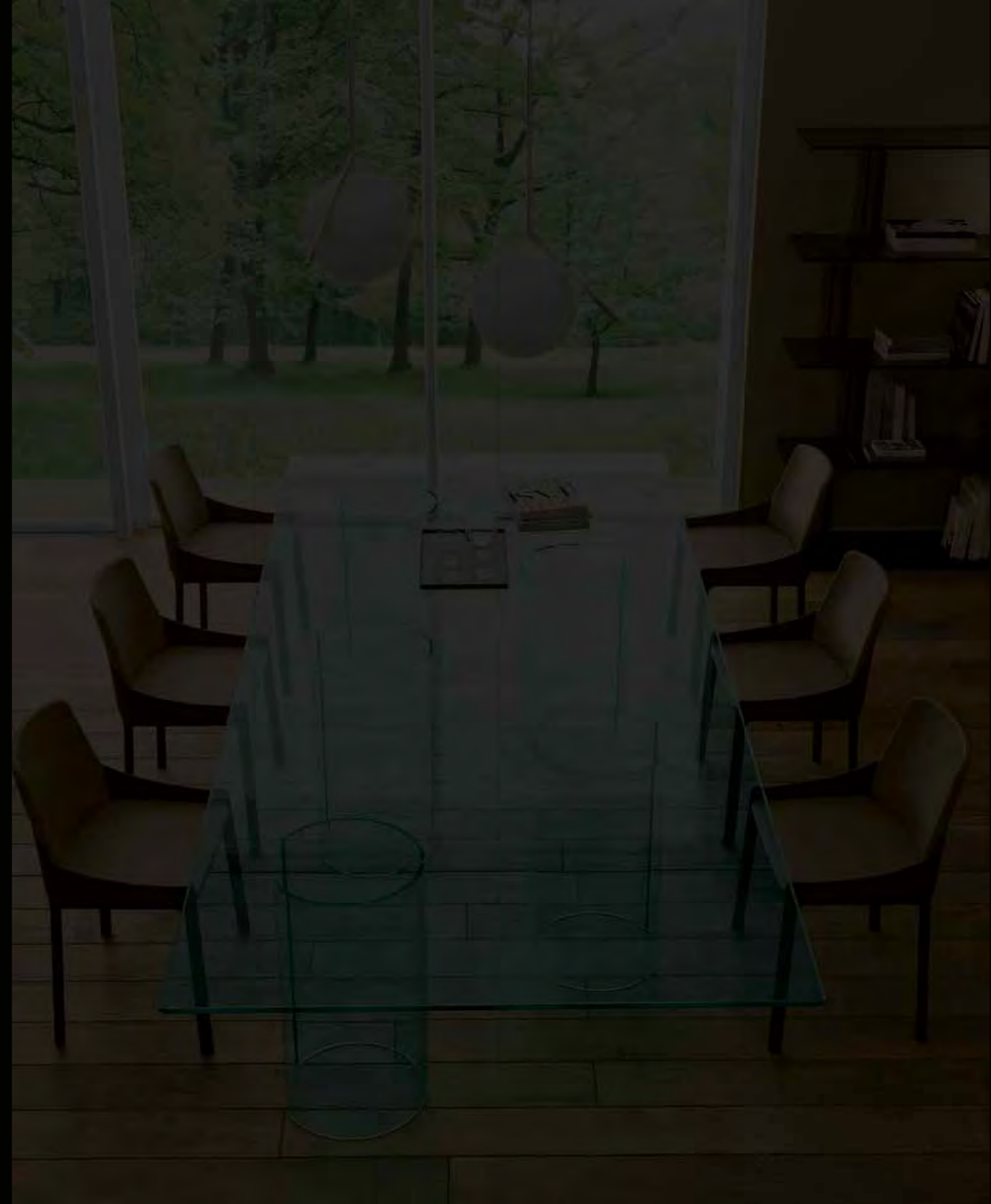

Tavoli riunioni
Meeting tables

LLT ofx meeting 76
luxor 82

The Customizables 116

Tavoli riunioni

Meeting tables

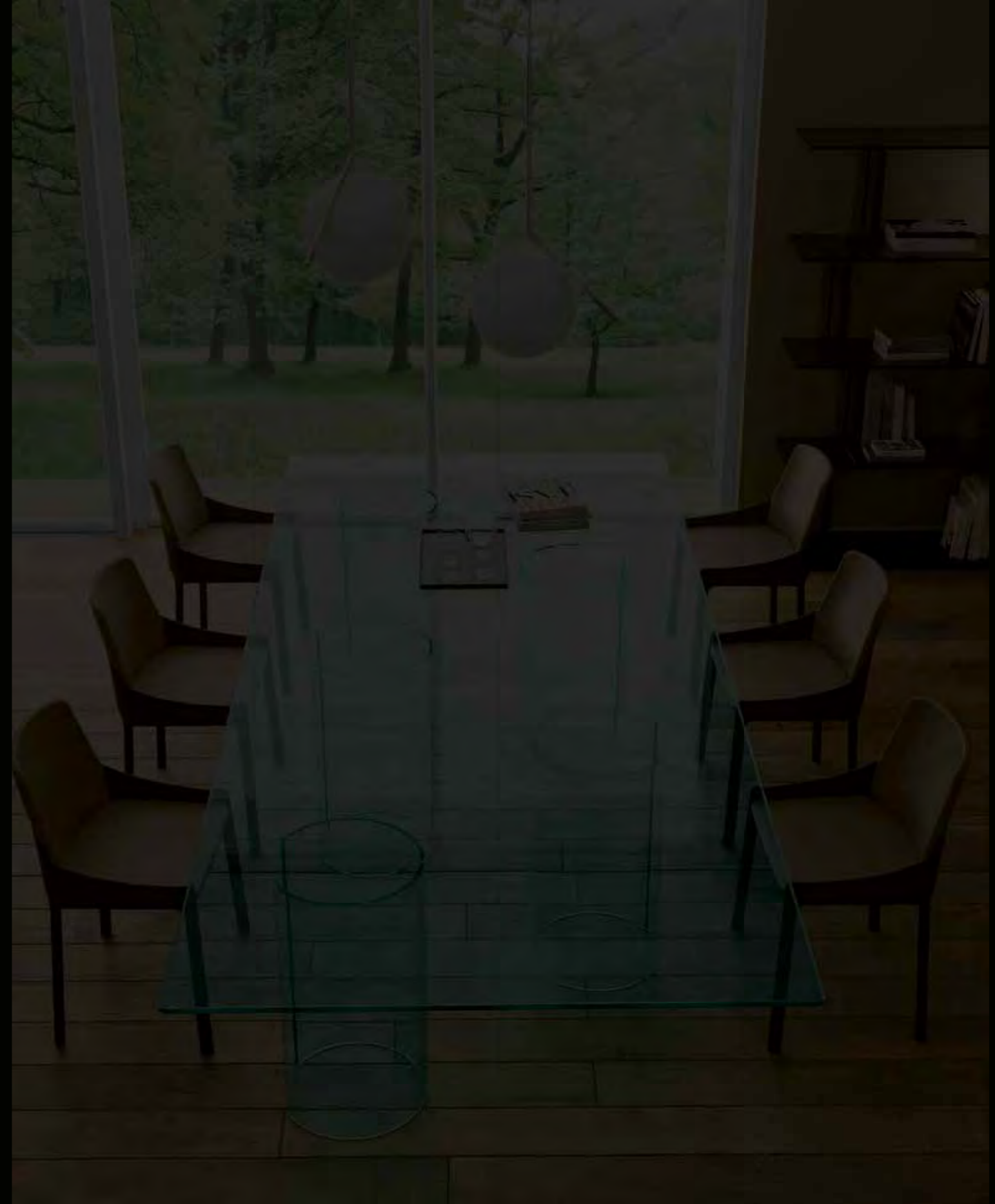



LLT ofx meeting

design Dante O. Benini - Luca Gonzo

Tavolo riunioni in vetro trasparente da 19 mm. Il piano è appoggiato sulle basi in vetro incollato e i fori presenti hanno la funzione di passacavi. LLT ofx meeting è disponibile anche con piani su misura, fino ad una dimensione massima 350x120 cm.

Meeting table in 19 mm thick transparent glass. The top rests on the bases in glued transparent glass and is equipped with cable entry holes. LLT ofx meeting is also available with custom-sized top up to 350x120 cm.

Table de réunion se composant d'un plateau en verre transparent de 19 mm et d'un piétement en verre transparent soudé avec des trous pour le passage des cables. Disponible avec plateau sur mesure jusqu'à 350x120 cm.

Besprechungstisch mit Platte aus transparentem 19 mm starkem Glas, und Untergestell aus transparentem 19 mm starkem verschweisstem Glas. Kabelführungslöcher. Auch mit Maßgefertigter Platte erhältlich bis max. 350x120 cm.



Tavolo riunioni.
Meeting table.
350 x 120 x 74 cm
137 13/16" x 47 1/4" x 29 1/8"
Sedia Dress.
Dress chair.
Consolle LLT.
LLT consolle.
Tavolino Magique.
Magique side table.





luxor

design Rodolfo Dordoni

Tavolo con piano in vetro fumé o bronzo stratificato da 8+8 mm finitura filo lucido tondo, disponibile anche in vetro trasparente o extralight. A seconda della misura e della configurazione desiderata base composta da 2, 3 o 4 cilindri (Ø 40 cm) in vetro da 10 mm, disponibile fumé, bronzo trasparente o extralight. Disponibile anche con piani a misura.

Table with layered glass top 8+8 mm-thick brilliant polished rim, in smoked or bronze glass also available in transparent glass or extralight glass. 10 mm-thick curved glass base, composed of 2, 3 or 4 cylinders (Ø 40 cm) depending upon the size and the shape requested. Bases are available in smoked glass, bronze glass, transparent glass or extralight glass. Also available with tops of customized size.

Table avec plateau en verre feuilleté de 8+8 mm fumé ou bronze finition chant poli arrondi, ou en verre trempé transparent ou extralight. Base en verre cintré de 10 mm se composant de 2, 3 ou 4 cylindres (Ø 40 cm) dépendant de la mesure ou de la configuration désirée. Disponible en verre fumé, en verre bronze, en verre transparent ou en verre extralight. La table Luxor est également disponible avec de dessus sur mesure.

Tisch mit 8+8 mm-starker Schichtglasplatte in Rauch- oder Bronze-Glas oder in transparentem bzw. extralight gehärtetem Glas. Untergestell bestehend aus 2, 3 bzw. 4 Zylindern (Durchmesser 40 cm) abhängig von den gewünschten Massen und Gestaltung, aus 10 mmstarkem gebogenem Glas, lieferbar in den Ausführungen Rauchglas, oder Bronzeglas, transparentes bzw. extralight Glas. Auch mit maßgefertigter Platte lieferbar.

Tavolo riunioni.
Meeting table.
350 x 120 x 74 cm
137 13/16" x 47 1/4" x 29 1/8"

Libreria Inori.
Inori bookcase.

Sedia Plié.
Plié chair.





Librerie, Mensole, Cassettiere
Bookshelves, Shelves, Drawer Units

babila	96
inori	90
luminare cassettera	102
mensole rialto L	98
rialto cassettera	106
The Customizables	116

Librerie, Mensole, Cassettiere

Bookshelves, Shelves, Drawer Units



inori & inori freestanding

design Setsu e Shinobu Ito

Sistema composto da elementi in vetro o legno modulari. La modularità e versatilità ne permette l'utilizzo come libreria, espositore, contenitore, porta Tv.

Il sistema si sviluppa anche in situazione autoportanti (inori freestanding): nelle versioni in vetro e nella misura larga cm 240, da altezza minima 135 cm sino all'altezza massima 180 cm il sistema prevede delle barre di irrigidimento in alluminio anodizzato nero.

System consisting of modular glass or wood elements. Its modularity and versatility allow it to be used as a bookcase, display case, storage unit or TV unit.

The system can also be used to construct free-standing compositions (inori freestanding): in glass versions and in width 240 cm, from a height of minimum 135 cm up to the maximum height of 180 cm the system is complete with black anodised aluminium reinforcement bars.

Système composé d'éléments modulaires en verre ou bois. Sa modularité et sa polyvalence permettent de l'utiliser comme une bibliothèque, un présentoir, un meuble de rangement, un meuble TV.

Possibilità di sistema autoportante (inori freestanding): dans les versions en verre et dans la largeur de 240 cm, d'une hauteur minimale de 135 cm jusqu'à une hauteur maximale de 180 cm, le système est doté de barres d'armature en aluminium anodisé noir.

System aus modularen Glas- oder Holz-Elementen. Vielseitig einsetzbar und beliebig kombinierbar, als Bücherregal, Ausstellungsregal, TV-Element usw.

Auch freistehend als Raumteiler (inori freestanding (aus Glas Breite 240 cm, Höhe mindestens 135 cm, maximal 180 cm, mit Verstärkungen aus Schwarz eloxiertem Aluminium).

Libreria freestanding con base in vetro fumè retroverniciato nero, ripiani in vetro fumè, montanti in vetro trasparente H 32 e 42 cm.

Freestanding bookshelf with black back-painted smoked glass bases, Smoked glass shelves, Transparent glass uprights, H 32 and 42 cm.

240 x 36,5 x 191 cm (con accessorio dedicato).
94 1/2" x 14 3/8" x 75 3/16" (with reinforcement bars).





Libreria con base in vetro retroverniciato nero, ripiani in vetro trasparente, montanti in vetro trasparente H42 cm.
Bookshelf with black back-painted glass base, transparent glass shelves, transparent glass uprights H42cm.
240 x 36,5 x 178 cm
94 1/2" x 14 3/8" x 70"
Sedia Plié.
Plié chair.
Tavolo Luxor.
Luxor table.



Libreria con base in vetro retroverniciato nero,
ripiani in vetro extralight, montanti
in vetro extralight H42 cm.

Bookshelf with black back-painted glass base,
extralight glass shelves, extralight glass
uprights H42 cm.

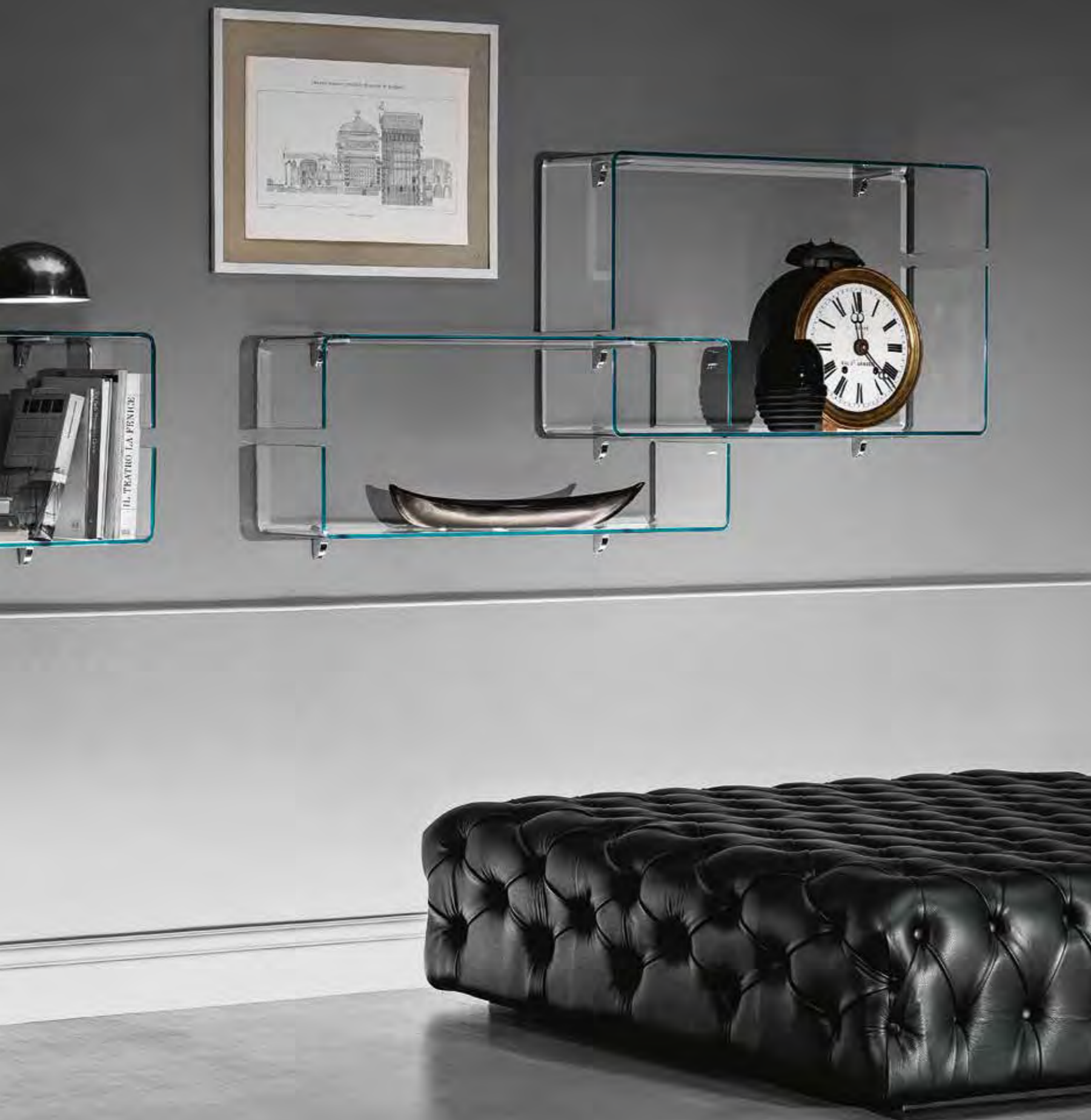

babila

design Luca Casini

Mensole in vetro curvato da 10 mm. Disponibili anche in vetro extralight. Reggimensola in metallo cromato.

Shelves in 10 mm-thick curved glass. Also available in extralight glass. Brackets in chromed metal.

Étagères en verre cintré de 10 mm. Disponible aussi en verre extralight. Support étagère en métal chromé.

Konsole aus 10 mm-starkem gebogenem Glas. Lieferbar auch aus extralight-Glas. Fachbodenträger aus verchromtem Metall.

Mensole in vetro extralight. Extralight glass shelves.

100 x 27 x 18,5 cm
39 3/8" x 10 5/8" x 7 5/16"

100 x 27 x 37 cm
39 3/8" x 10 5/8" x 14 9/16"



mensole rialto L

design CRS Fiam

Mensole in vetro curvato da 10 mm. Reggimensola in metallo cromato. Le mensole sono disponibili anche su misura con i seguenti limiti: lunghezza: da 65 cm a 190 cm; profondità: da 24 cm a 30 cm; altezza: fino a 36 cm per lunghezze entro i 100 cm e fino a 70 cm per lunghezze oltre i 100 cm. L'interasse massimo tra i reggimensola è di 70 cm.

Shelves in 10 mm-thick curved glass. Chromed metal bracket. Shelves are also available custom-sized with the following limits: length: from 65 cm to 190 cm; depth: from 24 cm to 30 cm; height: up to 36 cm for lengths up to 100 cm and up to 70 cm for lengths over 100 cm. The maximum gap between brackets is 70 cm.

Etagères en verre cintré de 10 mm. Supports d'étagère en métal chromé. Les étagères sont également disponibles sur mesure avec les limites suivantes: longueur: de 65 cm à 190 cm, profondeur: de 24 cm à 30 cm, hauteur: jusqu'à 36 cm pour les longueurs inférieures à 100 cm et jusqu'à 70 cm pour les longueurs supérieures à 100 cm. La distance maximale entre les supports d'étagère est de 70 cm.

Konsole aus 10 mm starkem, gebogenem Glas. Konsolehalterungen aus verchromtem Metall. Auch maßgefertigt lieferbar in Längen von 65 bis 190 cm, Tiefen von 24 bis 30 cm, Höhen bis 36 cm für Längen bis 100 cm, Höhen bis 70 cm für Längen über 100 cm. Maximaler Mittenabstand zwischen den Bordhalterungen 70 cm.

Mensole.
Shelves.

100 x 24 x 36 cm
39 3/8" x 9 7/16" x 14 3/16"
140 x 24 x 40 cm
55 1/8" x 9 7/16" x 15 3/4"





luminare cassettera

design CRS Fiam

Cassettera in legno laccato opaco nei colori bianco o nero. Disponibile con 3 o 4 cassetti. I frontali sono in vetro da 6 mm verniciati in abbinamento al colore della struttura. Disponibile anche con ruote piroettanti.

Drawer unit in white or black matt lacquered wood. Available with 3 or 4 drawers. The fronts are in 6 mm glass varnished to match the carcass colour. Also available with castors.

Meuble à tiroirs en bois laqué opaque dans les couleurs blanc ou noir. Disponible avec 3 ou 4 tiroirs. Les façades sont en verre de 6 mm et peintes dans la même teinte que la structure. Également disponible avec des roulettes pivotantes.

Schubladenelement aus matt lackiertem Holz in Weiß oder Schwarz. Mit 3 oder 4 Schubladen. Fronten aus 6 mm starkem, lackiertem Glas in der Korpusfarbe. Auch mit Lenkrollen.



Cassettiera.
Drawer unit.
45 x 48 x 70 cm
17 11/16" x 18 7/8" x 27 9/16"
45 x 48 x 54 cm
17 11/16" x 18 7/8" x 21 1/4"



rialto cassettera

design CRS Fiam

Cassettera in vetro curvato trasparente da 8 mm. La struttura dei cassetti è in legno laccato bianco. La cassettera è provvista di 2 cassetti con sistema di chiusura automatica soft. Ruote e maniglie cromate.

Drawer unit in 8 mm curved transparent glass. The drawers have white lacquered wood frame. The drawer unit features 2 drawers with automatic soft closure system. Chromed wheels and handles.

Meuble à tiroirs en verre cintré transparent de 8 mm. La structure des tiroirs est en bois laqué blanc. Le meuble à tiroirs est doté de 2 tiroirs avec système de fermeture automatique amortie. Roulettes et poignées chromées.

Kommode aus 8 mm starkem, transparentem, gebogenem Glas. Zargen der Schubladen aus weiß lackiertem Holz. 2 Schubladen mit automatischen Soft-Close-Einzug. Räder und Griffe verchromt.



Cassettiera.
Drawer unit.
48 x 45 x 67 cm
18 7/8" x 17 1/16" x 26 3/8"

L'idea di realizzare "miniature" dei prodotti storici FIAM Italia nasce nel 2000. L'intento è quello di proporre una collezione di opere in scala ridotta che testimoniano l'unicità del cristallo curvato oltre a dimostrare allo stesso tempo come tali opere, assunta una nuova veste e una nuova dimensione, possano continuare ad offrire un'alta carica espressiva capace di aggiungere bellezza, poesia ed un tocco di vita in più alle nostre case.

L'idée de réaliser des « miniatures » des produits historiques FIAM Italia est née en l'an 2000. L'intention était de proposer une collection de pièces à l'échelle réduite exprimant le caractère unique du cristal cintré et de démontrer que ces pièces, habillées d'une nouvelle présentation et d'une nouvelle dimension, pouvaient continuer à dégager une charge expressive en mesure d'ajouter de la beauté, de la poésie et une touche de vie à votre intérieur.

The idea of producing miniatures of FIAM Italia's most famous products dates from 2000. The aim was to offer a collection of works on a small scale that would illustrate the unique features of curved plate glass as well as proving that, even in a new form and size, these works still have a striking expressive charge, capable of adding beauty, poetry and a touch of extra life to our homes.

Die Idee, Miniaturmodelle dieser in die Geschichte des Designs eingegangenen Meisterwerke herzustellen, wurde bereits im Jahr 2000 geboren, mit der Absicht, eine Kollektion von maßstabgetreuen Modellen zu schaffen, die Zeugnis von der Einzigartigkeit des gebogenen Kristall-glases ablegen und gleichzeitig unter Beweis stellen, dass diese Meisterwerke auch in einer neuen Aufmachung und im Miniaturformat ihre ganze Ausdruckskraft beibehalten und unser Zuhause mit Schönheit, Poesie und einem Hauch von Leben bereichern.

mini collection

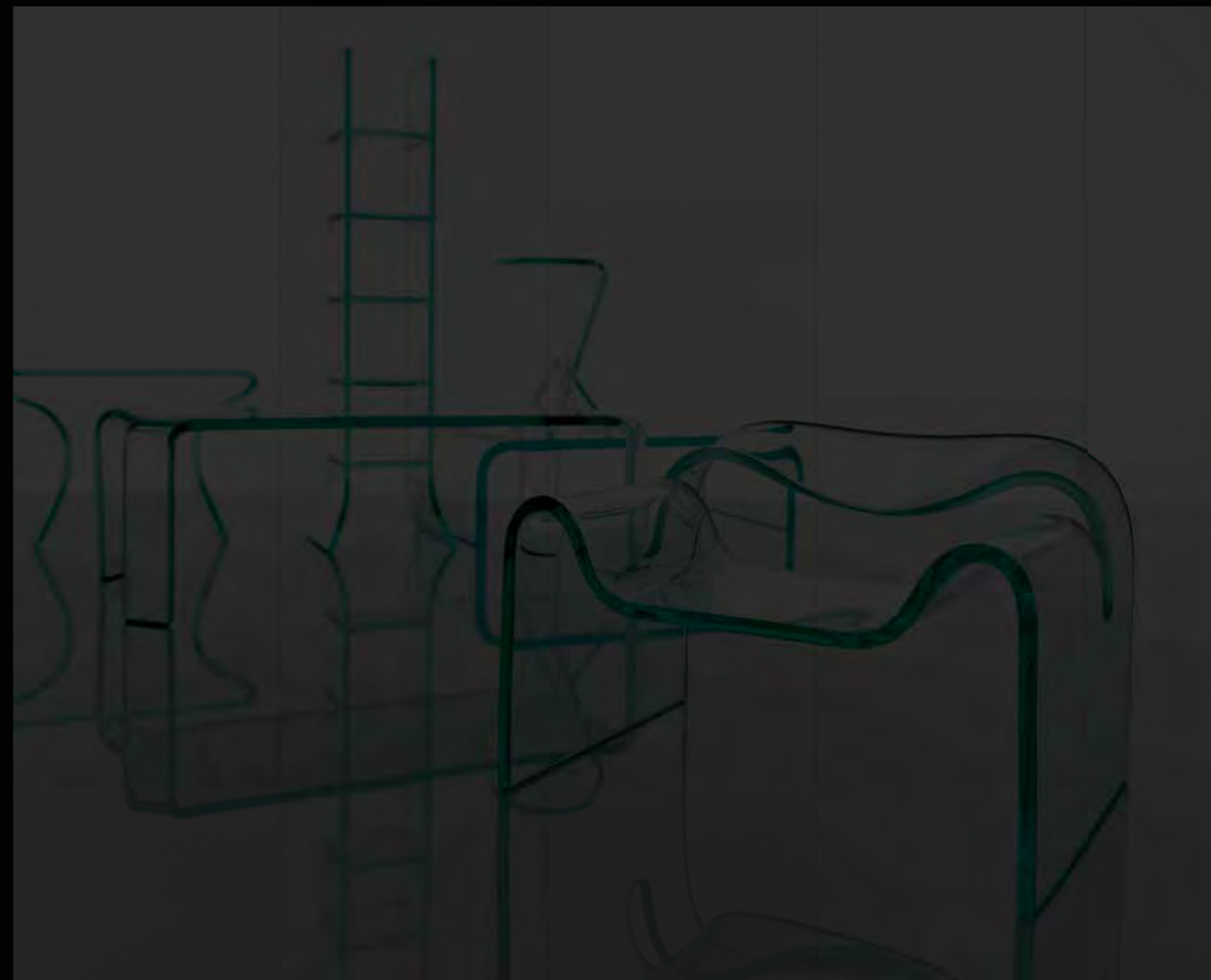

mini collection





ADMIRAL



ø 6 x 27 cm
ø 2 3/8" x 10 5/8"

BABELE



9 x 9 x 34 cm
3 9/16" x 3 9/16" x 13 3/8"

MANTA



23 x 14 x 7 cm
9" x 5 1/2" x 2 3/4"

CHARLOTTE



17 x 5,5 x 11 cm
6 1/16" x 2 3/16" x 4 5/16"

COBRA



7 x 8,5 x 14 cm
2 3/4" x 3 3/8" x 5 1/2"

GHOST



17,5 x 15,5 x 11 cm
6 7/8" x 6 1/8" x 4 5/16"

GRILLO



10,5 x 8 x 12 cm
4 1/8" x 3 1/8" x 4 3/4"

ALVAR AALTO



ø 9 x 10,5 cm
ø 3 9/16" x 4 1/8"

PONTE



26 x 14 x 8 cm
10 1/4" x 5 1/2" x 3 1/8"

RAGNO



30,5 x 16 x 10,5 cm
12" x 6 5/16" x 4 1/8"

I Customizzabili

The Customizables



I Customizzabili

The Customizables

Home Office



	BRIGHT	GRAPH	HYPE SCRITTOIO	LLT (HOME OFFICE, OFX EXECUTIVE)	RIALTO (L, WALL MOUNTED, ISOLA)
Misure H. - P. - L. Dimensions H. - W. - L.	•			•	•
Dimensione del Top Top dimension	•		•	•	
Finiture vetro Glass finish	•	•			
Laccatura Lacquering	•	•	•	•	•

tavoli meeting

meeting tables



	LLT OFX MEETING	LUXOR
Misure H. - P. - L. Dimensions H. - W. - L.	•	•
Dimensione del Top Top dimension	•	•
Finiture vetro Glass finish		•
Laccatura Lacquering	•	•

sistemi, mensole

systems, shelves



	INORI	BABILA	MENSOLE RIALTO L
Misure H. - P. - L. Dimensions H. - W. - L.	•		•
Finiture vetro Glass finish	•	•	•
Laccatura Lacquering	•		

Schede tecniche

Technical data

SCRIVANIE	bright	124
DESKS	graph	125
	hype scrittoio	126
	LLT home office	128
	LLT ofx executive	129
	rialto isola	130
	rialto L	131
	rialto L wall mounted	132
	rialto scrivania	133
TAVOLI RIUNIONI	LLT ofx meeting	134
MEETING TABLES	luxor	136
LIBRERIE,	babila	138
MENSOLE,	inori	142
CASSETTIERE	inori freestanding	142
BOOKSHELVES,	luminare cassettera	146
SHELVES,	mensole rialto L	140
DRAWER UNITS	rialto cassettera	147

Schede tecniche

Technical data

bright

design Valerio Cometti

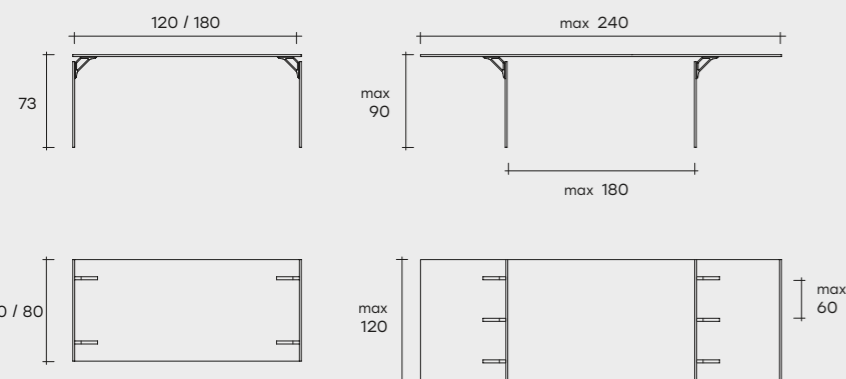
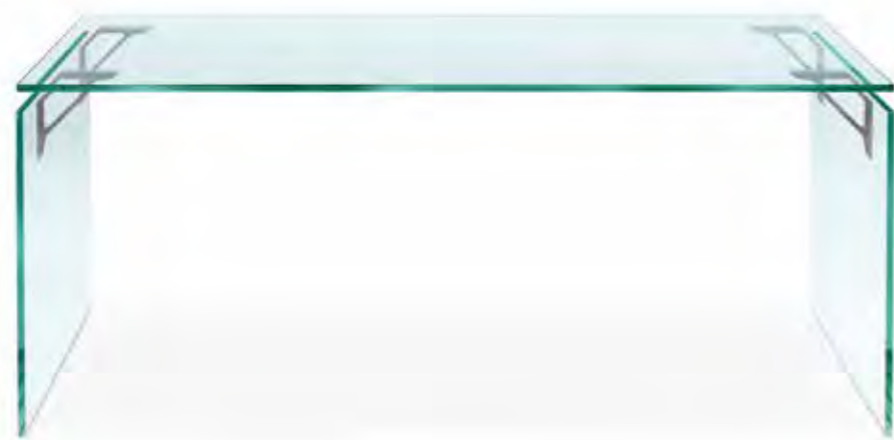

Scrivania in vetro temperato da 15 mm smontabile con supporti di fissaggio in alluminio ed acciaio. Disponibile anche su misura.

Desk in 15 mm-thick tempered glass with aluminium and steel mounting supports. Also available custom-sized.

Bureau en verre trempé et soudé de 15 mm. Supports de fixation en aluminium et acier, démontables. Également disponible sur mesure.

120 x 60 x 73 cm
47 1/4" x 23 5/8" x 28 3/4"
130 x 60 x 73 cm
51 3/16" x 23 5/8" x 28 3/4"
140 x 70 x 73 cm
55 1/8" x 27 9/16" x 28 3/4"
160 x 70 x 73 cm
62" x 27 9/16" x 28 3/4"
180 x 80 x 73 cm
70 7/8" x 31 1/2" x 28 3/4"

Schreibtisch aus 15 mm starkem, gehärtetem Glas. Zerlegbare Aluminium und Stahl-Befestigungselementen. Auch als Maßanfertigung lieferbar.

graph

design Xavier Lust

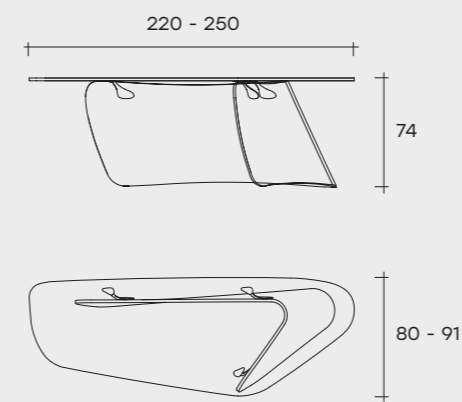

Scrivania composta da base in vetro trasparente curvato da 19 mm e piano in vetro trasparente da 15 mm temperato con piastre di aggancio in acciaio inox.

Desk comprising base in 19 mm-thick curved transparent glass and 15 mm-thick tempered transparent glass top with stainless steel connecting plates.

Bureau composé d'une base en verre transparent cintré de 19 mm et d'un plateau en verre transparent de 15 mm avec plaques de fixation en acier inoxydable.

Desk comprising base in 19 mm-thick curved transparent glass and 15 mm-thick tempered transparent glass top with stainless steel connecting plates.

220 x 80 x 74 cm
86 5/8" x 31 1/2" x 29 1/8"
250 x 91 x 74 cm
90 7/16" x 35 13/16" x 29 1/8"

hype

design Studio Klass



Piano in vetro fuso retroverniciato _ Back-painted fused glass top

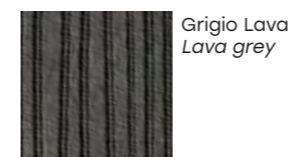

Grigio Lava
Lava grey

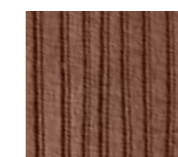

Marrone ramato
Copper brown



Champagne
Champagne

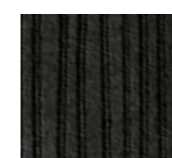

Nero Brillante
Brilliant Black

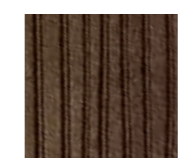

Marrone Brillante
Brilliant Brown

Base in metallo _ Metal base



Grigio Lava
Lava Grey

120 x 60 x 75 cm
47 1/4" x 23 5/8" x 29 1/2"

160 x 60 x 75 cm
63" x 23 5/8" x 29 1/2"

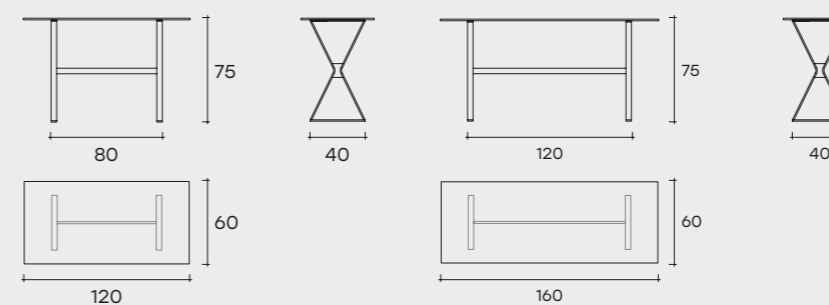

Scrivania con piano in vetro da 12 mm fuso a gran fuoco, temperato e retroverniciato con tinte metallizzate. Base in metallo verniciato, finitura Grigio Lava.

Desk with 12 mm fused, tempered and backlacquered glass top with metallic paints. Painted metal base, "Lava Grey" finish.

Bureau avec plateau en verre en fusion de 12 mm, trempé et verni dessous avec des teintes métallisées. Base en métal verni, finition Gris Lave.

Konsole mit Platte aus geschmolzenem und gehärtetem Glas 12mm mit Metallfarben unterlackiert. Untergestell aus Metall in der Farbvariante Lavagrau.

LLT home office

design Dante O. Benini
e Luca Gonzo

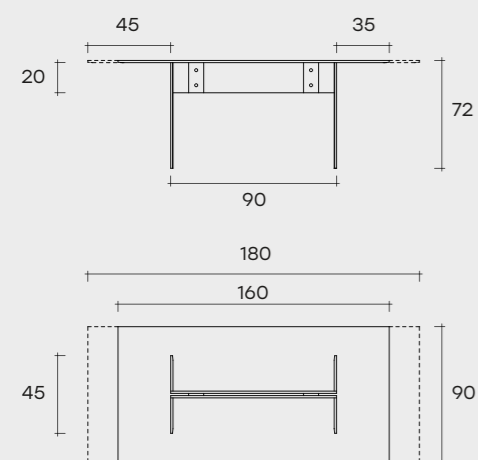

160 x 70 x 72 cm
62" x 27 9/16" x 28 3/8"
180 x 80 x 72 cm
70 7/8" x 31 1/2" x 28 3/8"

Scrivania con piano in vetro trasparente da 15 con bisellatura su due lati corti, struttura gambe in vetro trasparente saldato da 15 mm con bisellatura sul bordo. Particolari di fissaggio in acciaio inox. Disponibile anche con piani su misura.

Desk composed of a 15 mm thick transparent glass top with bevelled edges on the two shorter sides and of a base in 15 mm thick transparent welded glass with bevelled edge. Fastening elements in stainless steel. Also available with tops of customized size.

Bureau se composant d'un plateau en verre transparent de 15 mm avec biseautage sur les deux côtés courts et d'un piétement en verre transparent soudé, épaisseur 15 mm, avec bords biseautés. Éléments de fixation en acier inoxydable. Également disponible avec plateau sur mesure.

Schreibtisch mit Platte aus transparentem 15 mm starkem Glas, Facettenschliff auf den zwei kürzeren Seiten. Untergestell aus transparentem 15 mm starkem verschweisstem Glas, Facettenschliff auf den Kanten. Verbindungselemente aus Edelstahl. Auch mit Maßgefertigter Platte.

LLT ofx executive

design Dante O. Benini
e Luca Gonzo

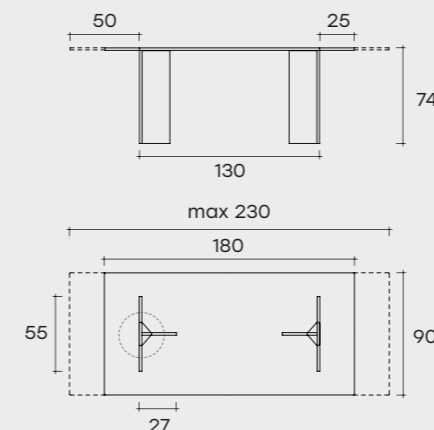

Collezione di scrivanie direzionali in vetro trasparente da 19 mm. Il piano è appoggiato sulle basi in vetro saldato e i fori presenti hanno la funzione di passacavi. LLT ofx executive è disponibile anche con piani su misura, fino ad una lunghezza di 260 cm.

Collection of executive desks in 19 mm thick transparent glass. The top rests on the bases in welded transparent glass and is equipped with cable entry holes. LLT ofx executive is also available with custom-sized top up to 260 cm length.

Collection des bureaux se composant d'un plateau en verre transparent de 19 mm et d'un piétement en verre transparent soudé. Trous pour le passage des cables. Disponible avec plateau sur mesure jusqu'à une longueur de cm 260.

180 x 90 x 74 cm
70 7/8" x 35 7/16" x 29 1/8"
260 x 90 x 74 cm
102 3/8" x 35 7/16" x 29 1/8"

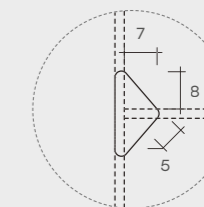

Kollektion von Schreibtischen Besprechungstisch mit Platte aus transparentem 19 mm starkem Glas, und Untergestell aus transparentem 19 mm starkem verschweisstem Glas. Kabelführungslöcher. Auch mit Maßgefertigter Platte erhältlich bis max. Länge von 260 cm.

rialto isola

design CRS Fiam



rialto L

design CRS Fiam

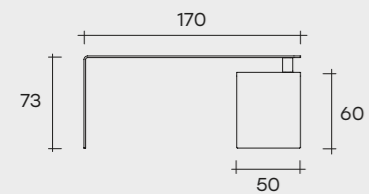

Piano principale / Main top:
170 x 70 x 73 cm
67" x 27 9/16" x 28 3/4"

Piano di servizio / Side shelf:
140 x 50 x 60 cm
55 1/8" x 19 11/16" x 23 5/8"

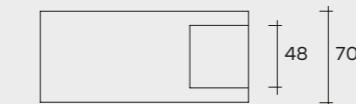
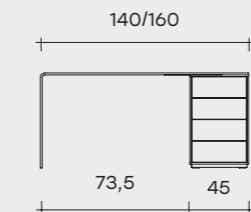
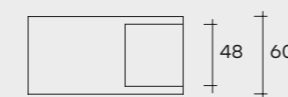
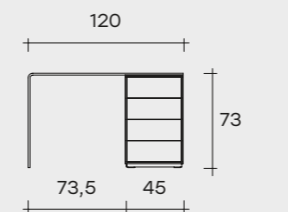

120 x 60 x 73 cm
47 1/4" x 23 5/8" x 28 3/4"

140 x 70 x 73 cm
55 1/8" x 27 9/16" x 28 3/4"

160 x 70 x 73 cm
63" x 27 9/16" x 28 3/4"

Scrivania composta da un ripiano principale e da un ripiano di servizio in vetro trasparente curvato da 15 mm sul lato sinistro. Particolari in alluminio brillantato. Disponibile anche su misura. Il ripiano di servizio può essere collocato a destra o sinistra senza sovrapprezzo, specificandolo all'ordine. Cassettiera non inclusa nel prezzo.

Desk comprising a main top and a shelf in curved 15 mm transparent glass on the left side. Details in gloss aluminium. Also available custom-sized. The shelf under the main top can be positioned on the left or on the right side without surcharge, by specifying it into the order. Drawer unit not included.

Bureau constitué d'un plateau principal et d'un plateau de service en verre transparent cintré de 15 mma gauche. Détails en aluminium brillanté. Egalement disponible sur mesure. L'étagère de service peut être positionné à gauche ou à droite sans supplément de prix mais seulement en le spécifiant sur la commande. Le caisson n'est pas inclus.

Schreibtisch mit Querplatte aus 15 mm starkem, gebogenem, transparentem Glas links. Details aus poliertem Aluminium. Auch Maßanfertigungen möglich. Das Fachboden kann sowohl rechst oder links ohne Aufpreis aber nur ab Bestellung ausgestellt werden. Kommode nicht enthalten.

Scrivania in vetro curvato da 15 mm, abbinata a cassetteria in legno laccato opaco nei colori bianco o nero con frontali in vetro verniciati in abbinamento al colore della struttura. Disponibile anche su misura.

Desk in 15 mm-thick curved glass combined with drawer unit in white or black matt lacquered wood, with fronts in glass varnished to match the structure colour. Customized Rialto desk available on demand.

Bureau en verre cintré à tiroirs en bois laqué opaque dans les coloris blanc ou noir, avec façades en verre vernies de couleur assortie à la structure. Egalement disponible sur mesure.

Schreibtisch aus 15 mm starkem gebogenem Glas, kombiniert mit Schubladenelement aus matt lackiertem Holz in Weiß oder Schwarz. Fronten aus farblich zum Korpus passend lackiertem Glas. Auch als Maßanfertigung lieferbar.

rialto L wall mounted

design CRS Fiam



rialto scrivania

design CRS Fiam

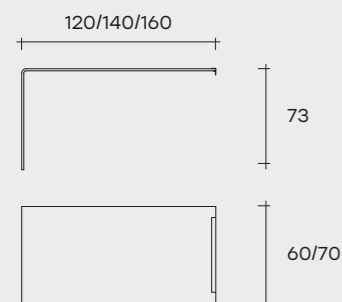

120 x 60 x 73 cm
47 1/4" x 23 5/8" x 28 3/4"
140 x 70 x 73 cm
55 1/8" x 27 9/16" x 28 3/4"
160 x 70 x 73 cm
63" x 27 9/16" x 28 3/4"

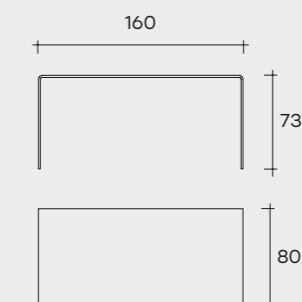
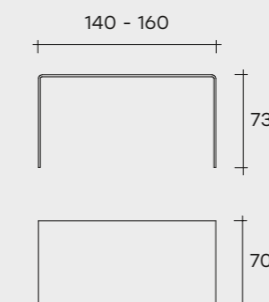
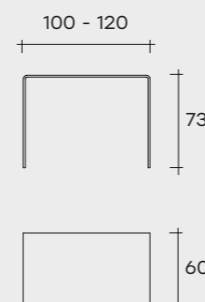

100 x 60 x 73 cm
39 3/8" x 23 5/8" x 28 3/4"
120 x 60 x 73 cm
47 1/4" x 23 5/8" x 28 3/4"
140 x 70 x 73 cm
55 1/8" x 27 9/16" x 28 3/4"
160 x 70 x 73 cm
63" x 27 9/16" x 28 3/4"
160 x 80 x 73 cm
63" x 31 1/2" x 28 3/4"

Scrivania in vetro trasparente curvato da 15 mm con una doppia piastra in alluminio brillantato per fissaggio a parete. Disponibile anche su misura.

Desk in 15 mm-thick transparent curved glass with a double bright-finish aluminium plate for wall-mounting. Customized Rialto desk available on demand.

Bureau en verre transparent cintré de 15 mm, assorti à une double plaque en aluminium poli pour fixation murale. Egalement disponible sur mesure.

Schreibtisch aus 15 mm starkem, transparentem, gebogenem Glas, kombiniert mit einer doppelten Leiste aus poliertem Aluminium zur Befestigung an der Wand. Auch als Maßanfertigung lieferbar.

Collezione di scrivanie in vetro curvato da 15 mm disponibili in varie misure. Su richiesta: profili in alluminio brillantato. Disponibile anche su misura.

Collection of desks in 15 mm curved glass, available in various sizes. On request: strips in polished aluminium. Also available custom-sized.

Collection de bureaux en verre cintré de 15 mm disponibles dans plusieurs dimensions. Sur demande: profils en aluminium brillanté. Egalement disponible sur mesure.

Kollektion von Schreibtischen aus 15 mm starkem gebogenem Glas in diversen Abmessungen. Auf Wunsch: geglänzte Aluminiumprofile. Auch als Maßanfertigung lieferbar.

LLT ofx meeting

design Dante O. Benini - Luca Gonzo



350 x 120 x 74 cm
137 13/16" x 47 1/4" x 29 1/8"

Tavolo riunioni in vetro trasparente da 19 mm. Il piano è appoggiato sulle basi in vetro incollato e i fori presenti hanno la funzione di passacavi. LLT ofx meeting è disponibile anche con piani su misura, fino ad una dimensione massima 350x120 cm.

Meeting table in 19 mm thick transparent glass. The top rests on the bases in glued transparent glass and is equipped with cable entry holes. LLT ofx meeting is also available with custom-sized top up to 350x120 cm.

Table de réunion se composant d'un plateau en verre transparent de 19 mm et d'un piétement en verre transparent soudé avec des trous pour le passage des cables. Disponible avec plateau sur mesure jusqu'à 350x120 cm.

Besprechungstisch mit Platte aus transparentem 19 mm starkem Glas, und Untergestell aus transparentem 19 mm starkem verschweisstem Glas. Kabelführungslöcher. Auch mit Maßgefertigter Platte erhältlich bis max. 350x120 cm.

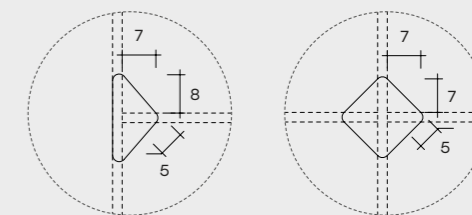
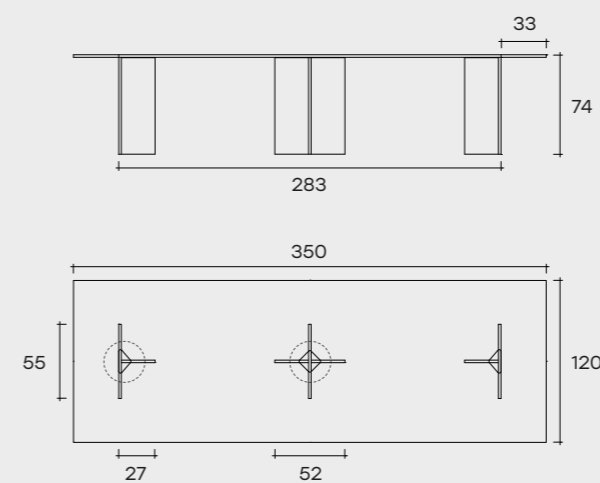

luxor

design Rodolfo Dordoni



Base in vetro curvato _ Curved glass base



Trasparente
Transparent



Extralight
Extralight



Fumé
Smoked

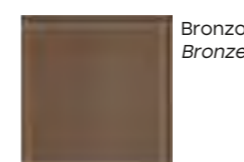

Bronzo
Bronze

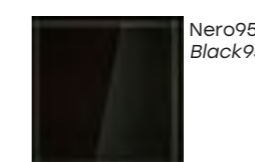

Nero95
Black95



Extralight
retroverniciato bianco
White back-painted
extralight

150 x 150 x 75 cm
59 1/16" x 59 1/16" x 29 1/2"
220 x 110 x 75 cm
86 5/8" x 43 5/16" x 29 1/2"
240 x 120 x 75 cm
94 1/2" x 47 1/4" x 29 1/2"

Dimensioni custom
Custom dimensions
Dimensions custom
Custom Abmessungen

350 x 120 x 74 cm
137 13/16" x 47 1/4" x 29 1/8"

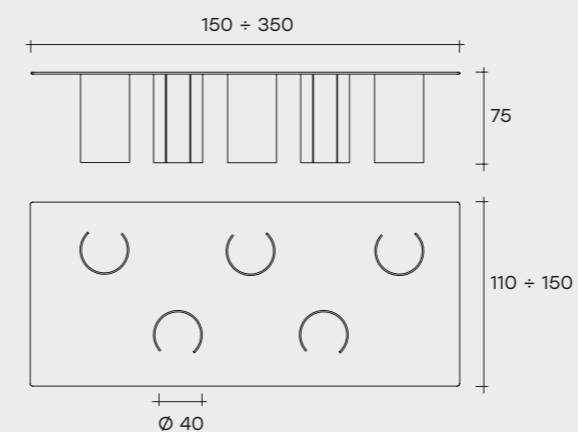

Tavolo con piano in vetro fumé o bronzo stratificato da 8+8 mm finitura filo lucido tondo, disponibile anche in vetro trasparente o extralight. A seconda della misura e della configurazione desiderata base composta da 2, 3 o 4 cilindri (Ø 40 cm) in vetro da 10 mm, disponibile fumé, bronzo trasparente o extralight. Disponibile anche con piani a misura.

Table with layered glass top 8+8 mm-thick brilliant polished rim, in smoked or bronze glass also available in transparent glass or extralight glass. 10 mm-thick curved glass base, composed of 2, 3 or 4 cylinders (Ø 40 cm) depending upon the size and the shape requested. Bases are available in smoked glass, bronze glass, transparent glass or extralight glass. Also available with tops of customized size.

Table avec plateau en verre feuilleté de 8+8 mm fumé ou bronze finition chant poli arrondi, ou en verre trempé transparent ou extralight. Base en verre cintré de 10 mm se composant de 2, 3 ou 4 cylindres (Ø 40 cm) dépendant de la mesure ou de la configuration désirée. Disponible en verre fumé, en verre bronze, en verre transparent ou en verre extralight. La table Luxor est également disponible avec de dessus sur mesure.

Tisch mit 8+8 mm-starker Schichtglasplatte in Rauch- oder Bronze-Glas oder in transparentem bzw. extralight gehärtetem Glas. Untergestell bestehend aus 2, 3 bzw. 4 Zylindern (Durchmesser 40 cm) abhängig von den gewünschten Massen und Gestaltung, aus 10 mm starkem gebogenem Glas, lieferbar in den Ausführungen Rauchglas, oder Bronzeglas, transparentes bzw. extralight Glas. Auch mit maßgefertigter Platte lieferbar.

babila

design Luca Casini

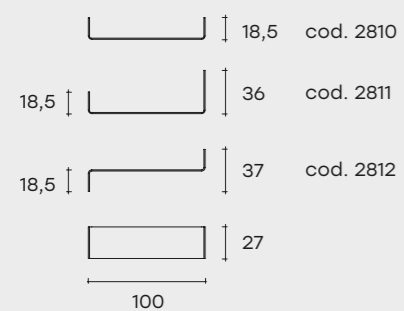

100 x 27 x 18,5 cm
 39 3/8" x 10 5/8" x 7 5/16"

100 x 27 x 36 cm
 39 3/8" x 10 5/8" x 14 3/16"

100 x 27 x 37 cm
 39 3/8" x 10 5/8" x 14 9/16"

POSSIBILI POSIZIONI / POSSIBLE POSITIONS

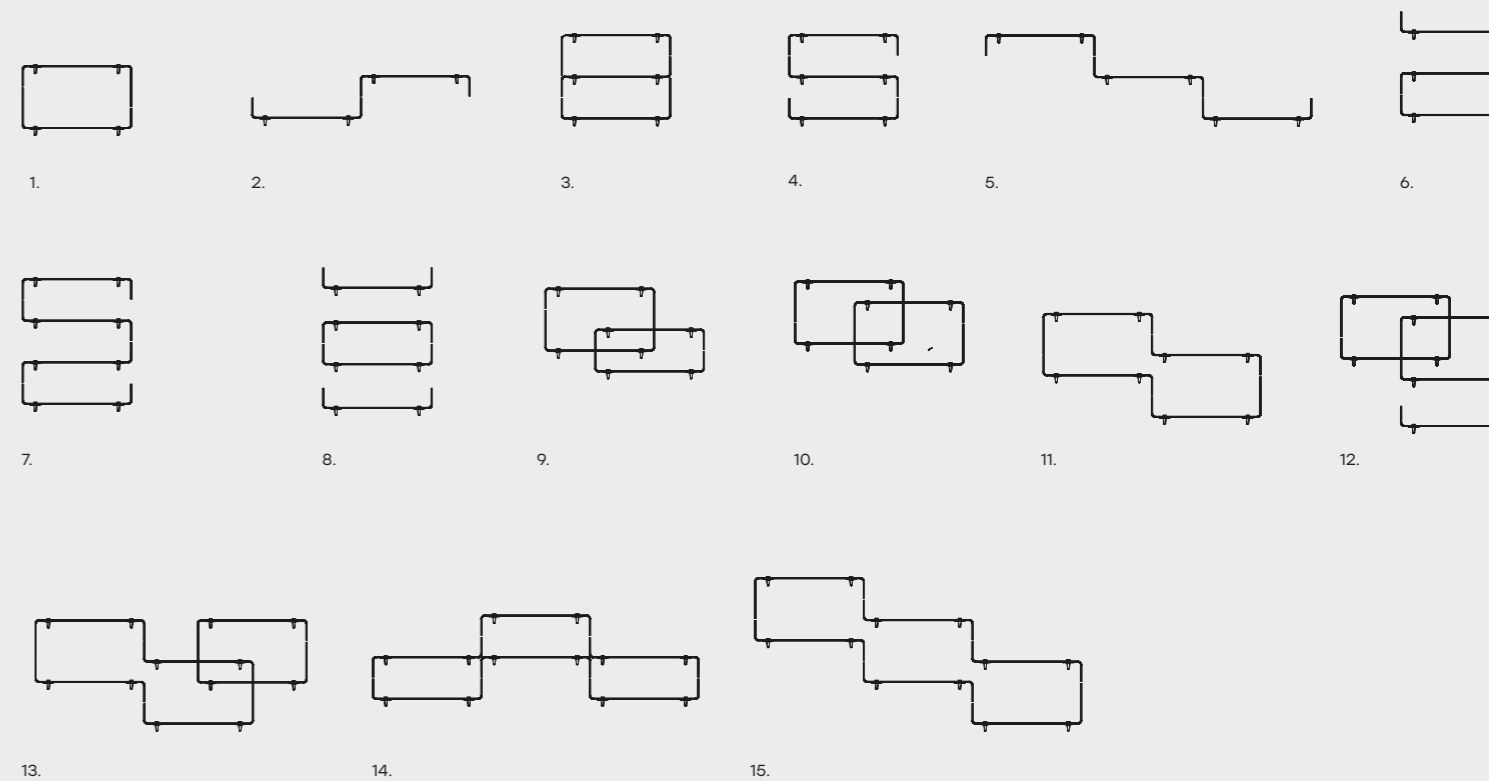

Mensola in vetro curvato da 10 mm.

Shelf in 10 mm-thick curved glass.

Etagères en verre cintré de 10 mm.

Konsole aus 10 mm-starkem gebogenem Glas.

mensole rialto L

design CRS Fiam



190 x 30 x 40 cm
74 13/16" x 11 13/16" x 15 3/4"

140 x 24 x 40 cm
55 1/8" x 9 7/16" x 15 3/4"

100 x 24 x 36 cm
39 3/8" x 9 7/16" x 14 3/16"

65 x 24 x 30 cm
25 9/16" x 9 7/16" x 11 13/16"

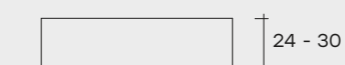
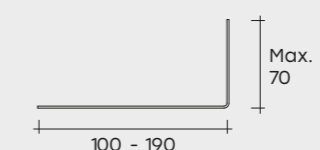
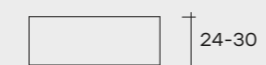
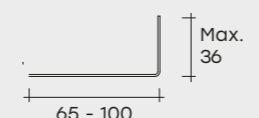

Mensole in vetro curvato da 10 mm. Reggimensola in metallo cromato. Le mensole sono disponibili anche su misura con i seguenti limiti: lunghezza: da 65 cm a 190 cm; profondità: da 24 cm a 30 cm; altezza: fino a 36 cm per lunghezze entro i 100 cm e fino a 70 cm per lunghezze oltre i 100 cm. L'interasse massimo tra i reggimensola è di 70 cm.

Shelves in 10 mm-thick curved glass. Chromed metal bracket. Shelves are also available custom-sized with the following limits: length: from 65 cm to 190 cm; depth: from 24 cm to 30 cm; height: up to 36 cm for lengths up to 100 cm and up to 70 cm for lengths over 100 cm. The maximum gap between brackets is 70 cm.

Etagères en verre cintré de 10 mm. Supports d'étagère en métal chromé. Les étagères sont également disponibles sur mesure avec les limites suivantes: longueur: de 65 cm à 190 cm, profondeur: de 24 cm à 30 cm, hauteur: jusqu'à 36 cm pour les longueurs inférieures à 100 cm et jusqu'à 70 cm pour les longueurs supérieures à 100 cm. La distance maximale entre les supports d'étagère est de 70 cm.

Konsole aus 10 mm starkem, gebogenem Glas. Konsolehalterungen aus verchromtem Metall. Auch maßgefertigt lieferbar in Längen von 65 bis 190 cm, Tiefen von 24 bis 30 cm, Höhen bis 36 cm für Längen bis 100 cm, Höhen bis 70 cm für Längen über 100 cm. Maximaler Mittenabstand zwischen den Bordhalterungen 70 cm.

POSSIBILI POSIZIONI / POSSIBLE POSITIONS

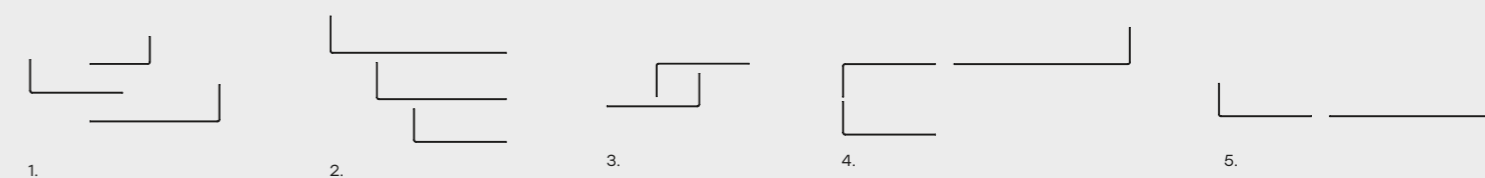

inori & inori freestanding

design Setsu & Shinobu Ito



Montanti / Uprights

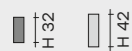

Basi / Bases

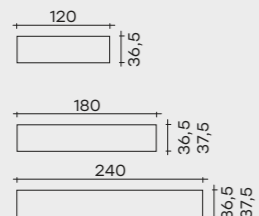

Ripiani / Shelves

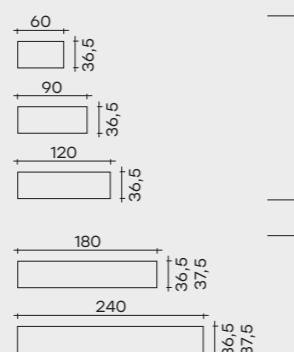

Disponibili solo nelle finiture vetro
In glass versions only
Pour les étagères en verre uniquement
Für die Glasfachböden nur

Disponibili in tutte le finiture
In all finishings
Pour toutes finitions
Für alle Finish

Sistema composto da elementi in vetro o legno modulari. La modularità e versatilità ne permette l'utilizzo come libreria, espositore, contenitore porta tv, sviluppabili sia in situazioni con fissaggio a muro che autoportanti. Tutti i montanti sono liberamente posizionabili tramite sistema di ancoraggio e scorrimento a binario applicato su ogni singolo ripiano. Binario in alluminio anodizzato nero.

Modular book shelves glass or wood system. The versatility and assembly possibilities allow the utilization as a show-case, display-case, TV-unit. Available the free-standing version and wall unit. The uprights are freely adjustable on each shelf through sliding rails and fixing device. Slides in anodized black aluminum.

Système composé d'éléments modulables en verre ou en bois. Sa modularité et sa versatilité permettent l'utilisation comme bibliothèque, présentoir, conteneur, portes-TV dans les versions soit appuyantes au sol soit accrochables au mur. Tous les montants sont positionnables avec un système de fixation et rail appliqué sur chaque étagère. Rail en aluminium anodisé noir.

System aus modularen Glas-oder Holz-Elementen. Vielseitig einsetzbar und beliebig kombinierbar, als Bücherregal, Ausstellungsregal, TV-Element usw. Verschiedene Kombinationen sind möglich, als freistehende Ausführung bzw. als Wandregal. Die Stützen sind frei verstellbar auf jedem Fachboden durch Führung und Befestigungsmodul. Laufschiene aus schwarzem eloxiertem Aluminium.

Base in legno _ Wood base

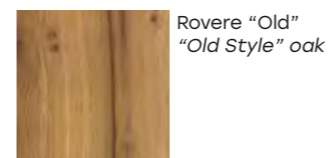

Rovere "Old"
"Old Style" oak



Noce canaletto
finitura tabacco
Canaletto walnut
tobacco finish



Noce termotrattato
nero
Heath-treated black
finish walnut

Base in vetro _ Glass base



Vetro extralight
retroverniciato bianco
Extralight white
back-painted glass

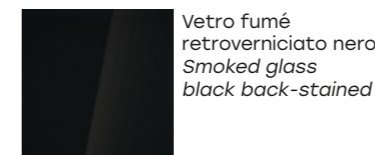

Vetro fumé
retroverniciato nero
Smoked glass
black back-stained

Ripiano in legno _ Wood shelf

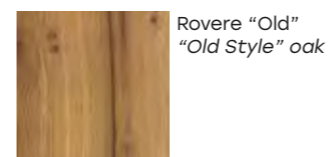

Rovere "Old"
"Old Style" oak



Noce canaletto
finitura tabacco
Canaletto walnut
tobacco finish

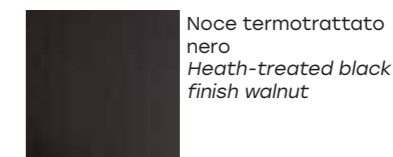

Noce termotrattato
nero
Heath-treated black
finish walnut

Ripiano in vetro _ Glass shelf



Vetro trasparente
Transparent glass



Vetro extralight
Extralight glass

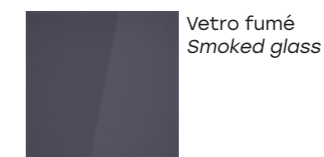

Vetro fumé
Smoked glass

Montante in vetro curvato _ Curved glass upright



Vetro trasparente
Transparent glass



Vetro extralight
Extralight glass

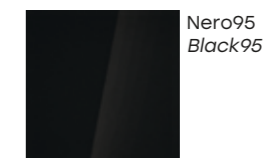

Nero95
Black95

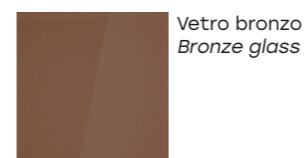

Vetro bronzo
Bronze glass

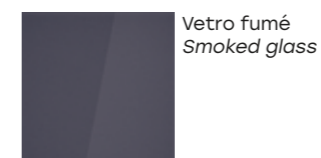

Vetro fumé
Smoked glass

Tutti i montanti sono liberamente posizionabili tramite sistema di ancoraggio e scorrimento a binario applicato su ogni singolo ripiano. Binario in alluminio anodizzato nero.
The uprights are freely adjustable on each shelf through sliding rails and fixing device. Slides in anodized black aluminum.
Tous montants sont positionnables avec un système de fixation et rail appliqué sur chaque étagère. Rail en aluminium anodisé noir.
Die Stützen sind frei verstellbar auf jedem Fachboden durch Führung und Befestigungsmodul. Laufschiene aus schwarzem eloxiertem Aluminium.



Alcuni suggerimenti tra le infinite soluzioni _ Just a few of the numerous solutions
Quelques suggestions parmi de nombreuses possibilités _ Einige Vorschläge zu unzähligen Lösungen

Libreria _ Bookcase _ Bibliothèque _ Bücherregal

Montanti / Uprights
Montants / Stütze

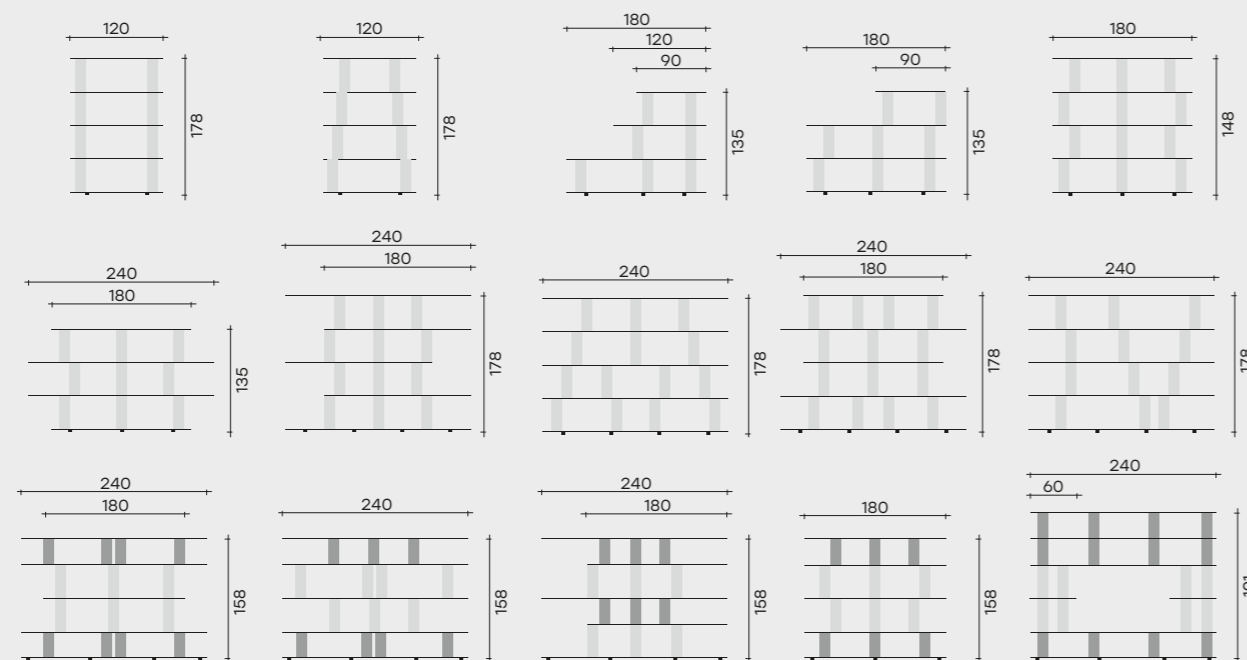
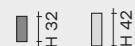

Porta TV _ Tv unit _ Porte-TV _ TV-Ständer

Montanti / Uprights
Montants / Stütze

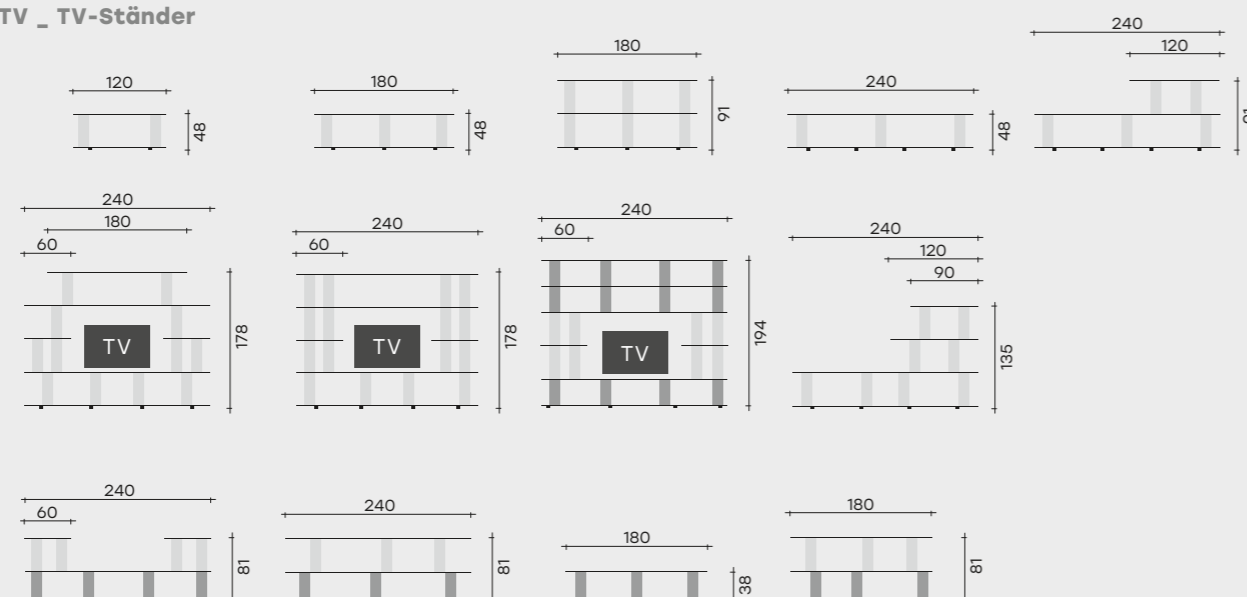

Consolle _ Console _ Console _ Konsole

Montanti / Uprights
Montants / Stütze



Retro divano _ Sofa back sideboard _ Bout de Canape _ Sofa Hinterelement

Montanti / Uprights
Montants / Stütze

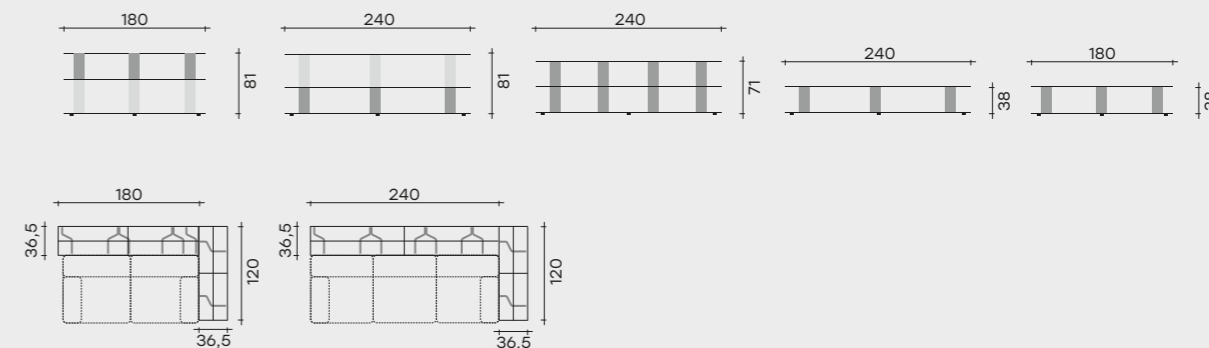

Mobile basso _ Low unit _ Meubles bas _ Kleinmöbel

Montanti / Uprights
Montants / Stütze

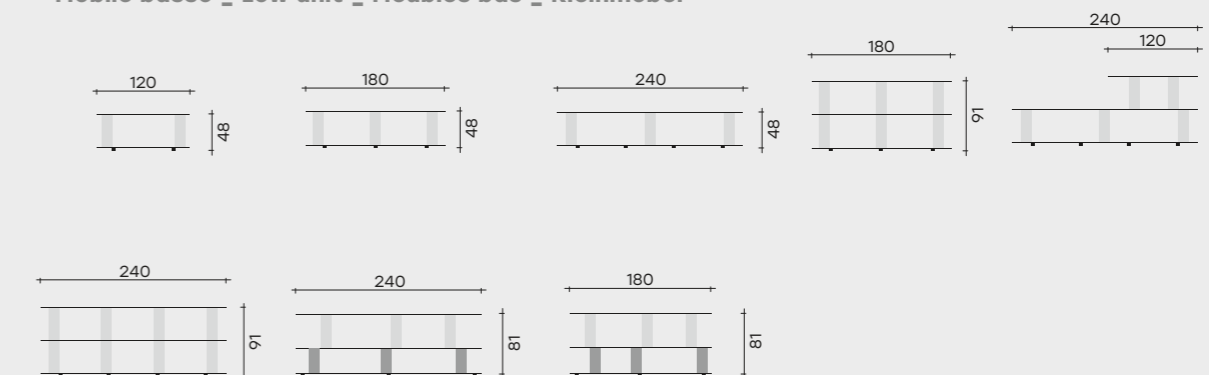

Soluzione centrostanza _ Room centrepiece solution _ Solution en séparation de pièces _ Zimmermitte-Lösung

Montanti / Uprights
Montants / Stütze

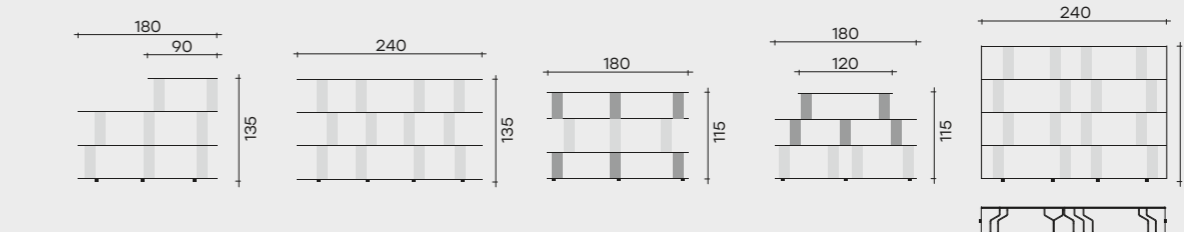

Altezza massima per le strutture autoportanti:

- Su basi di lunghezza 120 cm: h max 48 cm (vetro) o 51 cm (legno).
- Su basi di lunghezza 180 cm: h max 135 cm (vetro) o 143 cm (legno).
- Su basi di lunghezza 240 cm: h max 178 cm (vetro) o 189 cm (legno) con accessorio dedicato.

Altezza massima per le strutture con ancoraggio a muro:

- Massimo 5 ripiani in vetro, 6 ripiani in legno, base esclusa.

Distance massima tra i montanti: 130 cm.

Max. height of the free-standing version:

- With base length 120 cm: h max 48 cm (glass) or 51 cm (wood).
- With base length 180 cm: h max 135 cm (glass) or 143 cm (wood).
- With base length 240 cm: h max 178 cm (glass) or 189 cm (wood) with accessories.

Max. height of the wall version:

- Max 5 glass shelves, max 6 wood shelves, base excluded.

Max. distance between the uprights: 130 cm.

Hauteur maxi. pour les structures posées au sol:

- Avec base de longueur 120 cm: h max 48 cm (verre) ou 51 cm (bois).
- Avec base de longueur 180 cm: h max 135 cm (verre) ou 143 cm (bois).
- Avec base de longueur 240 cm: h max 178 cm (verre) ou 189 cm (bois) avec accessoires.

Hauteur maxi. pour les structures accrochables au mur:

- Avec max 5 étagères en verre, max 6 étagères en bois, base excluse.

Distance maxi entre les montants: 130 cm.

Max. Höhe der Standausführung:

- Mit Basislänge 120 cm: h max 48 cm (Glas) or 51 cm (Holz).
- Mit Basislänge 180 cm: h max 135 cm (Glas) or 143 cm (Holz).
- Mit Basislänge 240 cm: h max 178 cm (Glas) or 189 cm (Holz) mit Accessoires.

Max. Höhe der Wandausführung:

- Mit max 5 Glasfachböden, max 6 Holzfachböden, ohne die Basis.

Max. Abstand zwischen den Stützen: 130 cm.

luminare cassettiera

design CRS Fiam



Struttura in legno laccato
Lacquered wood structure

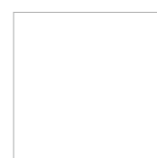

Bianco
White



Nero
Black

Frontale cassetto in vetro retroverniciato
Back-painted glass drawer front



Bianco
White



Nero
Black

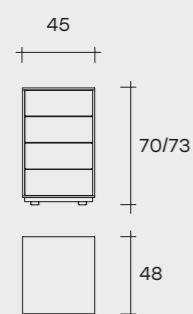
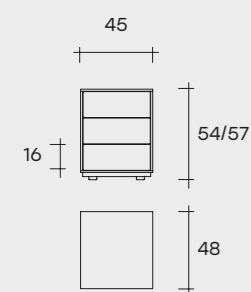

45 x 48 x 54 cm
17 11/16" x 18 7/8" x 21 1/4"

45 x 48 x 57 cm
17 11/16" x 18 7/8" x 22 7/16"
con ruote, with castors
avec roulettes, mit Lenkrollen

45 x 48 x 70 cm
17 11/16" x 18 7/8" x 27 9/16"

45 x 48 x 73 cm
17 11/16" x 18 7/8" x 28 3/4"
con ruote, with castors
avec roulettes, mit Lenkrollen

Cassettiera in legno laccato opaco nei colori bianco o nero. Disponibile con 3 o 4 cassetti. I frontali sono in vetro da 6 mm verniciati in abbinamento al colore della struttura. Disponibile anche con ruote piroettanti.

Drawer unit in white or black matt lacquered wood. Available with 3 or 4 drawers. The fronts are in 6 mm glass varnished to match the carcass colour. Also available with castors.

Meuble à tiroirs en bois laqué opaque dans les coloris blanc ou noir. Disponible avec 3 ou 4 tiroirs. Les façades sont en verre de 6 mm et peintes dans la même teinte que la structure. Également disponible avec des roulettes pivotantes.

Schubladenelement aus matt lackiertem Holz in Weiß oder Schwarz. Mit 3 oder 4 Schubladen. Fronten aus 6 mm starkem, lackiertem Glas in der Korpusfarbe. Auch mit Lenkrollen.

rialto cassettiera

design CRS Fiam

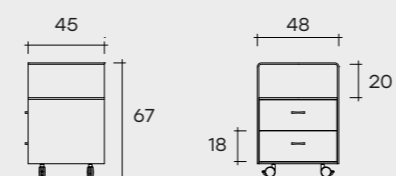

48 x 45 x 67 cm
18 7/8" x 17 11/16" x 26 3/8"

Cassettiera in vetro curvato trasparente da 8 mm. La struttura dei cassetti è in legno laccato bianco. La cassetiera è provvista di 2 cassetti con sistema di chiusura automatica soft. Ruote e maniglie cromate.

Drawer unit in 8 mm curved transparent glass. The drawers have white lacquered wood frame. The drawer unit features 2 drawers with automatic soft closure system. Chromed wheels and handles.

Meuble à tiroirs en verre cintré transparent de 8 mm. La structure des tiroirs est en bois laqué blanc. Le meuble à tiroirs est doté de 2 tiroirs avec système de fermeture automatique amortie. Roulettes et poignées chromées.

Kommode aus 8 mm starkem, transparentem, gebogenem Glas. Zargen der Schubladen aus weiß lackiertem Holz. 2 Schubladen mit automatischen Soft-Close-Einzug. Räder und Griffe verchromt.

FIAM è certificata UNI EN ISO 9001; la conformità a questa norma di riferimento permette a FIAM di raggiungere altissimi standard qualitativi. Una delle testimonianze dirette è la rintracciabilità dei suoi manufatti: ogni prodotto FIAM reca una decalcomania indelebile, cotta ad altissima temperatura, nella quale viene riportato oltre al marchio aziendale, un codice che permette di ricostruire il suo intero ciclo produttivo.

FIAM est une entreprise certifiée UNI EN ISO 9001; la conformité à cette norme de référence permet à FIAM d'atteindre des niveaux de qualité très élevés. La traçabilité des produits en est une preuve: chaque produit FIAM porte une décalcomanie indélébile, cuite à très haute température, qui mentionne la marque de l'entreprise et un code permettant de reconstruire tout son cycle de production.

Fiam is certified UNI EN ISO 9001; the conformity to this reference norm allows Fiam to reach the highest quality standards. One of the direct evidences is the possibility to track of the products: a high temperature and therefore indelible decal is applied to every article, in addition to the company logo, this decal also bears a number of codes that allow the production cycle details of the article to be traced.

FIAM ist nach UNI EN ISO 9001 zertifiziert und garantiert damit für höchste Qualitätsstandards. Dazu gehört auch die Nachverfolgbarkeit des Entstehungsweges der Erzeugnisse: Jedes FIAM-Produkt wird mit einem bei hohen Temperaturen eingebrannten Abziehbild versehen, auf dem neben dem Markenzeichen des Herstellers eine Identifikationsnummer steht, anhand der sich der gesamte Produktionszyklus des Artikels nachverfolgen lässt.

AZIENDA CON SISTEMA DI GESTIONE
PER LA QUALITÀ CERTIFICATO DA ICILA
UNI EN ISO 9001:2008

Fiam, garanzia di qualità

Fiam, guarantee of quality



art direction
adele martelli

photo art direction
adele martelli
acanto comunicazione
(carlo piazzesi)

rendering images
acanto comunicazione

photography and postproduction
studio amatibacciardi
studio leon

styling
monti studio
candida zanelli and serenella parri
conti | marchetti studio

marketing project
daniele livi

coordination and logistics
lorenzo marzoli

selections
olimpia visual plan

print and packaging
gruppo leardini

february 2023

Fiam Italia
Via Ancona 1/b
61010 Tavullia (PU)
Italy

T: +39 0721 20051
F: +39 0721 202432

fiamitalia.it
info@fiamitalia.it

#fiamitalia

follow us on



credits

ALESSI
ALFRED DRAGO RENS - GALLERIA L'AFFICHE
AMINI CARPET
ANTONINO SCIORTINO
APPLE
ARFLEX
ARTEK
ATELIER POLYHEDRE
AXIL
AYTM
BAXTER
BOFFI
BONACINA 1889
BPA INTERNATIONAL
BUSNELLI di Gruppo Industriale Busnelli
CAPPELLINI
CARPET EDITION
CECILIA MARINO
CERAMICHE ARTISTICHE BOTTEGA VIGNOLI
CINOVA di Gruppo Industriale Busnelli
COHEN SEDGH TAPPETI
COOEE DESIGN
CORAXART
D3CO
DAVIDE LOVATTI
DEDAR
DE PADOVA
DESALTO
EDD
EDIZIONIDESIGN
ENTRATA LIBERA
FELIS
FFERRONE DESIGN
FIAMMETTA MARMI
FIANDRE ARCHITECTURAL SURFACES / IRIS CERAMICA
FINN FORM PER ITTALA
FLOS
FLOU
FONTANAARTE
FOSCARINI
GALLERIA ARTRA MILANO
GOLRAN
HK LIVING
IL FANALE GROUP
IL LOFT
INCIPIPLAB
JAB
KASTHALL
LES OTTOMANS
LISTONE GIORDANO
LIVING DIVANI
LUCEPLAN
MANI BY BRITTA HERRMANN
MARINO CRISTAL
MARTA FULVI
MARTINELLI LUCE
MATI
MATTIAZZI
MM LAMPADARI
MODO LUCE
MOROSO
MY HOME COLLECTION
NAHOOR
NANIMARQUINA
OLUCE
OPIFICIO SERICO FIORENTINO
ORIZZONTI
PANZERI ILLUMINAZIONE
PIANCA E OTTOEMEZZO
POLIFORM
RAW
RATTI BOUTIQUE
REZINA
RINA MENARDI
ROMAGNOLI ARREDAMENTI PESARO
ROSENTHAL
SALVIATI
SAMBONET
SANTA & COLE
SCANDOLA MARMI
SERVOMUTO
SFORZIN ILLUMINAZIONE
SILVA TESSUTI
TATO ITALIA
TOOY
VIBIEFFE 85
VERY WOOD
VITRA
ZAFFERANO
ZENO FINOTTI SCULTURE



LEO
NAR
DO

Premio Leonardo
Qualità Italia 2015

