

# .édition

Alabaster Lighting



ATELIER ALAIN ELLOUZ  
PARIS



Acquiring one of Atelier  
Alain Ellouz' pieces gives  
access to one of earth's  
mysteries.

Alain Ellouz

## .édition

WITH ITS CLEAN STYLE,  
THE COLLECTION OF UNIQUE  
AND EASY-TO-INSTALL  
ALABASTER LIGHTING  
ELEMENTS REFLECTS THE  
SPIRIT OF THE ATELIER ALAIN  
ELLOUZ BRAND

Alabaster is central to the designs from Atelier Alain Ellouz, where artisans sculpt the stone to reveal its vibrant richness.

Atelier Alain Ellouz never loses sight of its standards of excellence and its quest for sleek design. The workshop combines these objectives with a unique know-how to unveil the hidden treasures of alabaster by creating exceptionally bold pieces, often valued as works of art.

With the **.édition** collection, Atelier Alain Ellouz seeks to open its refined, imaginative design to a wider audience.

This collection includes table lamps, pendant lights and wall lighting that offer quintessential Atelier Alain Ellouz style.

Our alabaster luminaires are designed with elegant forms and supported by sleek structures in an expression of shape and light. The precise and controlled lighting system brings alabaster to life in contrasts of light and shadow to create a remarkably magnetic appeal.



## ECO-DESIGN

In keeping with the ethics of eco-design, this collection makes use of the smallest alabaster stones extracted at the same time as the larger blocks. Nothing is lost, we recover every piece... Atelier Alain Ellouz takes this once squandered treasure from the earth and transforms it into a work of art.

## FAMILIES

**.édition** embraces the new concept of families, a collection of different types and formats of lighting elements all based on a similar style. Their common material and design confer coherence and unity to a project.

**.édition** 4/5  
ATELIER ALAIN ELLOUZ 242/251

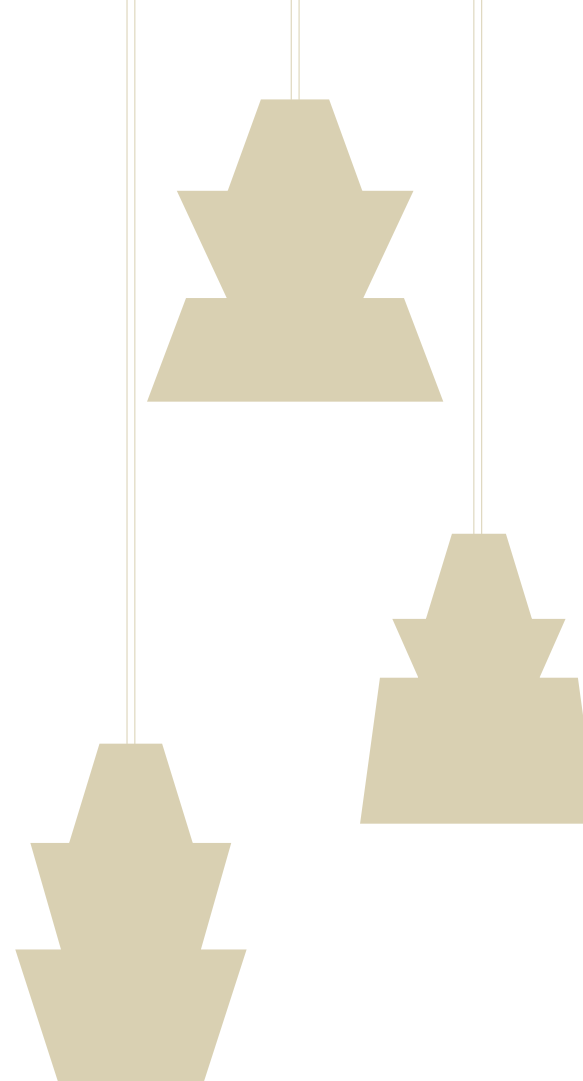

## PENDANT LIGHT 8

ALIX	10
ALIX 24	20
EMMA	92
OKI	106
PRAGUE	68
TEN-MA-DO	58
YAK	116
YOKO	128
YUM	136
ZELIE	100
ICONIC LAB S18	44
ICONIC LAB S51	24
ICONIC FLO S	30
ICONIC PLI S	36
DIVINES CAMILLE	78
DIVINES CELINE	82
DIVINES COLETTE	86

## WALL LIGHT 144

ICONIC FLO A	146
ICONIC LAB A	152
ICONIC PLI A	158

## TABLE LAMP 166

ICONIC GAMA L26	168
ICONIC GAMA L36	174

## NOMADIC LAMP 180

ATHENA	182
ICONIC GAMA	194
ICONIC LYRA	206
MONA	218

## FAMILIES 232

DIVINES	234
ICONIC	238

# PENDANT LIGHTS

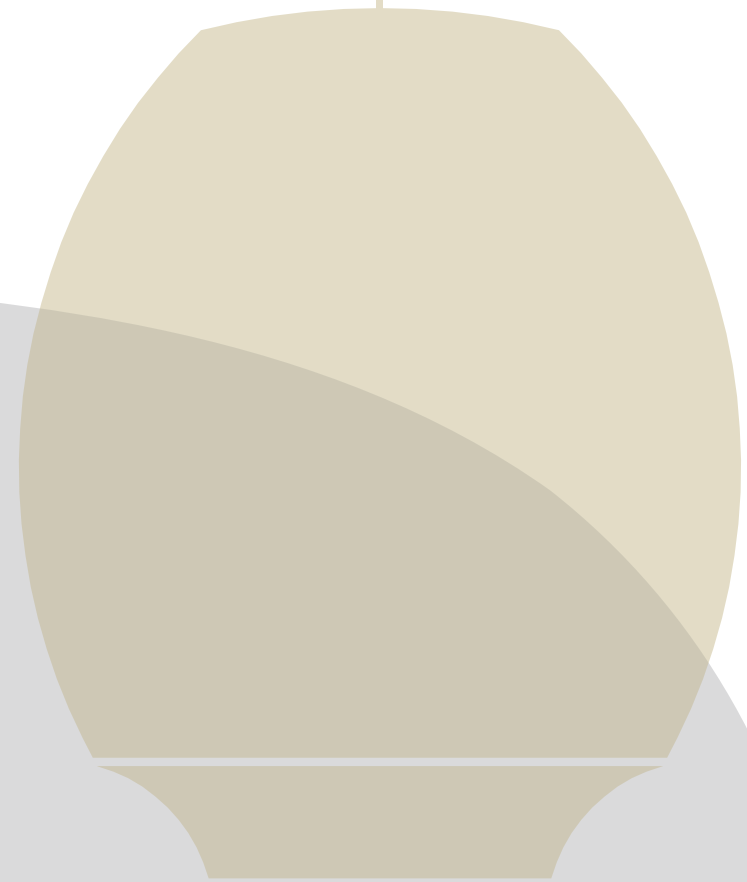
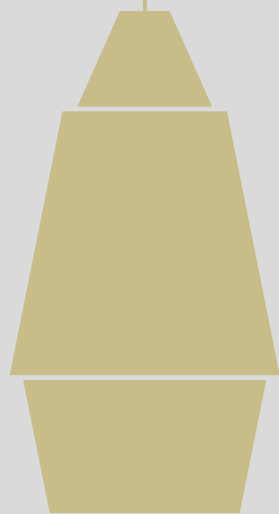
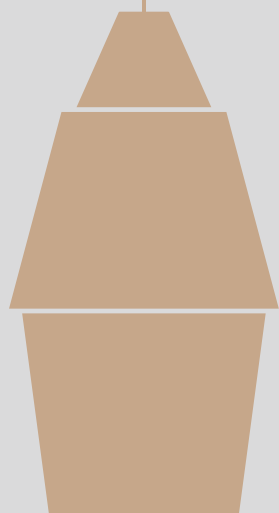
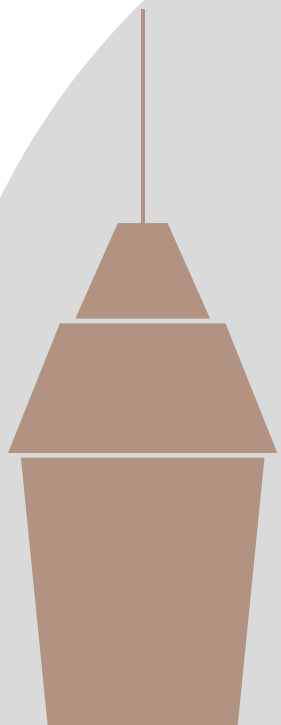

**.édition** pendant lights are elegant, contemporary, and defy the laws of gravity. Small or large, installed alone or in a composition, these pieces give the alabaster stone a weightlessness thanks to their well-balanced and harmonious floating shapes. **.édition** pendant lights are inspired by Japanese art and organic forms. They share simple alabaster design and subtle geometrical contours. As direct light or as a more diffused radiance, they adapt to any room thanks to their easy installation.

# ALIX

.édition



Resolute, ALIX amplifies the stone's qualities. Clean, geometrical lines contrast alabaster's irregular, delicate patterns. ALIX' soft radiance sets the mood, while its narrow rim concentrates the diffused light. Hang ALIX pendant lights at staggered heights for a graphic composition in your living room or library, for example.

ALIX

édition

PENDANT LIGHT





ALIX  
édition

PENDANT LIGHT



ALIX  
.édition

PENDANT LIGHT





# ALIX

.édition

## PENDANT LIGHT

<b>REFERENCE</b>	ALIX 14 : ED-0049 ALIX 17 : ED-0017
<b>UL LISTED REFERENCE</b>	ALIX 14 : ED-0050 ALIX 17 : ED-0018
<b>ENVIRONNEMENT</b>	Indoor
<b>MATERIALS</b>	Alabaster
<b>SUSPENSION</b>	Black canopy with black textile cable
<b>DIMENSIONS</b>	

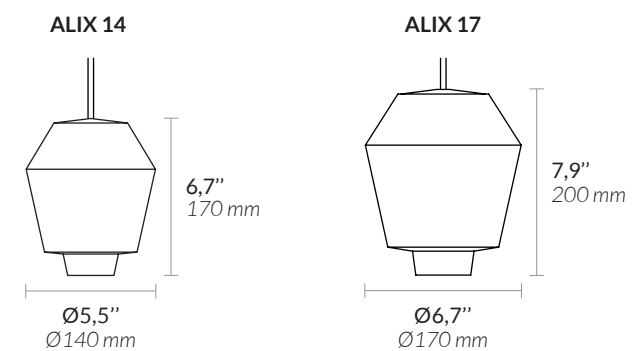

<b>WEIGHT</b>	ALIX 14 : 5,5 lbs / 2,5 kg ALIX 17 : 6,6 lbs / 3 kg
---------------	--

# ALIX 24 .édition

PENDANT LIGHT



ALIX 24 has the same sleek lines as its little sisters ALIX 14 and 17. The size variation gives it a more assertive presence. Its suspension system hung by a transparent rope and cable is unique. The three sizes of ALIX can be combined together to form a dynamic composition. In this case, ALIX 14 and 17 will be fixed in height on a rope to respect the harmony of the set.



# ALIX 24

.édition

## SUSPENSION

<b>REFERENCE</b>	ED-0029
<b>UL LISTED REFERENCE</b>	ED-0056
<b>ENVIRONNEMENT</b>	Indoor
<b>MATERIALS</b>	Alabaster
<b>SUSPENSION</b>	Mat white canopy Stainless steel wire rope with transparent electric cable

## DIMENSIONS

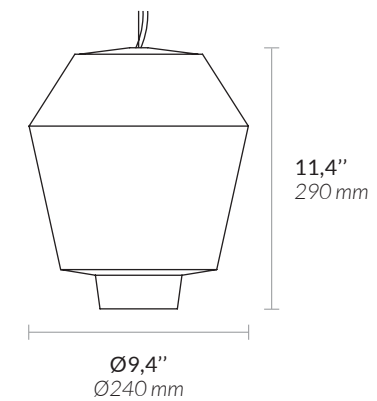

<b>WEIGHT</b>	8,8 lb / 4 kg
---------------	---------------

LAB S51  
.édition



Monolithic, carved from a single stone, our Iconic LAB monumental pendant light imposes the power of its presence above a dining table. The wide opening at its base diffuses a generous light.

LAB Concept

With its three cones of various volumes, Iconic LAB offers a graphic geometry. A harmonious alabaster composition with perfect proportions. LAB is also available as a small pendant light and as a wall light.

LAB S51  
.édition

PENDANT LIGHT

ICONIC





# LAB S51

.édition

PENDANT LIGHT

<b>REFERENCE</b>	ED-0070
<b>UL LISTED REFERENCE</b>	ED-0071
<b>ENVIRONNEMENT</b>	Indoor
<b>MATERIALS</b>	Alabaster
<b>SUSPENSION</b>	Black canopy, transparent electric cable with 3 suspension stainless steel wire rope

**DIMENSIONS**

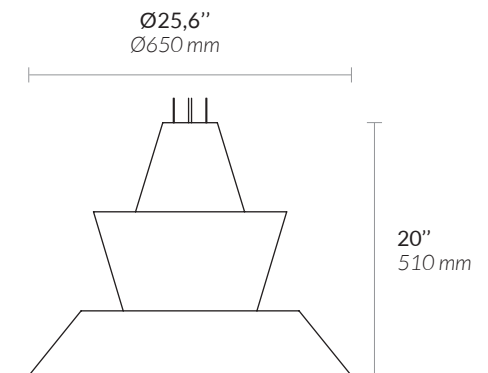

<b>WEIGHT</b>	83,8 lb / 38 kg
---------------	-----------------

# FLO S

.édition

Our Iconic FLO pendant lights combine direct lighting and diffused luminosity. They can be mixed with LAB and PLI suspensions to form a dynamic trio.

## FLO concept

Iconic FLO embodies the return to the primary function of lighting: glowing in the dark. A sort of modernist torch with an essential and minimalist design. Iconic FLO reveals the mysteries and vibrations of the stone in homage to alabaster. FLO is also available as a wall light.



FLOS

.édition

PENDANT LIGHT





# FLO S

.édition

PENDANT LIGHT

<b>REFERENCE</b>	ED-0066
<b>UL LISTED REFERENCE</b>	ED-0067
<b>ENVIRONNEMENT</b>	Indoor
<b>MATERIALS</b>	Alabaster
<b>SUSPENSION</b>	Black canopy and black textile cable
<b>DIMENSIONS</b>	

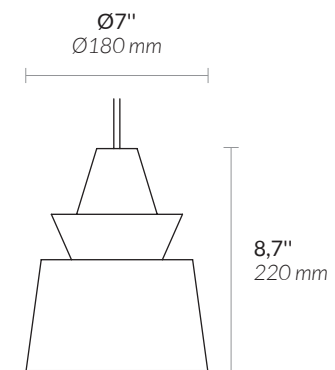

<b>WEIGHT</b>	6,6 lb / 3 kg
---------------	---------------

# PLI S

.édition

Alone or as a composition, our Iconic PLI graphic pendant light suits any table. Associated with LAB and FLO of the same family, the three pendant lights form a dynamic trio.

## PLI concept

PLI is the most ludic model in the Iconic family. Made up of three conical trunks of different sizes, Iconic PLI seems to be retractable like pop-up cards. PLI is also available as a wall light.



PLIS

.édition

PENDANT LIGHT



PLIS  
.édition

PLIA  
.édition

PLIS  
.édition





# PLI S

.édition

## PENDANT LIGHT

<b>REFERENCE</b>	ED-0072
<b>UL LISTED REFERENCE</b>	ED-0073
<b>ENVIRONNEMENT</b>	Indoor
<b>MATERIALS</b>	Alabaster
<b>SUSPENSION</b>	Black canopy and black textile cable
<b>DIMENSIONS</b>	

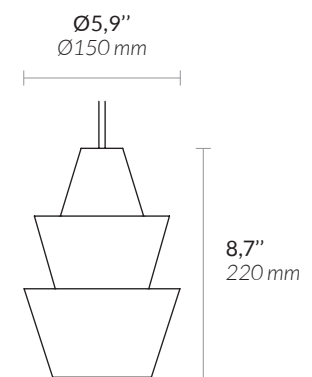

<b>WEIGHT</b>	6,6 lb / 3 kg
---------------	---------------

LAB S18  
 .édition



Alone or as a composition, our small Iconic LAB suspensions punctuate the decoration of your interiors. Associated with FLO and PLI of the same family, the three pendant lights form a dynamic trio.

LAB Concept

With its three cones of various volumes, Iconic LAB offers a graphic geometry. A harmonious alabaster composition with perfect proportions. LAB is also available as a monumental pendant light and as a wall lamp.

LAB S18  
.édition

PENDANT LIGHT

ICONIC







LAB S18  
édition

PENDANT LIGHT





# LAB S18

.édition

**PENDANT LIGHT**

<b>REFERENCE</b>	ED-0068
<b>UL LISTED REFERENCE</b>	ED-0069
<b>ENVIRONNEMENT</b>	Indoor
<b>MATERIALS</b>	Alabaster
<b>SUSPENSION</b>	Black canopy and black textile cable
<b>DIMENSIONS</b>	

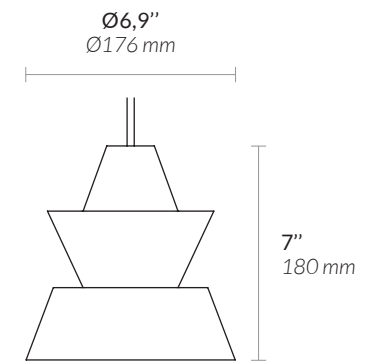

<b>WEIGHT</b>	5,5 lb / 2,5 kg
---------------	-----------------

FLO s

PLI s

LAB s18





# TEN-MA-DO

**.édition**

Designed as a set, the TEN, MA and DO luminaires form a subtle geometric composition. Their fine lines and modern dimensions make them ideal in contemporary decor.

TEN-MA-DO

PENDANT LIGHT

édition



PENDANT LIGHT  
TEN-MA-DO  
.édition





TEN-MA-DO  
PENDANT LIGHT  
.édition





# TEN-MA-DO

.édition PENDANT LIGHT

<b>REFERENCE</b>	ED-0047
<b>UL LISTED REFERENCE</b>	ED-0048
<b>ENVIRONNEMENT</b>	Indoor
<b>MATERIALS</b>	Alabaster
<b>SUSPENSION</b>	Black canopy with black textile cable.
<b>DIMENSIONS</b>	

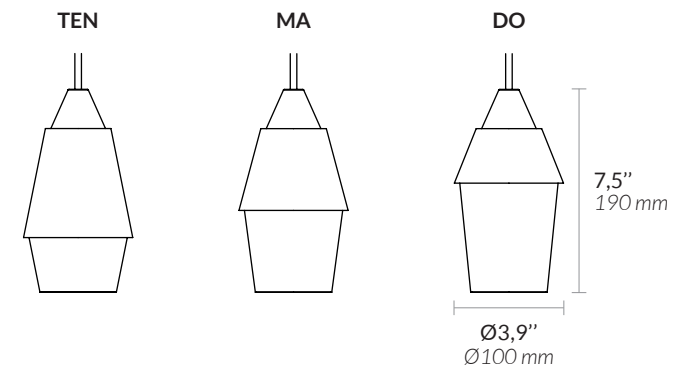

<b>WEIGHT</b>	TEN : 1 kg MA : 1 kg DO : 1 kg
---------------	--------------------------------------

# PRAGUE

.édition



As a sculpture in harmony with nature, PRAGUE is like a stone teardrop. Its weightless design softens the stone's character. Hang them in a cluster of different sizes to add charm and fullness to your interior. With its soft radiance, PRAGUE exudes tranquility in your bedroom.

# PRAGUE

.édition

PENDANT LIGHT



PRAGUE  
.édition

PENDANT LIGHT



# PRAGUE

.édition

PENDANT LIGHT

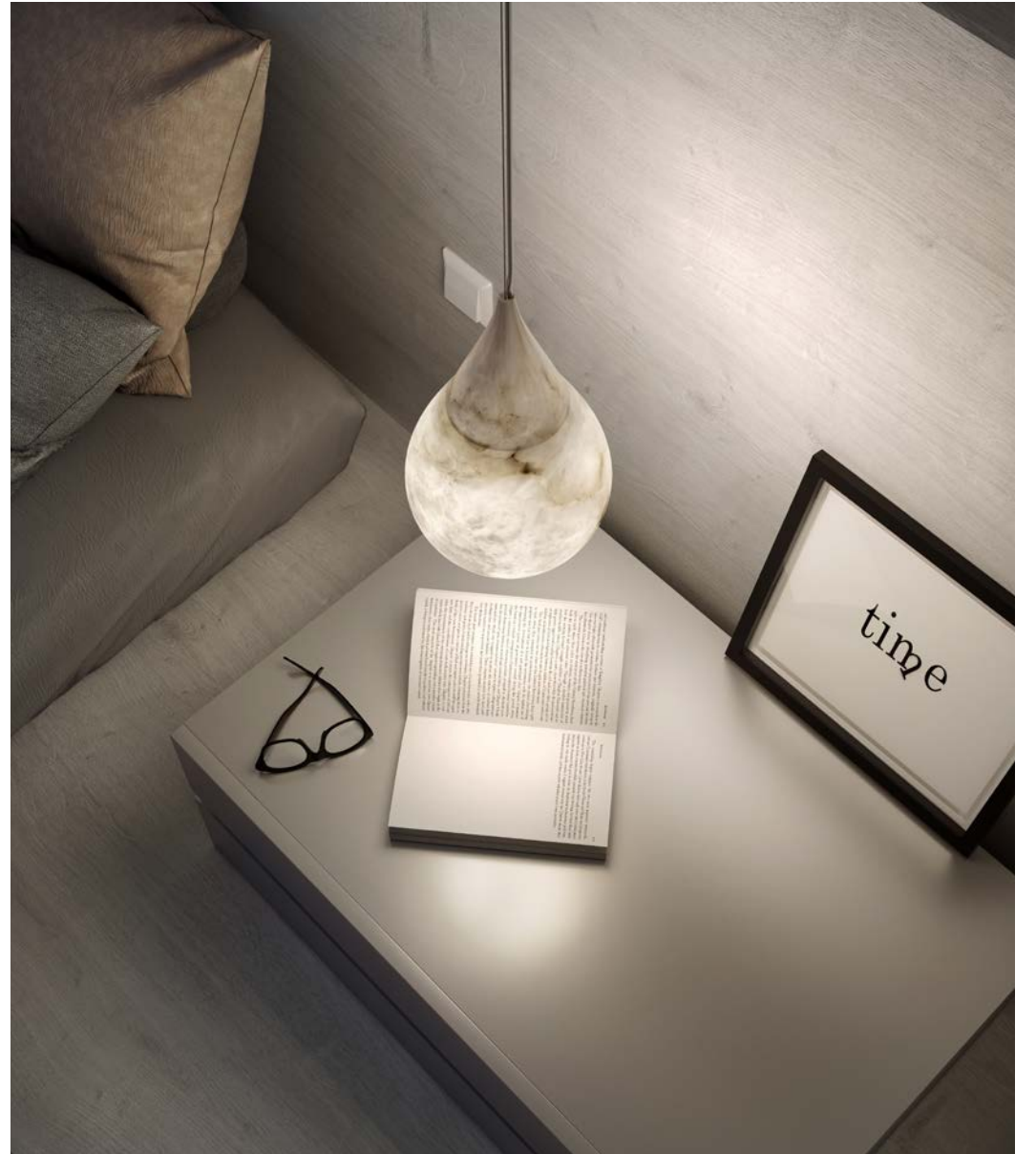
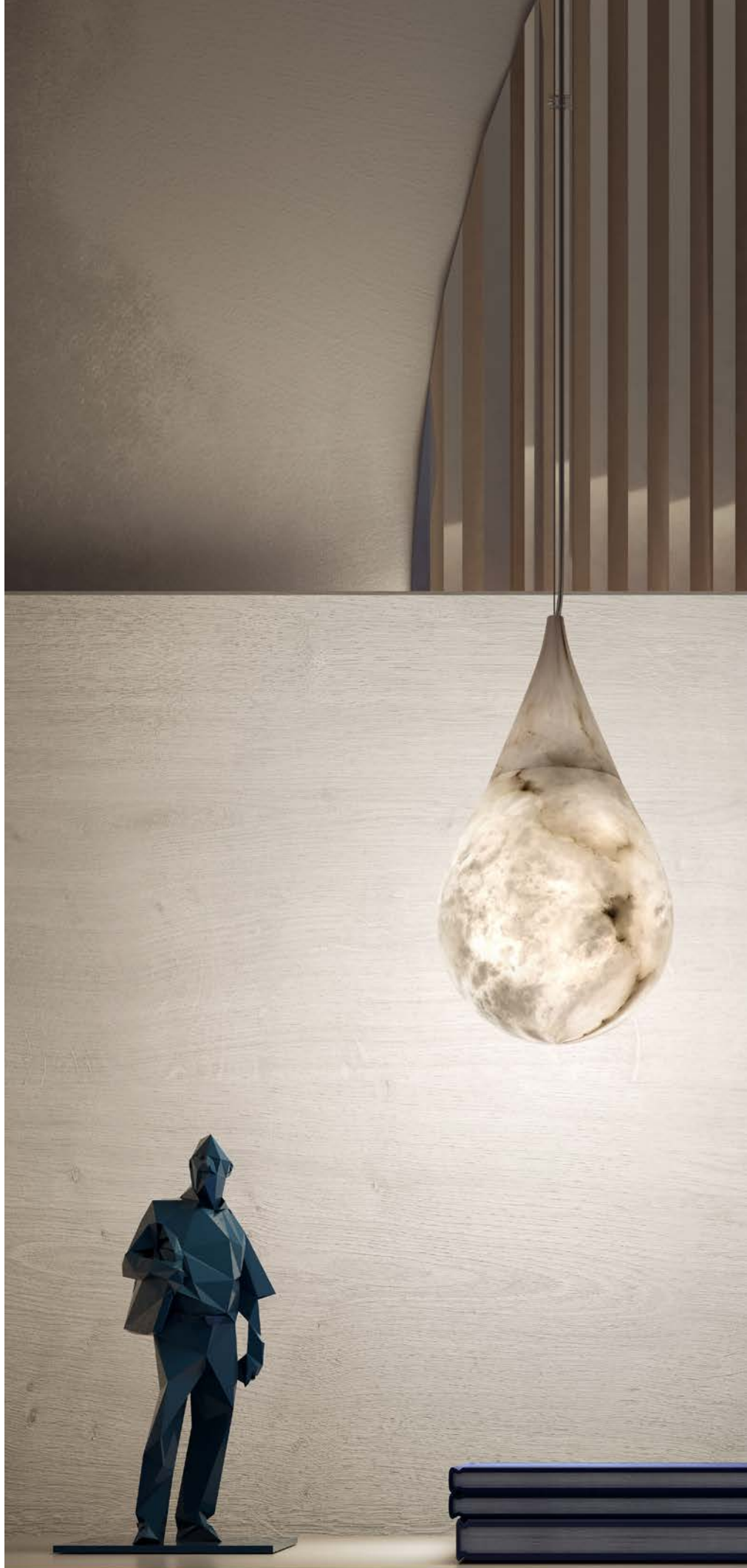



# PRAGUE

.édition

PENDANT LIGHT

**REFERENCE**

PRAGUE 20 : ED-0029  
 PRAGUE 30 : ED-0031  
 PRAGUE 45 : ED-0033

**UL LISTED REFERENCE**

PRAGUE 20 : ED-0030  
 PRAGUE 30 : ED-0032  
 PRAGUE 45 : ED-0034

**ENVIRONNEMENT**

Indoor

**MATERIALS**

Alabaster

**SUSPENSION**

White mat canopy  
 Stainless steel wire rope + transparent electric cable

**DIMENSIONS**

**PRAGUE 20**

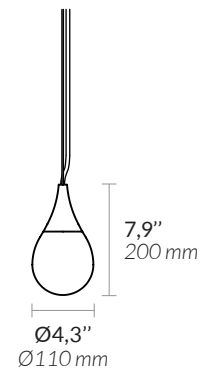

**PRAGUE 30**

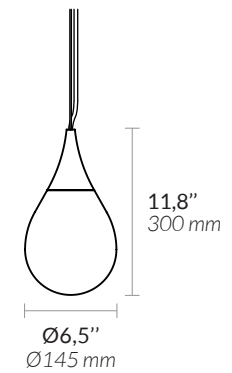

**PRAGUE 45**

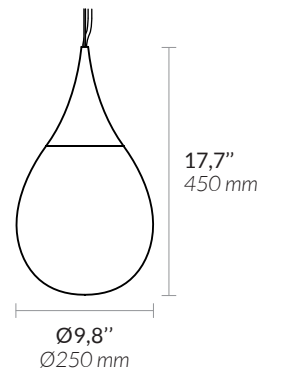

**WEIGHT**

PRAGUE 20 : 2,2 lbs / 1 kg  
 PRAGUE 30 : 5,5 lb / 2,5 kg  
 PRAGUE 45 : 12,1 lb / 5,5 kg



# CAMILLE

**.édition**

CAMILLE floats above you like a Chinese lantern in a poetic and weightless expression. Charming curves coax a balance between its internal light and direct radiance. CAMILLE is resolutely elegant with its sleek, alabaster design. Compose your lighting with CAMILLE, CELINE, and COLETTE, three elegant and contemporary pieces to embellish any dining room.





# CAMILLE

.édition

PENDANT LIGHT

<b>REFERENCE</b>	ED-0021
<b>UL LISTED REFERENCE</b>	ED-0022
<b>ENVIRONNEMENT</b>	Indoor
<b>MATERIALS</b>	Alabaster
<b>SUSPENSION</b>	White mat canopy Stainless steel wire rope + transparent electric cable

**DIMENSIONS**

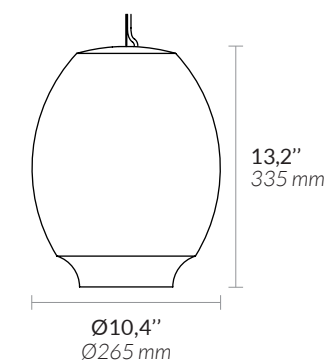

<b>WEIGHT</b>	15,9 lb / 7,2 kg
---------------	------------------

# CELINE

.édition

Hanging generously above you, CELINE is the ideal pendant light for a dining room table. Its large dome expands at the base, evoking well-balanced, feminine curves. CELINE offers controlled, soft light to create ambiance for an intimate diner. Compose your lighting with CAMILLE, CELINE, and COLETTE, three elegant and contemporary pieces to embellish any dining room.





# CELINE

.édition

PENDANT LIGHT

<b>REFERENCE</b>	ED-0025
<b>UL LISTED REFERENCE</b>	ED-0026
<b>ENVIRONNEMENT</b>	Indoor
<b>MATERIALS</b>	Alabaster
<b>SUSPENSION</b>	White mat canopy Stainless steel wire rope + transparent electric cable

**DIMENSIONS**

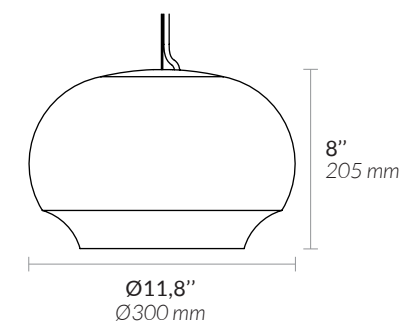

<b>WEIGHT</b>	15,9 lb / 7,2 kg
---------------	------------------

COLETTE



CELINE



CAMILLE



# COLETTE

**.édition**

As if delicately suspended in space, COLETTE'S curves form a perfect oval. Its base opens into a discreet cylinder that transforms this luminaire into a gentle pool of light. Simple. Subtle. Timeless. COLETTE amplifies alabaster's spirals, clouds and swirls. Compose your lighting with CAMILLE, CELINE, and COLETTE, three elegant and contemporary pieces to embellish any dining room.



# COLETTE

.édition

PENDANT LIGHT

<b>REFERENCE</b>	ED-0023
<b>UL LISTED REFERENCE</b>	ED-0024
<b>ENVIRONNEMENT</b>	Indoor
<b>MATERIALS</b>	Alabaster
<b>SUSPENSION</b>	White mat canopy Stainless steel wire rope + transparent electric cable

**DIMENSIONS**

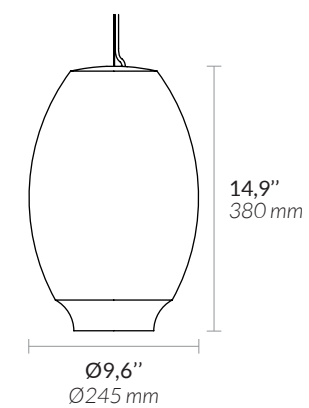

<b>WEIGHT</b>	16,5 lb / 7,5 kg
---------------	------------------



PENDANT LIGHT

CAMILLE

CELINE

COLETTE

# EMMA

.édition

The rounded contours of this generous, open design appear weightless in the space around it. Its clever, sleek symmetry gently diffuses light. EMMA is the ultimate decorative object. Hang it in a bedroom or living room to enhance your decor.



EMMA  
.édition

PENDANT LIGHT









# EMMA

.édition

## PENDANT LIGHT

<b>REFERENCE</b>	ED-0019
<b>UL LISTED REFERENCE</b>	ED-0020
<b>ENVIRONNEMENT</b>	Indoor
<b>MATERIALS</b>	Alabaster
<b>SUSPENSION</b>	White mat canopy Stainless steel wire rope + transparent electric cable

### DIMENSIONS

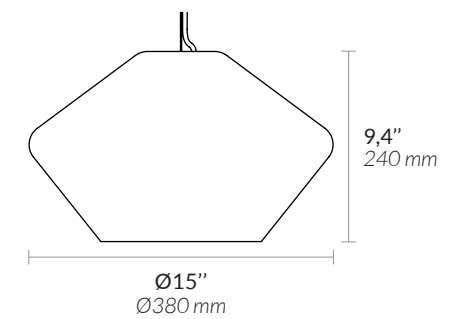

<b>WEIGHT</b>	15,9 lb / 7,2 kg
---------------	------------------

# ZELIE

.édition

ZELIE offers sober, organic lines which bring out alabaster's essential beauty. Its upper shape has the form of a traditional lampshade, gradually widening at the middle to create a short, cylindrical design. Timeless, ZELIE can embellish contemporary dining rooms or classic-style living rooms.

ZELIE  
.édition

PENDANT LIGHT





# ZELIE

.édition

## PENDANT LIGHT

<b>REFERENCE</b>	ED-0027
<b>UL LISTED REFERENCE</b>	ED-0028
<b>ENVIRONNEMENT</b>	Indoor
<b>MATERIALS</b>	Alabaster
<b>SUSPENSION</b>	White mat canopy Stainless steel wire rope + transparent electric cable

### DIMENSIONS

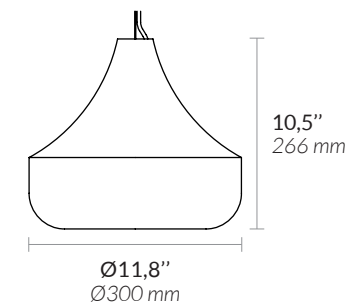

<b>WEIGHT</b>	15,9 lb / 7,2 kg
---------------	------------------

# OKI

.édition



Inspired from Japanese art, the OKI pendant light draws strength from its simplicity. Its shape is reminiscent of an ancient bowl. Sober. Smart. Essential. This light can stand alone or in a composition. Hang it above a nightstand, where it promises gentle thoughts and an escape to a faraway Mount Fuji summit.

OKI  
.édition

PENDANT LIGHT



OKI  
.édition

PENDANT LIGHT





OKI  
.édition

PENDANT LIGHT





# OKI

.édition

PENDANT LIGHT

**REFERENCE**  
OKI 14 : ED-0039  
OKI 18 : ED-0041

**UL LISTED REFERENCE**  
OKI 14 : ED-0040  
OKI 18 : ED-0042

**ENVIRONNEMENT**  
Indoor

**MATERIALS**  
Alabaster and black painted steel

**SUSPENSION**  
Black canopy with black textile cable

**DIMENSIONS**

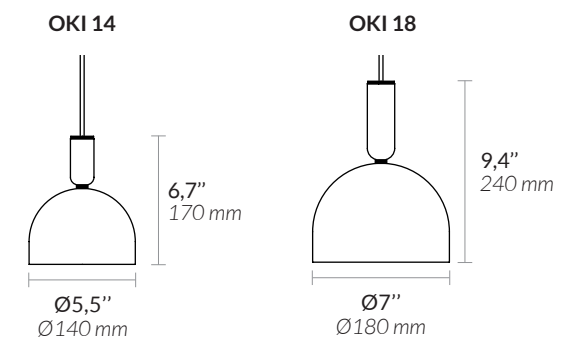

**WEIGHT**  
OKI 14 : 2,2 lb / 1 kg  
OKI 18 : 3,3 lb / 1,5 kg



# YAK

.édition

Inspired by Eastern influences, the shiny metallic top piece highlights the finesse of the alabaster sphere. Its design offers unique decor for your interior. The alabaster and brass in this YAK piece are resolutely elegant, making it the perfect addition to Art Deco interiors.



# YAK

.édition

PENDANT LIGHT



YAK  
.édition

PENDANT LIGHT



YAK  
.édition

PENDANT LIGHT



YAK  
.édition

PENDANT LIGHT



# YAK

.édition

## PENDANT LIGHT

### REFERENCE

YAK 20 : ED-0051  
YAK 25 : ED-0053

### UL LISTED REFERENCE

YAK 20 : ED-0052  
YAK 25 : ED-0054

### ENVIRONNEMENT

Indoor

### MATERIALS

Alabaster and polished brass

### SUSPENSION

Black canopy with black textile cable

### DIMENSIONS

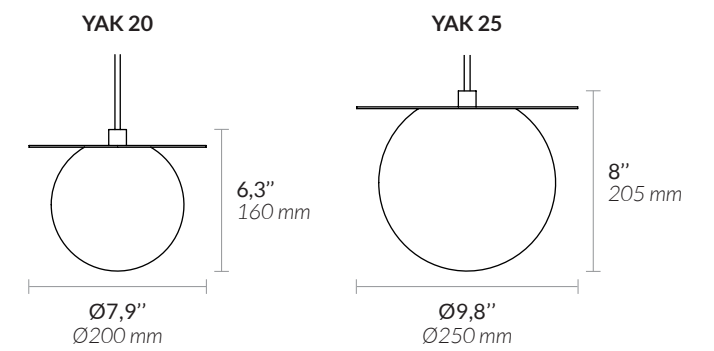

### WEIGHT

YAK 20 : 4,4 lb / 2 kg  
YAK 25 : 6,6 lb / 3 kg



# YOKO

.édition

Similar to OKI, YOKO is inspired by Japanese art. It gathers forces from the earth and heavens. The subtle alliance of the dome and sphere evokes the potter's skill, and underlines its soft, poetic light. Compose a few of them at different heights to create a contemporary, cozy ambiance.



YOKO  
.édition

PENDANT LIGHT







# YOKO

.édition

## PENDANT LIGHT

**REFERENCE** YOKO 14 : ED-0035  
YOKO 18 : ED-0037

**UL LISTED REFERENCE** YOKO 14 : ED-0036  
YOKO 18 : ED-0038

**ENVIRONNEMENT** Indoor

**MATERIALS** Alabaster

**SUSPENSION** Black canopy with black textile cable

### DIMENSIONS

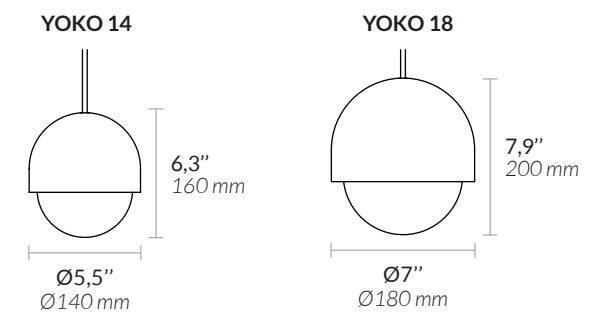

**WEIGHT** YOKO 14 : 2,2 lb / 1 kg  
YOKO 18 : 3,3 lb / 1,5 kg

# YUM

.édition

Symmetry is harmony. YUM expresses half a suspended light in the shadow of the other. Its sleek style underlines its beauty and makes it one of the centerpieces in the collection. YUM adapts especially well to 'Artsy' or minimalist interiors.



YUM  
.édition

PENDANT LIGHT



YUM

.édition

PENDANT LIGHT





# YUM

.édition

## PENDANT LIGHT

<b>REFERENCE</b>	YUM 14 : ED-0043 YUM 18 : ED-0045
<b>UL LISTED REFERENCE</b>	YUM 14 : ED-0044 YUM 18 : ED-0046
<b>ENVIRONNEMENT</b>	Indoor
<b>MATERIALS</b>	Alabaster
<b>SUSPENSION</b>	Black canopy with black textile cable

### DIMENSIONS

#### YUM 14

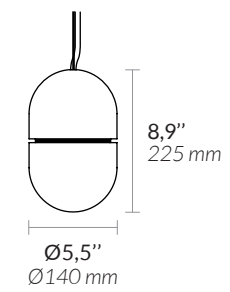

#### YUM 18

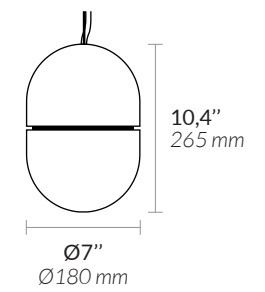

<b>WEIGHT</b>	YUM 14 : 6,2 lb / 2,8 kg YUM 18 : 9,7 lb / 4,4 kg
---------------	--



# WALL LIGHTS

Our alabaster wall lights give a timeless style to your interiors. They elegantly adorn an entrance, a hallway or a headboard. As sober as minimalist, they reveal the deep patterns of the stone while spreading a soothing and soft luminosity.

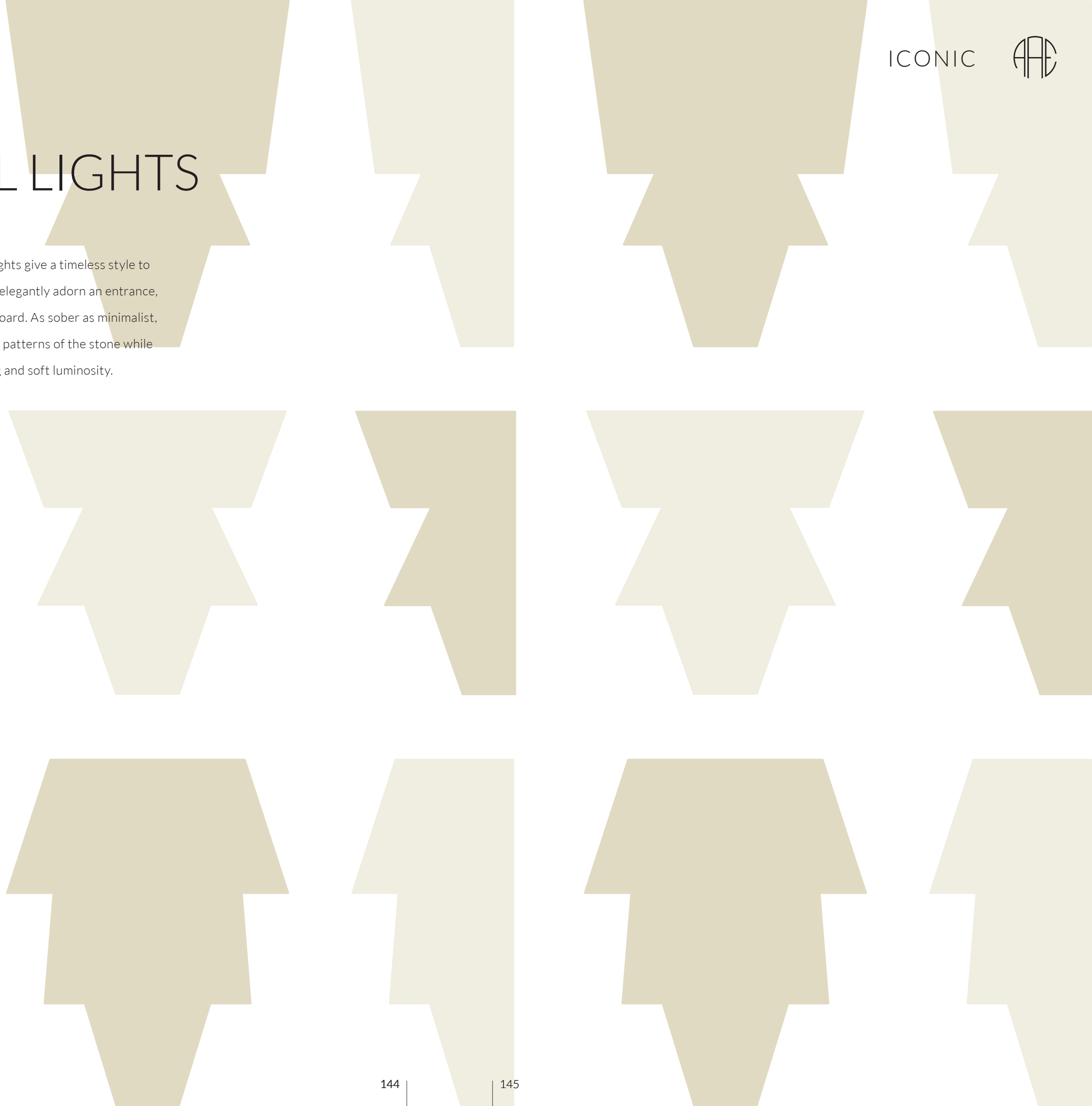

# FLO A

.édition

Our FLO wall light allows you to modulate the lighting of your hallways, bedrooms or living room while creating a special subdued atmosphere. When Iconic FLO, LAB and PLI are combined, the three wall lights form a daring composition that gives rhythm to your decoration.

## FLO concept

Iconic FLO embodies the return to the primary function of lighting: glowing in the dark. A sort of modernist torch with an essential and minimalist design. Iconic FLO reveals the mysteries and vibrations of the stone in homage to alabaster. FLO is also available as a pendant light.



FLO A  
.édition

WALL LIGHT





# FLO A

.édition

WALL LIGHT

<b>RÉFÉRENCE</b>	ED-0060
<b>ENVIRONNEMENT</b>	Intérieur
<b>MATÉRIAUX</b>	Albâtre
<b>DOUILLE</b>	Ampoule LED flamme E14 3W 2700K 320 lm - Variable
<b>DIMENSIONS</b>	

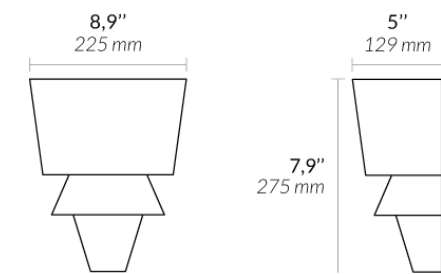

<b>POIDS</b>	3 kg
--------------	------

# LAB A

**.édition**



Our Iconic LAB wall light enhances your interiors or simply decorates your walls. When Iconic LAB, PLI and FLO are combined, the three wall lights form a daring composition that gives rhythm to your decoration.

#### LAB concept

With its three cones of various volumes, Iconic LAB offers a graphic geometry. A harmonious alabaster composition with perfect proportions. LAB is also available in small and monumental pendant lights.



LAB A  
.édition

WALL LIGHT





# LAB A

.édition

**WALL LIGHT**

<b>REFERENCE</b>	ED-0064
<b>UL LISTED REFERENCE</b>	ED-0065
<b>ENVIRONNEMENT</b>	Indoor
<b>MATERIALS</b>	Alabaster
<b>DIMENSIONS</b>	

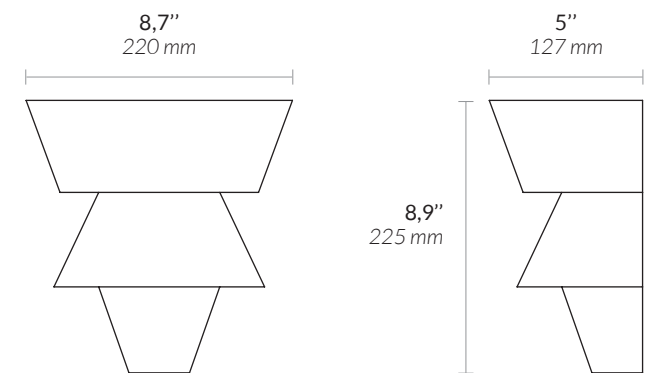

<b>WEIGHT</b>	5,5 lb / 2,5 kg
---------------	-----------------

# PLI A

**.édition**

Our Iconic PLI wall light transforms your walls and illuminates your rooms while optimizing space (for small surfaces). When Iconic PLI, LAB and FLO are combined, the three wall lights form a daring composition that gives rhythm to your decoration.

### PLI concept

PLI is the most ludic model in the Iconic family. Made up of three conical trunks of different sizes, Iconic PLI seems to be retractable like pop-up cards. PLI is also available as a pendant light.



PLI A  
édition

WALL LIGHT





PLIA

édition

WALL LIGHT

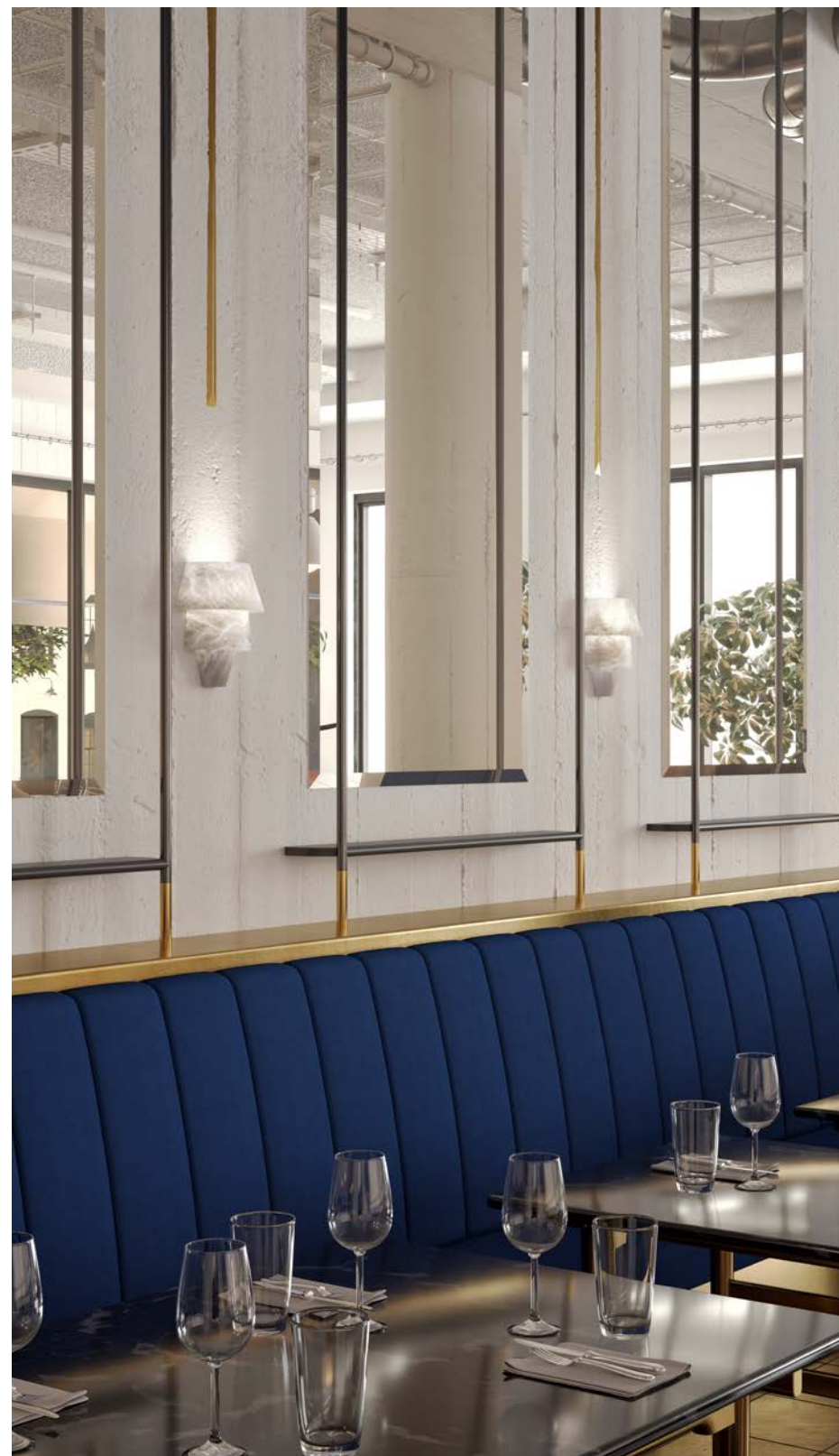



# PLI A

.édition

WALL LIGHT

<b>REFERENCE</b>	ED-0062
<b>UL LISTED REFERENCE</b>	ED-0063
<b>ENVIRONNEMENT</b>	Indoor
<b>MATERIALS</b>	Alabaster
<b>DIMENSIONS</b>	

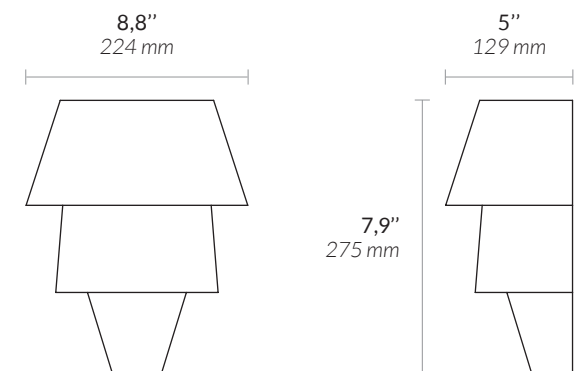

<b>WEIGHT</b>	6.6 lb / 3 kg
---------------	---------------

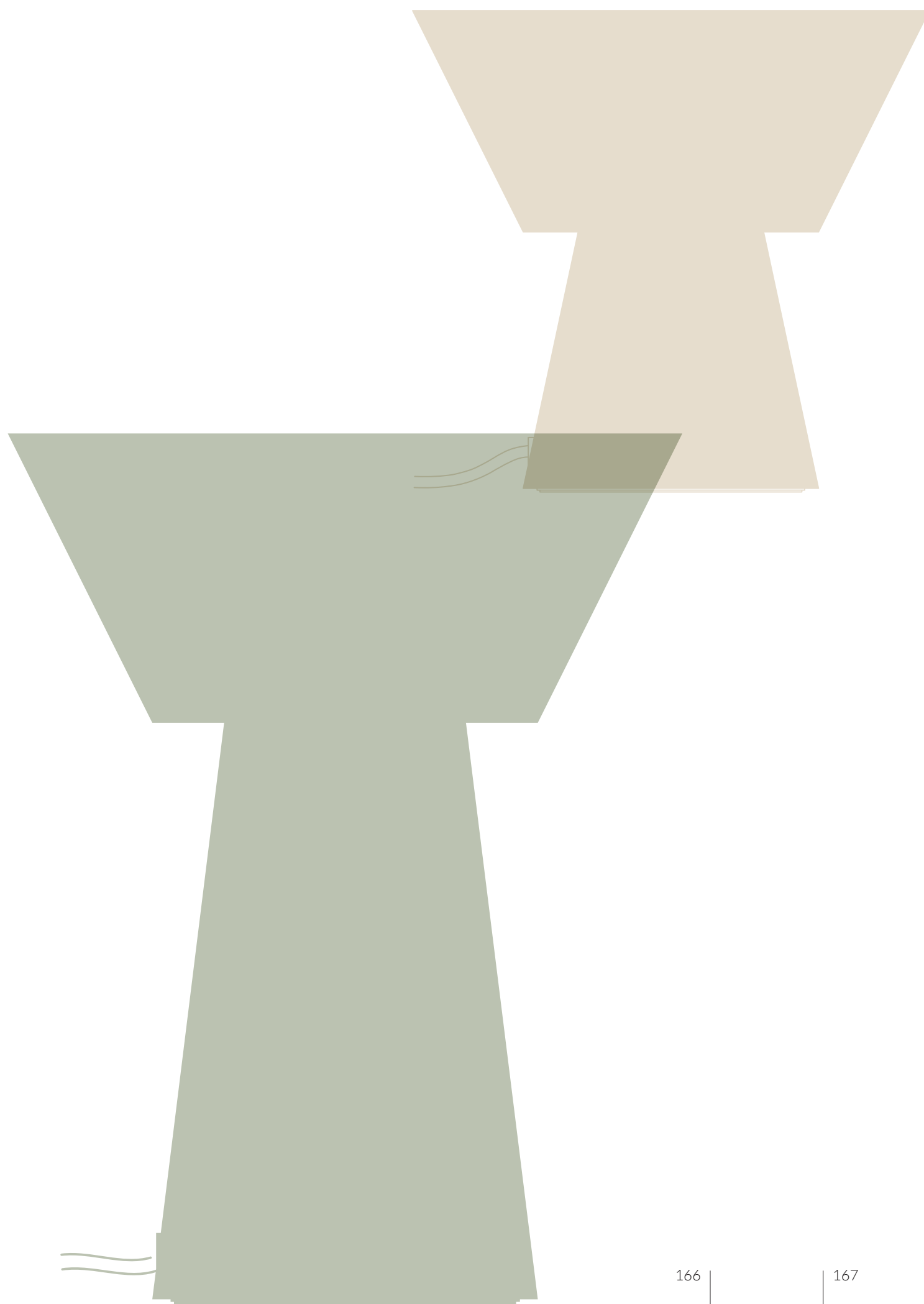

## TABLE LAMPS

Your consoles or bedside tables have found an ideal companion to highlight them in a theatrical way. The simplicity of their shape combined with the power of alabaster make them genuine collector's pieces. Alabaster stone diffuses a delicate and lively light, inviting to contemplate this creation.

ICONIC



# GAMA L26

.édition



Iconic GAMA reinterprets the table lamp in contemporary fashion, in a play of curves and sleek lines. As for a classic lamp, Iconic GAMA consists of a base and a lampshade, separated by a delicate golden brass trim. The edges are fine and precise; the perfect proportions. The illuminated upper body magnifies the essential beauty of alabaster, providing a timeless elegance to this creation. GAMA is also available in a taller version and as a nomadic lamp.



# GAMA L26

.édition

TABLE LAMP

<b>REFERENCE</b>	ED-0057
<b>UL LISTED REFERENCE</b>	ED-0059
<b>ENVIRONNEMENT</b>	Indoor
<b>MATERIALS</b>	Alabaster, polished brass and white painted steel
<b>DIMENSIONS</b>	

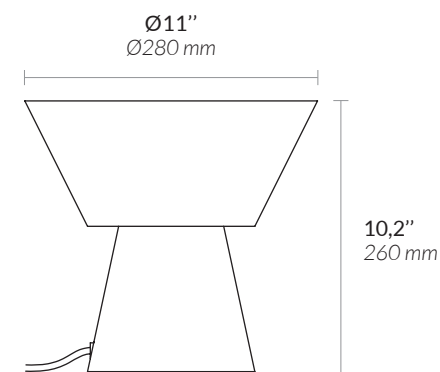

<b>WEIGHT</b>	17,6 lb / 8 kg
---------------	----------------



# GAMA L36

.édition

Iconic GAMA reinterprets the table lamp in contemporary fashion, in a play of curves and sleek lines. As for a classic lamp, Iconic GAMA consists of a base and a lampshade, separated by a delicate golden brass trim. The edges are fine and precise; the perfect proportions. The illuminated upper body magnifies the essential beauty of alabaster, providing a timeless elegance to this creation. GAMA is also available in a medium sized model and as a nomadic lamp.

Iconic GAMA réinterprète de manière contemporaine la lampe à poser, dans un jeu de courbes et de lignes épurées. Comme pour une lampe classique, Iconic GAMA se compose d'un pied et d'un abat-jour, séparés par un délicat pourtour en laiton doré. Les arêtes sont fines et précises; les proportions parfaites. Éclairée, la partie supérieure magnifie la beauté essentielle de l'albâtre et procure une élégance intemporelle à l'ensemble. GAMA existe aussi en version plus haute L36 et en lampe autonome.





GAMA L36  
édition  
TABLE LAMP



# GAMA L36

.édition

TABLE LAMP

<b>REFERENCE</b>	ED-0056
<b>UL LISTED REFERENCE</b>	ED-0058
<b>ENVIRONNEMENT</b>	Indoor
<b>MATERIALS</b>	Alabaster, polished brass and white painted steel
<b>DIMENSIONS</b>	

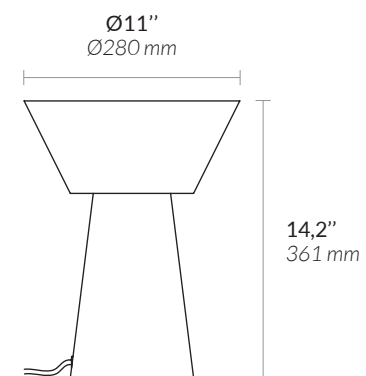

<b>WEIGHT</b>	19,8 lb / 9 kg
---------------	----------------

# NOMADIC LAMPS

Available in cylindrical, spherical, conical and ellipsoidal shapes, **.édition** nomadic lamps associate simple shapes borrowed from geometrical lines. These lamps feature an innovative technology to offer eight hours of use at a time. Light reveals alabaster's energy and enhances these hand-crafted, sleek compositions. The result is captivating! Resolutely elegant and luxuriously simple, **.édition** nomadic lamps provide presence throughout the day. Alone, or in a composition, they can create an intimate ambiance as a table centerpiece, dim the light in an office or library space or usher in the last rays of sunlight when set at the edge of a patio.

# ATHENA

.édition

A sphere delicately sits atop a cylinder in absolute harmony. ATHENA evokes the Earth's orbit around the sun. Alabaster's translucence diffuses a soothing light that reveals its characteristic patterns. Those seemingly fluid motions in the stone are reminiscent of ocean currents. ATHENA is an invitation to travel the world, a peaceful voyage from the comfort of your sofa.



# ATHENA

.édition

NOMADIC LAMP



ATHENA  
.édition

NOMADIC LAMP



# ATHENA

.édition

NOMADIC LAMP

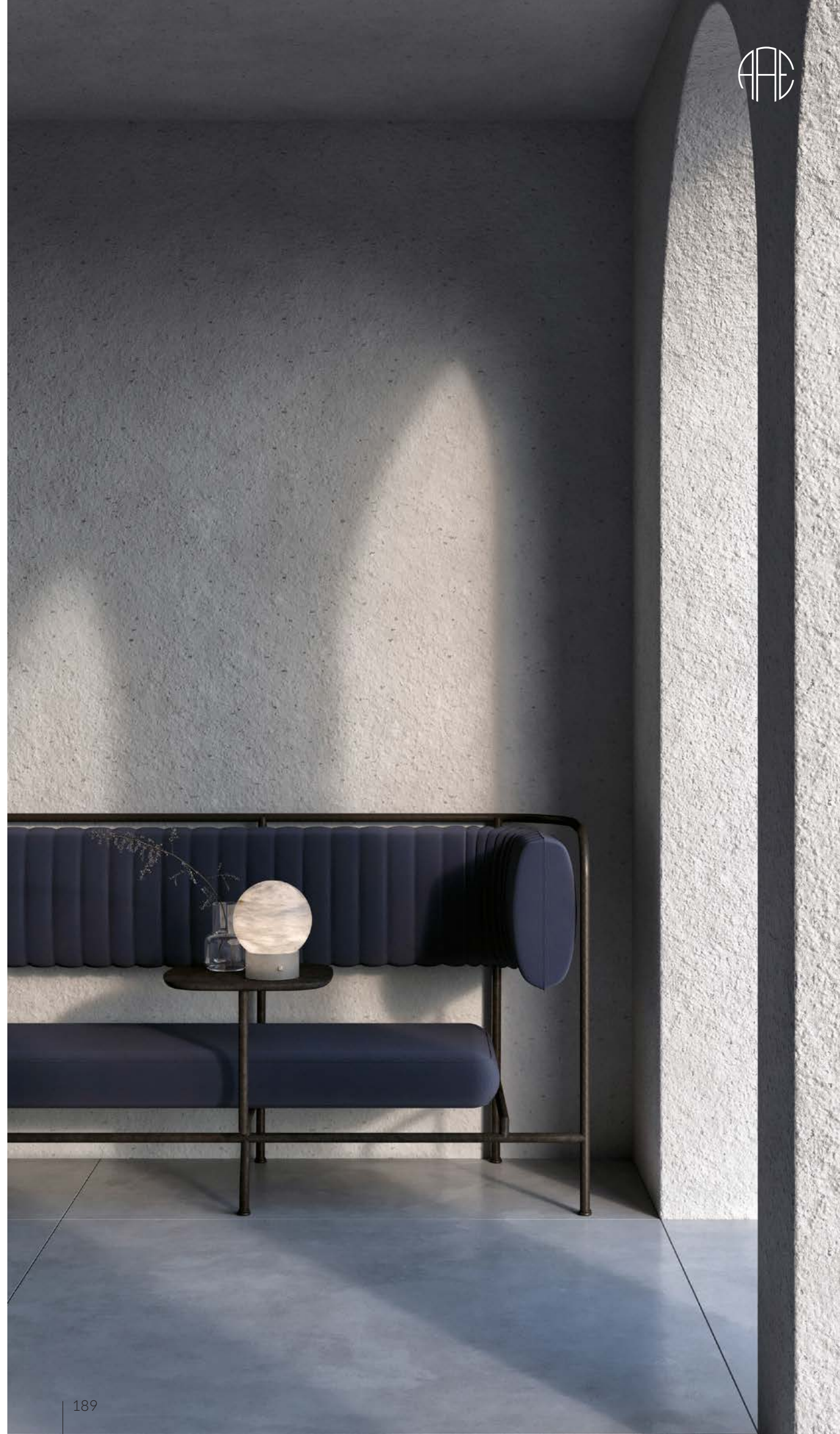

ATHENA  
.édition

NOMADIC LAMP







# ATHENA

.édition

NOMADIC LAMP

<b>REFERENCE</b>	ED-0005
<b>REFERENCE WITH UL LISTED CHARGER</b>	ED-0007
<b>ENVIRONNEMENT</b>	Indoor
<b>MATERIALS</b>	Alabaster, brass and painted steel
<b>LIGHT SOURCE</b>	Variable intensity LED Color temperature : 3000K
<b>LIGHT SWITCH</b>	Brass button integrated to the lamp : sensitive switch / dimmer.
<b>BATTERY</b>	Autonomy : about 8 hours according to intensity Micro usb charger 5V-1A included

**DIMENSIONS**

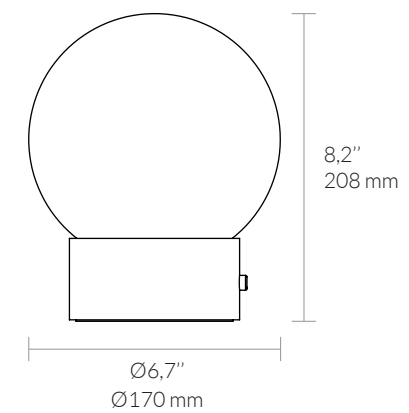

<b>WEIGHT</b>	7 lb / 3 kg
---------------	-------------

# GAMA

.édition

Iconic GAMA reinterprets the table lamp in contemporary fashion, in a play of curves and sleek lines. As for a classic lamp, Iconic GAMA consists of a base and a lampshade, separated by a delicate golden brass trim. The edges are fine and precise; the perfect proportions. The illuminated upper body magnifies the essential beauty of alabaster, providing a timeless elegance to this creation.

GAMA nomadic lamp, the little sister of our homonymous table lamps, diffuses a smooth and soothing light and follows you everywhere thanks to its autonomy.



GAMA  
.édition

NOMADIC LAMP



GAMA  
.édition

NOMADIC LAMP



GAMA  
.édition

NOMADIC LAMP



GAMA  
.édition

NOMADIC LAMP



# GAMA

.édition

NOMADIC LAMP



<b>REFERENCE</b>	ED-0013
<b>REFERENCE WITH UL LISTED CHARGER</b>	ED-0015
<b>ENVIRONNEMENT</b>	Indoor
<b>MATERIALS</b>	Alabaster, brass and painted steel
<b>LIGHT SOURCE</b>	Variable intensity LED Color temperature : 3000K
<b>LIGHT SWITCH</b>	Brass button integrated to the lamp : sensitive switch / dimmer.
<b>BATTERY</b>	Autonomy : about 8 hours according to intensity Micro usb charger 5V-1A included

**DIMENSIONS**

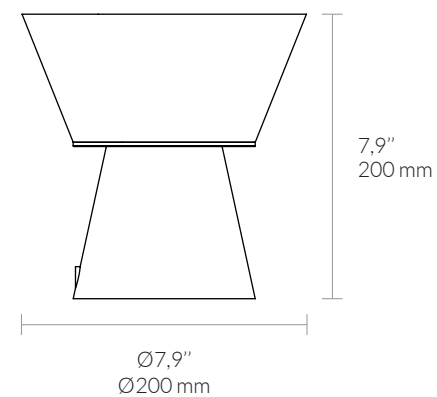

<b>WEIGHT</b>	11 lb / 5 kg
---------------	--------------

# LYRA

.édition

LYRA evokes a precious and contemporary candy jar thanks to its sleek, cylindrical design. Its surface is delicate to the touch. The elegant brass ornament serves as the lamp's dimmer and switch. LYRA diffuses a soothing light that creates a cozy, mellow atmosphere. Plug it into a power supply and it becomes your bedside lamp.



LYRA  
.édition

NOMADIC LAMP





LYRA  
.édition

NOMADIC LAMP



LYRA  
édition

NOMADIC LAMP





# LYRA

.édition

NOMADIC LAMP

<b>REFERENCE</b>	ED-0001
<b>REFERENCE WITH UL LISTED CHARGER</b>	ED-0003
<b>ENVIRONNEMENT</b>	Indoor
<b>MATERIALS</b>	Alabaster, brass and painted steel
<b>LIGHT SOURCE</b>	Variable intensity LED Color temperature : 3000K
<b>LIGHT SWITCH</b>	Brass button integrated to the lamp : sensitive switch / dimmer.
<b>BATTERY</b>	Autonomy : about 8 hours according to intensity Micro usb charger 5V-1A included

## DIMENSIONS

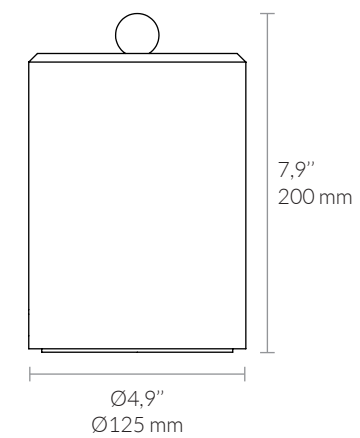

<b>WEIGHT</b>	7 lb / 3 kg
---------------	-------------

# MONA

.édition

The simple form of a half-ellipsoid. This outwardly simplistic design reveals the characteristic motion in the structure of back-lit alabaster. The clean, straight lines of the gilt brass lamp switch create a dialog with the lamp's shape. MONA draws its strength from a subdued design. The hand is irresistibly attracted to the stone and the eye is captivated by the radiant density.

MONA  
.édition

NOMADIC LAMP



# MONA

.édition

NOMADIC LAMP





MONA  
édition

NOMADIC LAMP



MONA  
.édition

NOMADIC LAMP



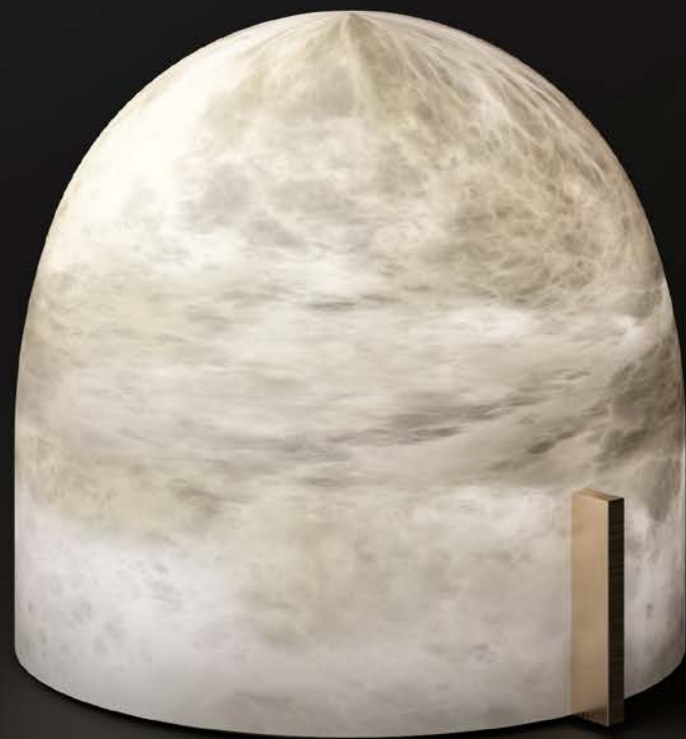

# MONA

.édition

NOMADIC LAMP

<b>REFERENCE</b>	ED-0009
<b>REFERENCE WITH UL LISTED CHARGER</b>	ED-0011
<b>ENVIRONNEMENT</b>	Indoor
<b>MATERIALS</b>	Alabaster, brass and painted steel
<b>LIGHT SOURCE</b>	Variable intensity LED Color temperature : 3000K
<b>LIGHT SWITCH</b>	Brass button integrated to the lamp : sensitive switch / dimmer.
<b>BATTERY</b>	Autonomy : about 8 hours according to intensity Micro usb charger 5V-1A included

## DIMENSIONS

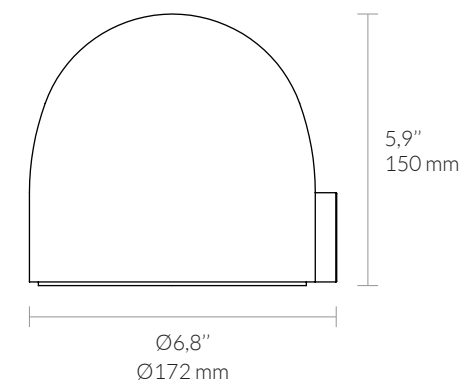

<b>WEIGHT</b>	7lb / 3kg
---------------	-----------



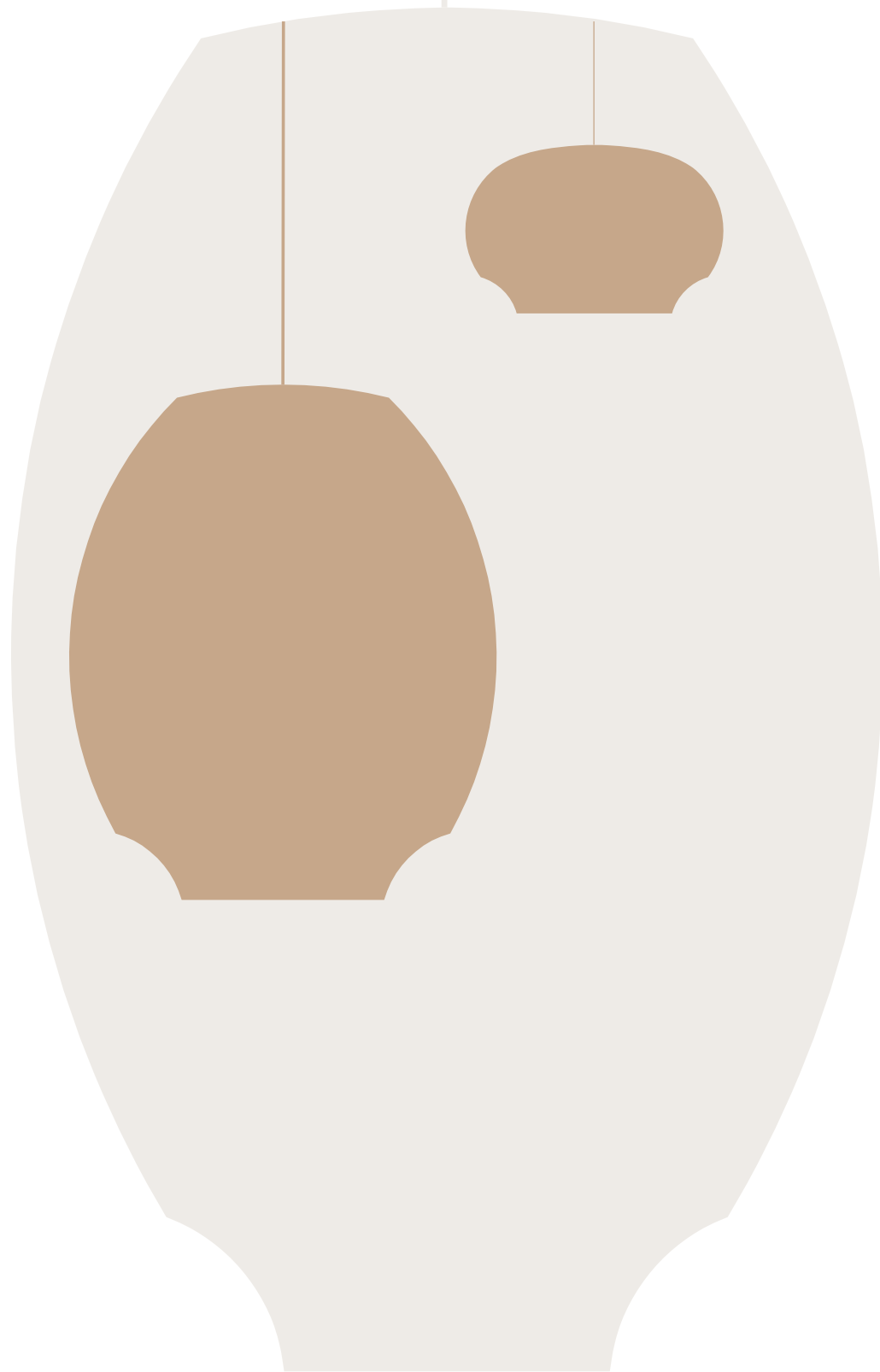

# FAMILIES

## COHERENCE AND UNITY IN MATERIAL AND DESIGN

Families are sets of varying types and formats of lighting elements that share a likeness in style. You can coordinate and compose them in a dynamic, harmonious expression.

This concept of families was inaugurated with the trio Divines, pendant lights based on a common profile designed in varying sizes. With its nomadic table lamps, wall lighting and pendant lights, the Iconic set offers all the variations of the same theme.

# DIVINES

With their evocative names, CAMILLE, CELINE and COLETTE embody feminine curves. The Divines are voluptuous pendant lights. Sharing the simplicity of alabaster stone and the subtlety of their geometric profile, only their proportions vary. Their direct radiance is combined with the magic of alabaster stone's diffused light. As a composition, they sublimate interiors such as a dining room table or a restaurant room with elegance and delicacy.



COLETTE

CELINE

CAMILLE



CAMILLE

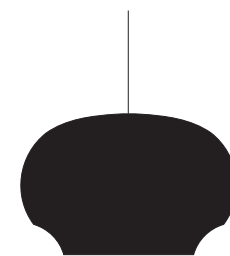

CELINE

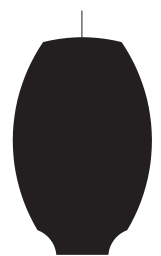

COLETTE

# ICONIC

Iconic pays homage to contemporary architecture as it adopts all its codes. This family of alabaster light fixtures is a construction game based on a simple, unconventional shape, the conical alabaster trunk. As a coherent family with similar lines, Iconic has four distinct designs: LAB, FLO, PLI and GAMA. Each of these designs comes in different types of light fixtures with various formats.





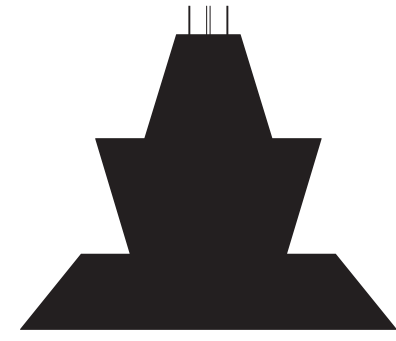

LAB s51



LAB s18



FLO s



PLI s

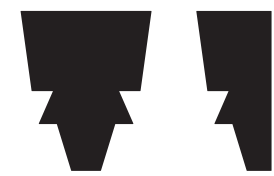

LAB A



FLO A



PLI A



GAMA L26

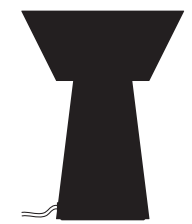

GAMA L36



GAMA



**ATELIER ALAIN ELLOUZ**  
PARIS

ALABASTER & ROCK CRYSTAL WORKSHOP

Stone and light. Two extremes in unison.  
Atelier Alain Ellouz luminaires are uniquely poetic. Fascinating pieces transcended by light reveal the extraordinary hidden richness of alabaster. In a remarkable ode to nature, space and time, they inspire contemplation and enhance any interior.

## ALABASTER



Every Atelier Alain Ellouz **.édition** luminaire is made from naturally translucent alabaster stone. Blocks are extracted from quarries, then carefully selected, sculpted, sanded and fitted with an internal light. The stone develops warm, white nuances that cloak a room in an inviting light.

Used early on to create window panes, sculptures or decorative elements, alabaster has always been a symbol of tranquility. By introducing this stone into contemporary design, Atelier Alain Ellouz shares its boundless variations and intimate qualities.

Crafted from natural material, each of our luminaires is unique. We invite you to contemplate their beauty.



## ATELIER ALAIN ELLOUZ SIGNATURE

“Today’s  
contemporary  
pieces will be  
sought after  
by tomorrow’s  
collectors.”

Alain Ellouz

Your **.édition** lamp was hand-crafted in our workshops with the same standards of excellence and pure tradition as leading French luxury brands. Each lamp is made using small, white, alabaster stone blocks carefully selected by our stone craftsmen. That’s why each one of our lamps is unique, with its own patterns and transparency.

Every one of our designs carries the Atelier Alain Ellouz signature logo and classic style. A timeless design based on pure lines in an expression of sleek elegance. A unique style of alabaster stonecraft, recognizable anywhere in the world.

Once you have acquired an Atelier Alain Ellouz piece, you can register your luminaire and receive an authenticity certificate.



## ATELIER ALAIN ELLOUZ



"Gemme" - exclusive creation for the Chaumet boutiques



INFINITY 08 V, icon of the INFINITY SCULPTURAL collection

As a true artisan of stone, Alain Ellouz masters its qualities and builds on its flaws to transform what seems ordinary into a jewel. In 2005, he began his quest to reveal the hidden treasure of each unique stone. Since then, he has been the inspiration and impetus behind the workshop's creations.

Atelier Alain Ellouz opts for radical design, out of both conviction and respect for natural materials. Alabaster and rock crystal are living stones whose intrinsic purity naturally brings them to life. In keeping with the stones' character, the workshop bases their designs on pure lines and simple forms that capture just the essential. For designers, it comes down to showcasing the stone and using sleek structures to compose new models in an ongoing commitment to expression through shape and light.

These exceptional creations are all hand-crafted, and designed with the same standards of excellence and pure tradition upheld by French luxury brands. Alain Ellouz is the first to develop this new stone craft. This innovative new art form involves the meticulous skill of sculptors and finestone craftsmen as well as the cutting-edge technologies developed to control light and preserve the qualities of alabaster. A rigorous selection of each stone, high-precision skill, unwavering commitment and superb implementation and installation make Atelier Alain Ellouz a part of France's heritage of superior craftsmen. Collaboration, dialog, rigor and pragmatism are core values applied in achieving the most ambitious projects. Atelier Alain Ellouz reinvents itself every day. And today's contemporary pieces will be sought after by collectors tomorrow.



In-workshop assembly of LYRA lamps.

Gold-etched alabaster mural panels

Finishing on bespoke table legs



Marion Biais-Sauvêtre and Alexis Jouvin



légende en anglais à mettre



INFINITY collection designs.



New York showroom - 250 m<sup>2</sup> in the heart of SOHO, Manhattan

Situated in Buc, in the French department near Versailles, Atelier Alain Ellouz is a workshop of 35 collaborators. Designers are led by Marion Biais-Sauvêtre, the true inspiration behind new pieces. Alexis Jouvin heads the design office where he continues to innovate technical solutions. Project managers orchestrate ambitious projects. Sculptors explore sculptural forms and unique textures to create dialog between shape and light.

Finestone craftsmen then work the stone in the tradition of wood cabinet-makers - layouts, cuts, assemblies, inlays, etc. Lastly, fitters defy the laws of gravity, assembling seamless compositions. Around the globe, they ensure the quality, safety and durability of the workshop's pieces. As a result of one success after another, our modest workshop is now burgeoning. In 2014, a showroom opened in London, followed by another in New York in 2018.

Atelier Alain Ellouz has brought alabaster stone to the forefront of luxury interior architecture. It designs bespoke projects such as exceptional luminaires, unique bar and mural back-lit compositions and luxury furnishings. These works of art decorate some of the most beautiful spaces in private homes, hotels, restaurants, luxury offices and retail stores around the world. Atelier Alain Ellouz boasts some very prestigious references, including royal palaces, luxury boutiques, and prominent hotels and restaurants. It also collaborates with globally-acclaimed designers.

**.édition** symbolizes a fresh momentum for the workshop as it seeks to offer private customers access to its elegant design through a new collection of luminaires, emblems of Atelier Alain Ellouz DNA. Handcrafted and always unique, each piece is easy to install and use. They are designed using a timeless material sculpted into contemporary shapes to reflect the style of the Atelier Alain Ellouz brand.



**ATELIER ALAIN ELLOUZ**  
PARIS

ALABASTER & ROCK CRYSTAL WORKSHOP

[EDITION.ATELIERALAINELLOUZ.COM](http://EDITION.ATELIERALAINELLOUZ.COM)



**ATELIER ALAIN ELLOUZ**  
PARIS

ALABASTER & ROCK CRYSTAL WORKSHOP

**EDITION.ATELIERALAINELLOUZ.COM**