

**NRP**

**NERO  
OPACO  
PROFONDO**

**DEEP  
MATT  
BLACK**

**OLIVARI**

Dal 1911 Olivari realizza maniglie in Italia,  
all'interno dei propri stabilimenti,  
dove si svolge l'intero ciclo produttivo.  
Partendo da barre in ottone, le maniglie vengono  
stampate, lavorate, smerigliate, lucidate,  
cromate e marchiate al laser.  
Olivari ha ottenuto le certificazioni  
ISO 9001 e ISO 14001  
e si avvale delle tecnologie più evolute,  
ma ha mantenuto tutta la sapienza artigianale  
accumulata in cento anni di storia.

Since 1911 Olivari has been manufacturing handles  
at its own factories in Italy  
where the entire production process takes place.  
Starting with brass billets, the handles are forged, milled,  
polished, buffed, chrome-plated and hallmarked with a laser.  
Olivari has attained ISO 9001  
and ISO 14001 certifications.  
Though it uses the most advanced technology,  
Olivari preserves all the artisanal wisdom  
it has accumulated in 100 years of history.

**OLIVARI** 

# Nero opaco profondo

## Deep matt black

**NP** Nero opaco / Matt black

### Abbiamo ampliato la gamma della finitura nero opaco

---

#### Verniciatura

La verniciatura, effettuata con polvere epossidica, ha uno spessore di circa 80 micron e conferisce al prodotto una finitura molto accattivante. Se usata secondo le istruzioni d'uso e manutenzione, la finitura verniciata ha una vita lunga.

L'elevata frequenza di utilizzo e l'eventuale esposizione agli agenti atmosferici possono ridurre la vita utile del prodotto.

### We have expanded the range of the matt black finish

---

#### Coating

Epoxy-based powder coating, about 80 microns thick, offers a very attractive finish with great longevity, provided the product is used in accordance with the instructions and maintenance guidelines. High-intensity use and exposure to the elements can limit the product's lifespan.

A close-up photograph of a black, L-shaped chair leg or base component. The component is made of a matte black material and is positioned on a light-colored wooden surface. The word "OLIVARI" is printed in white, uppercase letters on the vertical part of the L-shape. The lighting is warm, creating soft shadows and highlighting the texture of the wood and the smooth finish of the black plastic.

OLIVARI

A close-up photograph of a modern, black door handle. The handle is mounted on a white wall. The handle itself is a thick, rectangular bar with rounded ends, featuring a recessed grip area. The brand name "OLIVARI" is printed in a clean, white, sans-serif font on the upper part of the handle. The background is a plain, light-colored wall, and the lighting creates soft shadows, highlighting the handle's form and texture.

OLIVARI

# Icona Vincent Van Duysen

La maniglia ha un'estetica essenziale, neutra e funziona come una sorta di 'passe-partout', con un tocco di memoria ma allo stesso momento contemporanea e moderna. Abbiamo prestato molta attenzione all'ergonomia, molto piacevole nella mano grazie alla sezione stondata all'interno dell'impugnatura. Questa parte stondata contrasta con la parte piatta visibile della maniglia e crea un effetto inaspettato.

The handle has an essential neutral aesthetics and works like a sort of 'passe-partout' with a touch of memory, but it is contemporary and modern at the same time. We paid a lot of attention to ergonomics, very pleasant in the hand thanks to the rounded section inside the handle. This rounded part contrasts with the visible flat portion of the handle and creates an unexpected effect.

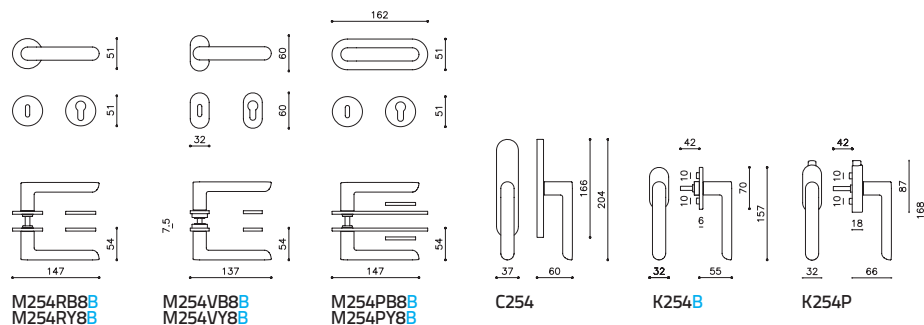

## M 254B



CR Cromo lucido/Bright chrome



NL SuperNichel lucido/  
SuperNickel bright



RS SuperRame satinato/  
SuperCopper satin



IS SuperInox satinato/  
SuperStainlessSteel satin



CO Cromo satinato/Satin chrome



NS SuperNichel satinato/  
SuperNickel satin



DS SuperBronzo satinato/  
SuperBronze satin



US SuperAntracite satinato/  
SuperAnthracite satin



NP Nero opaco/Matt black





# Lama L Gio Ponti

Nel lungo e fruttuoso rapporto di collaborazione con Olivari, Ponti mette a fuoco due tipi di approccio al disegno della maniglia. Uno, organico, più funzionale, in cui la leva si offre alla presa della mano modellandosi secondo un disegno sinuoso. L'altro, invece, geometrico, in base al quale è la mano ad adattarsi "naturalmente" alla forma. Questo secondo approccio emerse con forza quando Gio Ponti si trovò a disegnare la maniglia per il grattacielo Pirelli. Il modello che ne scaturì, Lama, condensa questa sua visione dove è la "simbologia classica" a prevalere sull'approccio "funzionale". Alla purezza geometrica della sua forma, talmente assottigliata da equipararla ad una lama fa da contrappunto la studiattissima definizione dei raggi che addolciscono il profilo tagliente dei suoi contorni sottili.

In his long and productive collaboration with Olivari, Ponti focused on two types of approach to the design of handles. One was more organic, where the lever is offered to the hand's grip as a sinuously modelled element. The other was inspired by geometric clarity, according to which the hand naturally adapts to the shape. He followed this approach when he was designing a handle for the Pirelli skyscraper in Milan. The resulting model was Lama, a condensation of his vision in which classical symbolism prevails over functionalism. The geometric simplicity of its shape, so thin as to resemble a blade (lama in Italian) offers a counterpoint to the carefully studied definition of the radii that soften the sharp profile of its flat contours.

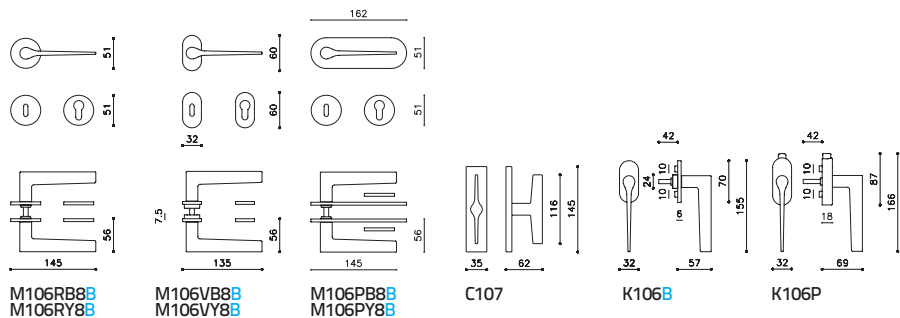

## M106B



CR Cromo lucido/Bright chrome



ZL SuperOro lucido/  
SuperGold bright



NL SuperNichel lucido/  
SuperNickel bright



RS SuperRame satinato/  
SuperCopper satin



IS SuperInox satinato/  
SuperStainlessSteel satin



CO Cromo satinato/Satin chrome



TS SuperOro satinato/  
SuperGold satin



NS SuperNichel satinato/  
SuperNickel satin



DS SuperBronzo satinato/  
SuperBronze satin



US SuperAntracite satinato/  
SuperAnthracite satin



NP Nero opaco/Matt black





# Tizianella F Sergio Asti

L'incontro con Sergio Asti, in pieno boom economico – quando il tema dello standard era al centro delle discussioni intorno all'industrial design – spinge Olivari a produrre un modello dove geometria rigorosa ed esigenze ergonomiche trovano piena espressione. Per la sua chiarezza geometrica la maniglia si è guadagnata il titolo di *long-seller* del catalogo Olivari: da quasi sessant'anni il modello Tizianella è ininterrottamente in produzione nelle sue declinazioni diverse, in termini di materiali e di variazione di finiture. *Antonio Olivari*

Olivari's encounter with Sergio Asti took place at the height of Italy's economic boom, when standardisation was at the centre of debate in the field of industrial design. This stimulated Olivari to produce a handle where strict geometry and ergonomic requirements find full expression. Thanks to its geometric clarity, the Tizianella handle has earned the title of long-seller in the Olivari product range. For almost 60 uninterrupted years, it has been in production in different versions in terms of materials and various finishes. *Antonio Olivari*

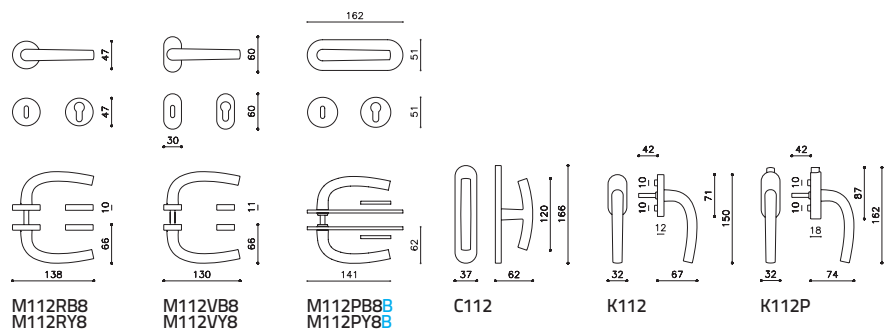

M112



CR Cromo lucido/Bright chrome



ZL SuperOro lucido/  
SuperGold bright



IS SuperInnox satinato/  
SuperStainlessSteel satin



CO Cromo satinato/Satin chrome



TS SuperOro satinato/  
SuperGold satin



NP Nero opaco/Matt black



# Uovo Studio Olivari

Il modello Uovo è stato ideato da Ambrogio Olivari. Occorreva un pomolo piccolo, dalla forma elegante e per ottenerlo, come rivela il nome, ha semplicemente utilizzato un uovo. Per la realizzazione si è preferito optare sulla fusione in conchiglia con anima in sabbia, una tecnica che consentiva di ottenere un'ampia superficie esterna e un corpo internamente cavo: per ridurre il materiale, contenere i costi e anche il peso (in modo da non gravare sulla serratura). Il modello ha avuto grande successo ed è ancora a catalogo.

The Uovo (Italian for "egg") is the brainchild of Ambrogio Olivari. We needed a small knob with an elegant shape. To obtain it, as the name reveals, he simply used an egg. To produce it, we cast it using shell moulding with a sand core, a technique that allowed us to achieve a large exterior surface and a hollow body. This reduced the amount of material needed, lowered costs and lightened the weight (in order to not weigh down on the mechanism). The model was extremely successful and is still part of our range.

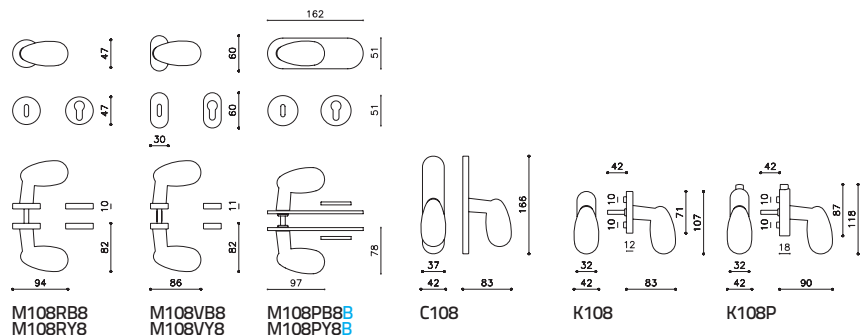

## M108



CR Cromo lucido/Bright chrome



ZL SuperOro lucido/  
SuperGold bright



DS SuperBronzo satinato/  
SuperBronze satin



CO Cromo satinato/Satin chrome



TS SuperOro satinato/  
SuperGold satin



NP Nero opaco/Matt black





OLIVIA

# Lotus / Lotus Q Javier Lopez

Quando, giovane designer, mi sono presentato ai fratelli Olivari proponendo una maniglia al limite della scomparsa, questa idea ha subito raccolto la loro adesione, spingendoli ad appassionarsi al suo sviluppo. Non era facile. Il profilo sottile della leva doveva entrare in relazione con lo spessore della rosetta. Nel ricordare forme e superfici lungo il piano orizzontale nel modo più fluido possibile, siamo riusciti a disegnare una maniglia quasi inesistente, per così dire. *Javier Lopez*

As a young designer, I introduced myself to the Olivari brothers by proposing a handle so minimal, it almost disappeared. The idea won them over immediately, and they enthusiastically lent their support to develop it. It wasn't easy. The thin profile of the lever needed to enter into a relationship with the thickness of the rose. By joining the forms and surfaces along the horizontal plane in the most fluid way possible, we succeeded in designing a handle that we could describe as being quasi non-existent. *Javier Lopez*

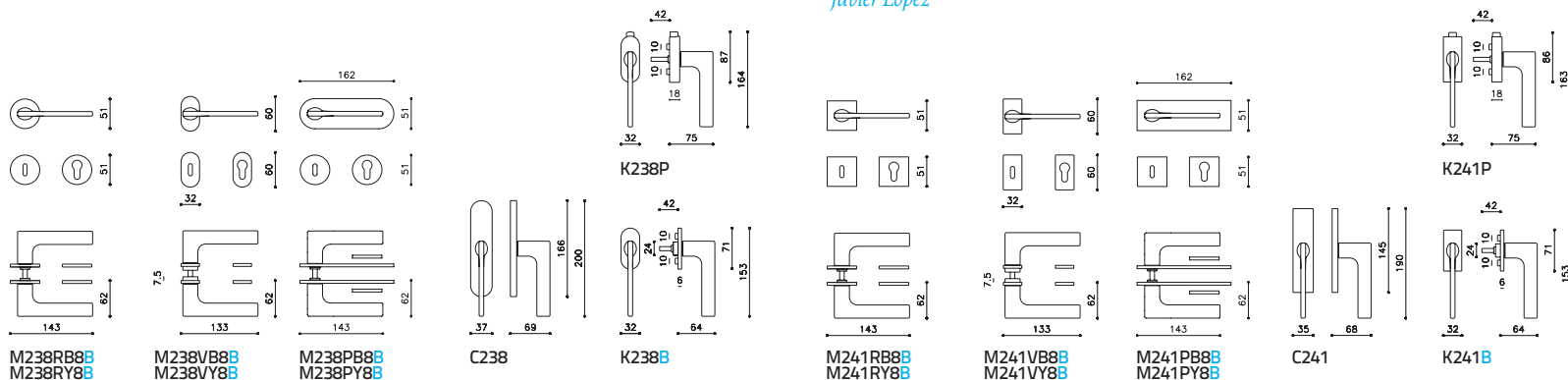

M241B



CR Cromo lucido/Bright chrome



TS SuperOro satinato/  
SuperGold satin



NL SuperNichel lucido/  
SuperNickel bright



RS SuperRame satinato/  
SuperCopper satin



NP Nero opaco/Matt black



CO Cromo satinato/Satin chrome



IS SuperInox satinato/  
SuperStainlessSteel satin



NS SuperNichel satinato/  
SuperNickel satin



DS SuperBronzo satinato/  
SuperBronze satin



US SuperAntracite satinato/  
SuperAnthracite satin





# Planet B / Planet QB

Luca Casini

La maniglia Planet è nata in un'epoca in cui il modello "squadro" di maniglia non era ancora apparso sul mercato come protagonista. Ero attratto dall'idea di realizzare una maniglia lineare e apparentemente spigolosa ma in realtà morbida all'impugnatura, con superfici impercettibilmente curve e una proporzione ideale dei volumi in termini estetici e funzionali. Ne è nata una sezione rettangolare ammorbidita dalla raggiatura degli spigoli che non solo migliora l'ergonomia ma facilita anche la riproducibilità per stampaggio. Oggi dopo tanti anni di produzione è motivo di orgoglio constatare come sia un prodotto di riferimento per il settore, tanto da essere utilizzata in molte importanti architetture contemporanee. *Luca Casini*

The Planet was born at a time when the squared handle model had not yet appeared on the market as a protagonist. I was attracted by the idea of creating a linear and seemingly sharp-edged handle that in reality felt soft to the grip, with imperceptibly curved surfaces and an ideal proportion of volumes in terms of aesthetics and functionality. From this came a rectangular section, softened by rounded edges, which not only improves the ergonomics, but also facilitates the handle's producibility by moulding. Now, after many years of production, it is a source of pride to see how it has become a reference model among handles, to the extent that it is used in many important instances of contemporary architecture. *Luca Casini*

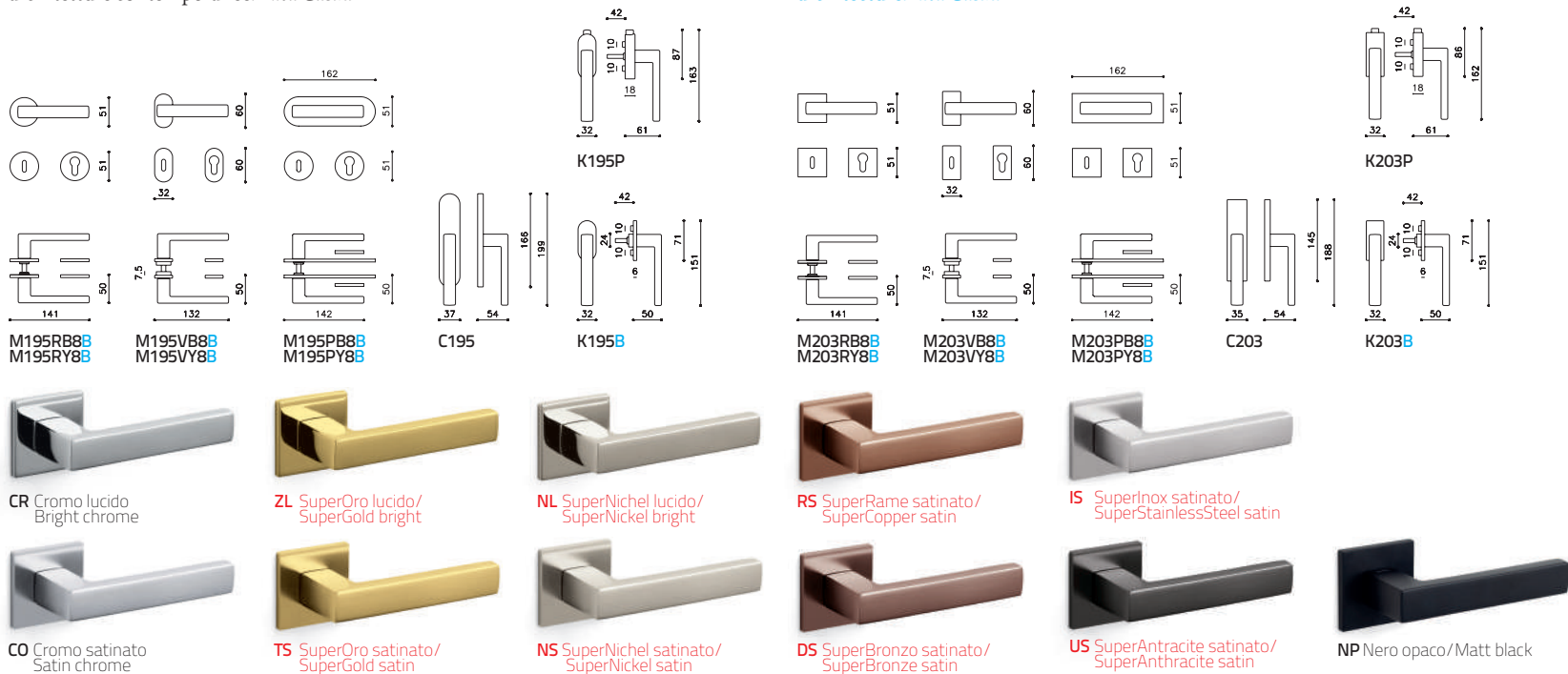



# pomoli centrali / central door knobs

Diana Studio Olivari



## ottone/brass

- CR Cromo lucido/Bright chrome
- CO Cromo satinato/Satin chrome
- NP Nero opaco/Matt Black
- ZL SuperOro lucido/SuperGold bright
- TS SuperOro satinato/SuperGold satin
- NL SuperNichel lucido/  
SuperNickel bright
- NS SuperNichel satinato/  
SuperNickel satin
- IS SuperInox satinato/  
SuperStainlessSteel satin
- RS SuperRame satinato/  
SuperCopper satin
- DS SuperBronzo satinato/  
SuperBronze satin
- US SuperAntracite satinato/  
SuperAnthracite satin

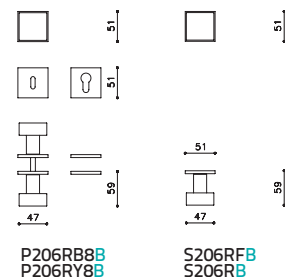

P206B

Link Piero Lissoni



**ottone/brass**

- CR Cromo lucido/Bright chrome
- CO Cromo satinato/Satin chrome
- NP Nero opaco/Matt Black
- ZL SuperOro lucido/SuperGold bright
- TS SuperOro satinato/SuperGold satin
- NL SuperNichel lucido/  
SuperNickel bright
- NS SuperNichel satinato/  
SuperNickel satin
- IS SuperInox satinato/  
SuperStainlessSteel satin
- RS SuperRame satinato/  
SuperCopper satin
- DS SuperBronzo satinato/  
SuperBronze satin
- US SuperAntracite satinato/  
SuperAnthracite satin

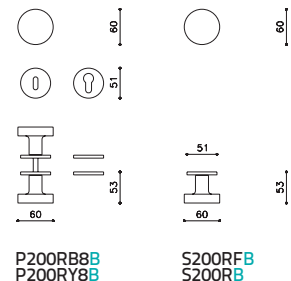

P200B

# chiavistelli / latches

## Link S Piero Lissoni



H199B6

## Space S Studio Olivari



H192B6

## Verona S Studio Olivari



H105B6

### ottone/brass

- CR Cromo lucido/Bright chrome
- CO Cromo satinato/Satin chrome
- NP Nero opaco/Matt Black
- ZL SuperOro lucido/SuperGold bright
- TS SuperOro satinato/SuperGold satin
- NL SuperNichel lucido/SuperNickel bright
- NS SuperNichel satinato/SuperNickel satin
- IS SuperInox satinato/SuperStainlessSteel satin
- RS SuperRame satinato/SuperCopper satin
- DS SuperBronzo satinato/SuperBronze satin
- US SuperAntracite satinato/SuperAnthracite satin

## Link Piero Lissoni

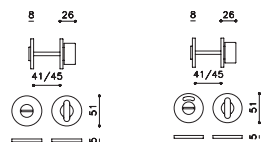

H200V6B

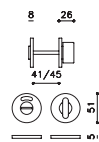

H200VF6B

## Space Studio Olivari

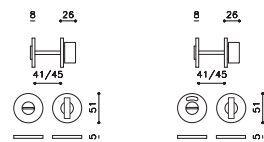

H193V6B

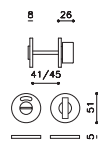

H193VF6B

## Verona V Studio Olivari

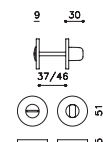

H106V6B

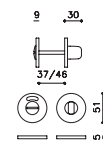

H106VF6B

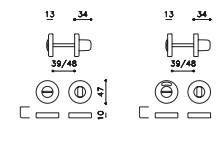

H106V6

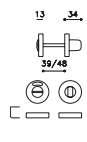

H109V6

## Link Q Piero Lissoni

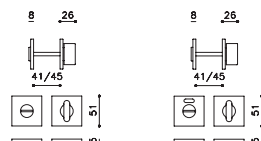

H209V6B

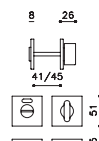

H209VF6B

## Space Q Studio Olivari

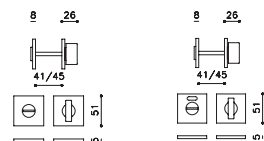

H202V6B

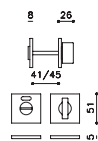

H202VF6B

## Verona Q Studio Olivari

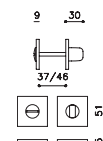

H117V6B

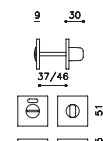

H117VF6B

H199B6



H192B6



H200VF6B



H193VF6B



H209V6B



H202V6B



## maniglie incasso / flush handles

### Giotto Q Studio Olivari



#### ottone/brass

- CR Cromo lucido/Bright chrome
- CO Cromo satinato/Satin chrome
- CA Cromo lucido-satinato/  
Chrome bright-satin
- NP Nero opaco/Matt Black
- ZL SuperOro lucido/SuperGold bright
- TS SuperOro satinato/SuperGold satin
- NL SuperNichel lucido/  
SuperNickel bright
- NS SuperNichel satinato/  
SuperNickel satin
- IS SuperInox satinato/  
SuperStainlessSteel satin
- RS SuperRame satinato/  
SuperCopper satin
- DS SuperBronzo satinato/  
SuperBronze satin
- US SuperAntracite satinato/  
SuperAnthracite satin

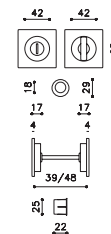

D127

### Dante Studio Olivari



#### ottone/brass

- CR Cromo lucido/Bright chrome
- CO Cromo satinato/Satin chrome
- CA Cromo lucido-satinato/  
Chrome bright-satin
- NP Nero opaco/Matt Black
- ZL SuperOro lucido/SuperGold bright
- TS SuperOro satinato/SuperGold satin
- NL SuperNichel lucido/  
SuperNickel bright
- NS SuperNichel satinato/  
SuperNickel satin
- IS SuperInox satinato/  
SuperStainlessSteel satin
- RS SuperRame satinato/  
SuperCopper satin
- DS SuperBronzo satinato/  
SuperBronze satin
- US SuperAntracite satinato/  
SuperAnthracite satin

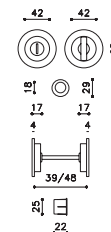

D132



Siro Studio Olivari



D111

Vico Studio Olivari

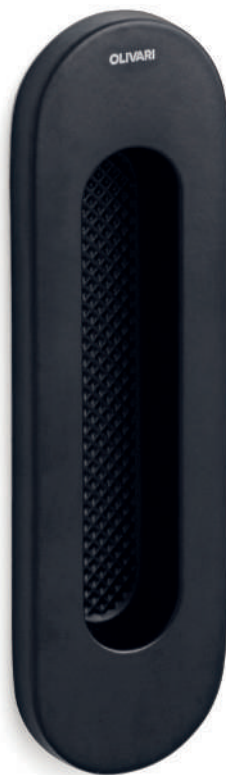

D109

**ottone/brass**

- CR Cromo lucido/Bright chrome
- CO Cromo satinato/Satin chrome
- NP Nero opaco/Matt Black
- ZL SuperOro lucido/SuperGold bright
- TS SuperOro satinato/SuperGold satin
- NL SuperNichel lucido/  
SuperNickel bright
- NS SuperNichel satinato/  
SuperNickel satin
- IS SuperInox satinato/  
SuperStainlessSteel satin
- RS SuperRame satinato/  
SuperCopper satin
- DS SuperBronzo satinato/  
SuperBronze satin
- US SuperAntracite satinato/  
SuperAnthracite satin

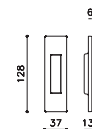

D111

**ottone/brass**

- CR Cromo lucido/Bright chrome
- CO Cromo satinato/Satin chrome
- NP Nero opaco/Matt Black
- ZL SuperOro lucido/SuperGold bright
- TS SuperOro satinato/SuperGold satin
- NL SuperNichel lucido/  
SuperNickel bright
- NS SuperNichel satinato/  
SuperNickel satin
- IS SuperInox satinato/  
SuperStainlessSteel satin
- RS SuperRame satinato/  
SuperCopper satin
- DS SuperBronzo satinato/  
SuperBronze satin
- US SuperAntracite satinato/  
SuperAnthracite satin

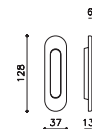

D109

# maniglioni / pull handles

## Diana Studio Olivari

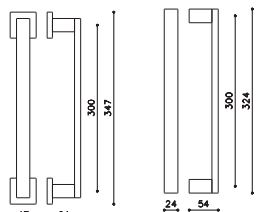

L206R

L206

## Link Pietro Lissoni

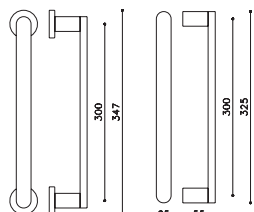

L199R

L199

### ottone/brass

- CR Cromo lucido/Bright chrome
- CO Cromo satinato/Satin chrome
- NP Nero opaco/Matt Black
- NL SuperNichel lucido/  
SuperNickel bright
- IS SuperInox satinato/  
SuperStainlessSteel satin
- RS SuperRame satinato/  
SuperCopper satin
- DS SuperBronzo satinato/  
SuperBronze satin
- US SuperAntracite satinato/  
SuperAnthracite satin



L206R



L206



L199R



L199

# maniglioni alzanti / pull-up handles

## Planet Q Studio Olivari

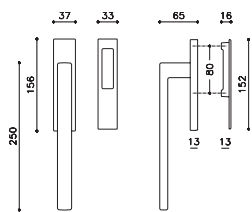

L121

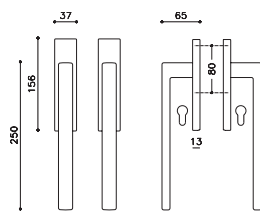

L122

## Planet Studio Olivari

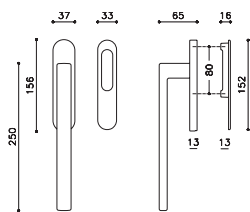

L111

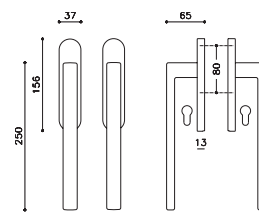

L112

### ottone/brass

- CR Cromo lucido/Bright chrome
- CO Cromo satinato/Satin chrome
- NP Nero opaco/Matt Black
- ZL SuperOro lucido/SuperGold bright
- TS SuperOro satinato/SuperGold satin
- NL SuperNichel lucido/SuperNickel bright
- NS SuperNichel satinato/SuperNickel satin
- IS SuperInox satinato/SuperStainlessSteel satin
- RS SuperRame satinato/SuperCopper satin
- DS SuperBronzo satinato/SuperBronze satin
- US SuperAntracite satinato/SuperAnthracite satin

## Lotus Q Javier Lopez

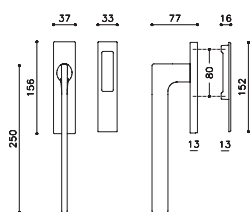

L221

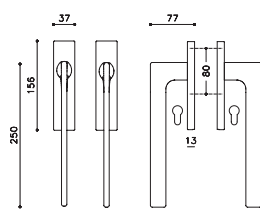

L222

## Lotus Javier Lopez

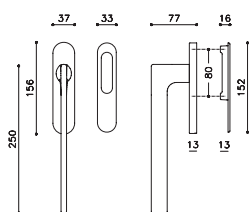

L211

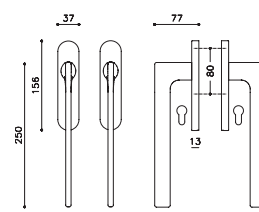

L212

### ottone/brass

- CR Cromo lucido/Bright chrome
- CO Cromo satinato/Satin chrome
- NP Nero opaco/Matt Black
- ZL SuperOro lucido/SuperGold bright
- TS SuperOro satinato/SuperGold satin
- NL SuperNichel lucido/SuperNickel bright
- NS SuperNichel satinato/SuperNickel satin
- IS SuperInox satinato/SuperStainlessSteel satin
- RS SuperRame satinato/SuperCopper satin
- DS SuperBronzo satinato/SuperBronze satin
- US SuperAntracite satinato/SuperAnthracite satin

## Lama Gio Ponti

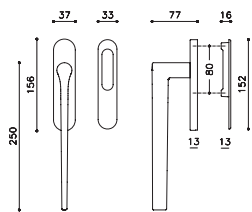

L136

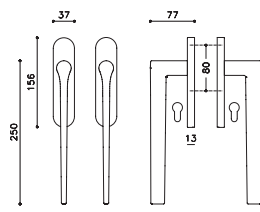

L137

## Link Piero Lissoni

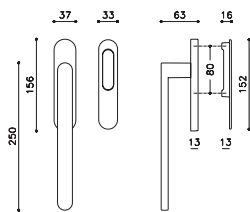

L126

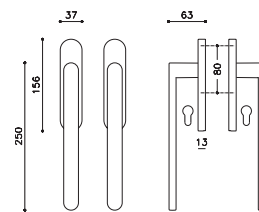

L127

### ottone/brass

- CR Cromo lucido/Bright chrome
- CO Cromo satinato/Satin chrome
- NP Nero opaco/Matt Black
- ZL SuperOro lucido/SuperGold bright
- TS SuperOro satinato/SuperGold satin
- NL SuperNichel lucido/SuperNickel bright
- NS SuperNichel satinato/SuperNickel satin
- IS SuperInox satinato/SuperStainlessSteel satin
- RS SuperRame satinato/SuperCopper satin
- DS SuperBronzo satinato/SuperBronze satin
- US SuperAntracite satinato/SuperAnthracite satin



L121



L221



L136



L126

# Fermaporte / Door stoppers

Cubo Studio Olivari

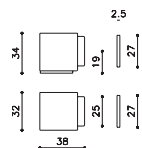

**B136C**  
MAGNETICO/  
MAGNETIC

**B136S**  
NON MAGNETICO/  
NOT MAGNETIC

## ottone/brass

- CR Cromo lucido/Bright chrome
- CO Cromo satinato/Satin chrome
- NP Nero opaco/Matt Black
- ZL SuperOro lucido/SuperGold bright
- TS SuperOro satinato/SuperGold satin
- NL SuperNichel lucido/SuperNickel bright
- NS SuperNichel satinato/SuperNickel satin
- IS SuperInox satinato/SuperStainlessSteel satin
- RS SuperRame satinato/SuperCopper satin
- DS SuperBronzo satinato/SuperBronze satin
- US SuperAntracite satinato/SuperAnthracite satin

Victor Studio Olivari

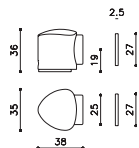

**B106C**  
MAGNETICO/  
MAGNETIC

**B106S**  
NON MAGNETICO/  
NOT MAGNETIC

## ottone/brass

- CR Cromo lucido/Bright chrome
- CO Cromo satinato/Satin chrome
- NP Nero opaco/Matt Black
- ZL SuperOro lucido/SuperGold bright
- TS SuperOro satinato/SuperGold satin
- NL SuperNichel lucido/SuperNickel bright
- NS SuperNichel satinato/SuperNickel satin
- IS SuperInox satinato/SuperStainlessSteel satin
- RS SuperRame satinato/SuperCopper satin
- DS SuperBronzo satinato/SuperBronze satin
- US SuperAntracite satinato/SuperAnthracite satin

## Raffaella Studio Olivari



B102

### ottone/brass

CR Cromo lucido/Bright chrome  
CO Cromo satinato/Satin chrome  
NP Nero opaco/Matt Black  
ZL SuperOro lucido/SuperGold bright  
TS SuperOro satinato/SuperGold satin  
NL SuperNichel lucido/SuperNickel bright  
NS supernichel satinato/SuperNickel satin  
IS SuperInox satinato/SuperStainlessSteel satin  
RS SuperRame satinato/SuperCopper satin  
DS SuperBronzo satinato/SuperBronze satin  
US SuperAntracite satinato/SuperAnthracite satin

## Stilo Studio Olivari

### ottone/brass

CR Cromo lucido/Bright chrome  
CO Cromo satinato/Satin chrome  
NP Nero opaco/Matt Black  
ZL SuperOro lucido/SuperGold bright



B121

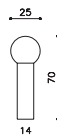

B123  
DA PARETE/  
FOR WALL

### ottone/brass

CR Cromo lucido/Bright chrome  
CO Cromo satinato/Satin chrome  
NP Nero opaco/Matt Black  
ZL SuperOro lucido/SuperGold bright



## Concept and graphic

Marco Strina

## Photo

Sauro Sorana

Andrea Andreini

## Printed in Italy

Galli Thierry\_ Milano 2021

## Olivari B. spa

Via Giacomo Matteotti, 140  
28021 Borgomanero NO Italy  
T +39 0322 835080  
F +39 0322 846484  
olivari@olivari.it  
www.olivari.it

Il catalogo è soggetto ad aggiornamenti.  
Ci riserviamo di apportare qualsiasi modifica ai prodotti e di eliminarli dalla produzione, senza obbligo di preavviso. Dati, misure o schemi hanno solamente carattere informativo e non sono vincolanti.

Eventuali errori e/o refusi di stampa non costituiscono motivo di contestazione.

Modelli e marchi depositati. Tutti i diritti riservati © OLIVARI B. s.p.a.

I prodotti OLIVARI sono tutelati da brevetto in Europa e in molti paesi extra UE.

Al fine di evitare contraffazioni, marchiamo al laser tutte le maniglie sia con il logo OLIVARI sulla leva che con il codice identificativo del lotto e la data di produzione sul collarino. Questa marcatura indelebile, certifica che il prodotto è realizzato in ambito ISO 9001 e ne consente la tracciabilità. Invitiamo i clienti a diffidare da prodotti "tipo OLIVARI" e ad acquistare solo prodotti originali "OLIVARI".

*We reserve the right to modify and discontinue any products, without prior notice. Data sheets, measurements or patterns are only for information and are not binding. Any misprints do not allow raise objections. Registered trademarks and patented designs. All rights reserved © Olivari B. s.p.a.*

*OLIVARI products are registered and patented in Europe and many countries extra UE. In order to avoid counterfeits, we laser-mark all the door handles both with the OLIVARI logo on the lever and with the identification code of the lot and the date of production on the neck. This indelible marking, certifies that the product is made in ISO 9001 and allows traceability. We invite customers to beware of "OLIVARI type" products and to buy only "OLIVARI" original products.*



Questo catalogo è stato stampato su carta Sirio Ultra Black e GardaMatt Art certificata FSC, prodotta con cellulosa proveniente da foreste gestite in maniera sostenibile per l'ambiente. L'energia necessaria per la stampa è stata prodotta da un impianto fotovoltaico. Il contributo all'ambiente è il seguente: CO<sub>2</sub> non immessa in atmosfera 79.645 kg/year, petrolio risparmiato 42.063 l/year, alberi equivalenti 159 trees/year.

*This catalog was printed on paper Sirio Ultra Black and GardaMatt Art FSC certified, produced with cellulose from forests managed in a sustainable way for the environment. The energy for printing was totally produced by a photovoltaic system. The contribution to the environment is the following: CO<sub>2</sub> not released into the atmosphere 79.645 kg / year, oil saved 42.063 l / year, trees equivalent 159 trees / year.*





