

fase m



Ricerca tecnologica, materiali di alta qualità, artigianalità e stile. Sono questi i fattori che caratterizzano il progetto di un prodotto Fasem, dando vita ad un oggetto di design che deve far coesistere forma e contenuto, estetica e funzionalità. Creiamo prodotti interamente fatti a mano in Toscana dove la lavorazione della pelle e del cuoio hanno una sede fra le più antiche e riconosciute nel mondo. Da oltre 50 anni Fasem è presente sul mercato. Una lunga storia che parte dalle lavorazioni di parti metalliche per sedie e avvicinandosi dagli anni '80 al design. Al prodotto finito. Una collezione di articoli mai banali fatti per durare nel tempo e che donano agli spazi un'atmosfera calda, inclusiva e preziosa.

*Ricerca tecnologica, materiali di alta qualità, artigianalità e stile. Sono questi i fattori che caratterizzano il progetto di un prodotto Fasem, dando vita ad un oggetto di design che deve far coesistere forma e contenuto, estetica e funzionalità. Creiamo prodotti interamente fatti a mano in Toscana dove la lavorazione della pelle e del cuoio hanno una sede fra le più antiche e riconosciute nel mondo. Da oltre 50 anni Fasem è presente sul mercato. Una lunga storia che parte dalle lavorazioni di parti metalliche per sedie e avvicinandosi dagli anni '80 al design. Al prodotto finito. Una collezione di articoli mai banali fatti per durare nel tempo e che donano agli spazi un'atmosfera calda, inclusiva e preziosa.*



HOME

AIRLUX BC	PG. 8 - 11
AIRLUX BT	PG. 12 - 13
AIRLUX BAR	PG. 14 - 17
ANDE	PG. 18 - 23
ANDE TALL	PG. 24 - 25
AVION	PG. 26 - 29
AVION PELLE	PG. 30 - 33
BONA	PG. 34 - 37
CAYMAN BAR BT	PG. 38 - 43
CAYMAN BAR POLI BT	PG. 44 - 45
CHARM	PG. 46 - 51
CROP	PG. 52 - 55
ELECTA BC	PG. 56 - 61
ELECTA TALL BC	PG. 62 - 63
ELECTA BAR BT	PG. 64 - 67
ELECTA LOUNGE	PG. 68 - 71
ELECTA RELAX	PG. 72 - 75
FETTUCCINI P	PG. 76 - 81
FETTUCCINI W	PG. 82 - 85
FIORILE	PG. 86 - 89
FIORILE BAR BT	PG. 90 - 91
FIORILE PLISSÉ BC	PG. 94 - 95
FIORILE BAR PLISSÉ BT	PG. 96 - 99
FIORILE PLISSÉ BT	PG. 100 - 101
FIORILE LOUNGE PLISSÉ BC	PG. 102 - 107
LOLA	PG. 108 - 113

HOME

LYS P	PG. 114 - 117
LYS W	PG. 118 - 121
NET W	PG. 122 - 127
O'MIES	PG. 128 - 133
P40	PG. 134 - 137
P90	PG. 138 - 143
RELAIX P	PG. 144 - 147
RELAIX S	PG. 148 - 149
RELAIX BAR	PG. 150 - 151
REST	PG. 152 - 157
RIO	PG. 158 - 163
S44	PG. 164 - 167
S91	PG. 168 - 171
S92	PG. 172 - 177

TAVOLI E COMPLEMENTI

ADELE	PG. 179 - 183
ADELE C	PG. 184 - 185
ALIANTE	PG. 186 - 189
ANTIMO	PG. 190 - 197
CRAB	PG. 198 - 205
ELECTA COFFEE TABLE	PG. 206
ELECTA SIDE TABLE	PG. 207
FLAVIO	PG. 208 - 211
LUX	PG. 212 - 215
MEZZÈ	PG. 216 - 219
ROLLING	PG. 220 - 223
ROLLING 2B	PG. 224 - 225

OFFICE

ABACO E ALA	PG. 228 - 231
ADELE	PG. 232 - 233
ADELE C DESK	PG. 234 - 235
AIRLUX BC	PG. 236 - 237
ALIANTE	PG. 238 - 239
ELECTA BC	PG. 240
ELECTA BG	PG. 241
ELECTA TALL BC	PG. 242 - 243
ELECTA TALL BG	PG. 244 - 245
FLAVIO	PG. 246 - 247
FOSCA BIG ABF	PG. 248 - 251
FOSCA BIG ABW	PG. 252 - 253
FOSCA BIG TALL ABW	PG. 254 - 255
LUNA ABW	PG. 256 - 257
NORMAN D ABW	PG. 258 - 259
P40	PG. 260 - 261
P90	PG. 262 - 263
RELAIX ABW	PG. 264 - 267
ROLLING 2B	PG. 268 - 269
ROLLING DESK	PG. 270 - 273
TRESOR ABW	PG. 274 - 279
DISEGNI TECNICI	PG. 280



faseem

HOME

# AIRLUX

design  
Noé Duchaufour Lawrance



## AIRLUX BC

Forma e funzione lavorano all'unisono.  
Lo schienale imbottito in pelle, fissato sulla struttura rivestita in cuoio,  
segue la sua forma curva e avvolgente dando vita  
ad una confortevole poltrona con base girevole realizzata in acciaio  
e disponibile in varie finiture verniciate o galvaniche.



Cuoio pieno fiore 22 Avorio  
Full grain hide leather 22 Ivory  
Pelle effetto morbido 522 Avorio  
Soft leather smooth effect 522 Ivory  
Base 400 Cromo lucido  
Base 400 Shiny chrome



Cuoio pieno fiore 30 Verde inglese  
Full grain hide leather 30 English green  
Pelle effetto morbido 519 Verde  
Soft leather smooth effect 519 Green  
Base 460 Ottone opaco  
Base 460 Matt brass



## AIRLUX BT

Poltrona con base girevole rotonda ad altezza fissa.  
Perfetta in qualsiasi ambiente.  
Solidità e forme morbide caratterizzano questo modello in pelle e cuoio.



Cuoio pieno fiore 01 Tabacco  
Full grain hide leather 01 Tobacco  
Pelle effetto morbido 679 Tabacco  
Soft leather smooth effect 679 Tobacco  
Base 495 Bronzo opaco  
Base 495 Matt bronze

Cuoio pieno fiore 01 Tabacco  
Full grain hide leather 01 Tobacco  
Pelle effetto morbido 679 Tabacco  
Soft leather smooth effect 679 Tobacco  
Base 495 Bronzo opaco  
Base 495 Matt bronze

AIRLUX BAR





## AIRLUX BAR

Forme generose per un modello accogliente e cucito sui bisogni di comfort ed estetica. Caratterizzato da un' esclusiva seduta spaziosa è dotato di una stabile struttura girevole in acciaio trattabile in varie finiture. Ha altezza regolabile e base rotonda. Maniglia di regolazione rivestita in cuoio pieno fiore.



Cuoio pieno fiore 32 Grigio argilla  
Full grain hide leather 32 Clay grey  
Pelle effetto morbido 506 Grigio  
Soft leather smooth effect col. 506 Grey  
Base 444 Nichel nero  
Base 444 Black nickel

Cuoio pieno fiore 22 Avorio  
Full grain hide leather 22 Ivory  
Pelle effetto morbido 522 Avorio  
Soft leather smooth effect 522 Ivory  
Base 400 Cromo lucido  
Base 400 Shiny chrome



ANDE  
design  
Jeff Miller

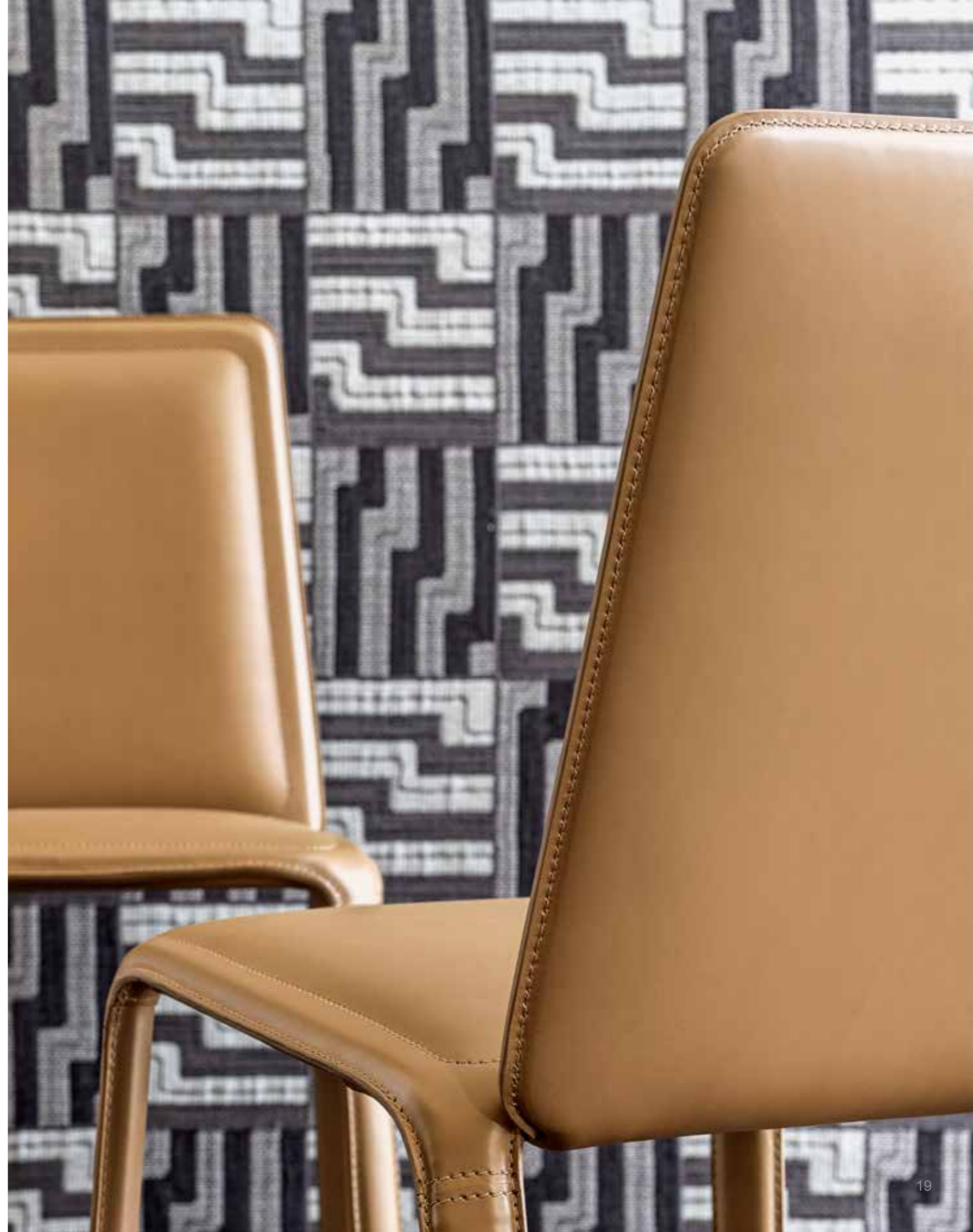



Cuoio pieno fiore 01 Tabacco  
Full grain hide leather 01 Tobacco



## ANDE

Eleganza sartoriale.  
Sedia dalle forme morbide con una struttura in acciaio  
completamente rivestita in cuoio.



## ANDE TALL

Ande nella versione con schienale alto.

La linea asciutta e raffinata, le proporzioni insolite e l'assenza di spigoli donano a questa sedia un grande appeal.



AVION  
design  
Archirivolto



Seduta tessuto bouclé B001 Avorio  
Sitting bouclé fabric B001 Ivory  
Cuoio pieno fiore 22 Avorio  
Full grain hide leather 22 Ivory  
Base 1013 Avorio opaco  
Base 1013 Matt ivory



## AVION

Una sedia morbida ed accogliente ma con un forte carattere.  
Qui nella versione in tessuto bouclé arricchito da fasce di cuoio tono su tono.

AVION  
pelle



Seduta Pelle effetto morbido 533 Caramello  
Sitting Soft leather smooth effect 533 Caramel  
Cuoio pieno fiore 04 Testa di moro  
Full grain hide leather 04 Dark brown  
Base 8019 Marrone opaco  
Base 8019 Matt brown



AVION

Avion nella versione pelle e cuoio.  
Forte e decisa è realizzabile in molteplici combinazioni di colore.



AVION  
pelle



Seduta Pelle effetto morbido 533 Caramello  
Sitting Soft leather smooth effect 533 Caramel  
Cuoio pieno fiore 04 Testa di moro  
Full grain hide leather 04 Dark brown  
Base 8019 Marrone opaco  
Base 8019 Matt brown



BONA  
design  
Andrea Pinori e  
Giorgio Balestri



Esterno Cuoio pieno fiore 01 Tabacco  
External Full grain hide leather 01 Tobacco  
Interno Pelle nabuk 1707 Becco d'anatra  
Internal Soft leather Nabuk 1707 Duck bill  
Paracolpi acciaio 465 ottone striato  
Steel bumpers 465 striped brass

BONA



Esterno Cuoio pieno fiore 01 Tabacco  
External Full grain hide leather 01 Tobacco  
Interno Pelle nabuk 1708 Cuoio  
Internal Soft leather nabuk 1708 Saddle

BONA

Poltrona lounge raffinata ed estremamente versatile:  
in soggiorno per accentuare un angolo conversazione,  
in camera o in sala di attesa.  
Lo schienale interno e la seduta sono imbottiti e rivestiti in pelle pregiata.  
La struttura è in multistrato di faggio ed è dotata di paracolpi in acciaio  
realizzabili in varie finiture.  
Struttura interamente rivestita in cuoio pieno fiore Fasem.



CAYMAN BAR BT  
design  
Archirivolto



## CAYMAN BAR BT

Sgabello ad altezza regolabile a gas. Base e schienale in acciaio.  
Seduta rivestita in cuoio.



Seduta Cuoio pieno fiore 18 Naturale  
Sitting Full grain hide leather 18 Natural  
Base 495 Bronzo opaco  
Base 495 Matt bronze

Seduta Cuoio pieno fiore 22 Avorio  
Sitting Full grain hide leather 22 Ivory  
Base 444 Nickel nero  
Base 444 Black nickel







CAYMAN BAR POLI BT

## CAYMAN BAR POLI BT

Sgabello ad altezza regolabile a gas. Base e schienale in acciaio.  
Seduta in policarbonato trasparente.



# CHARME

design  
Archirivolto

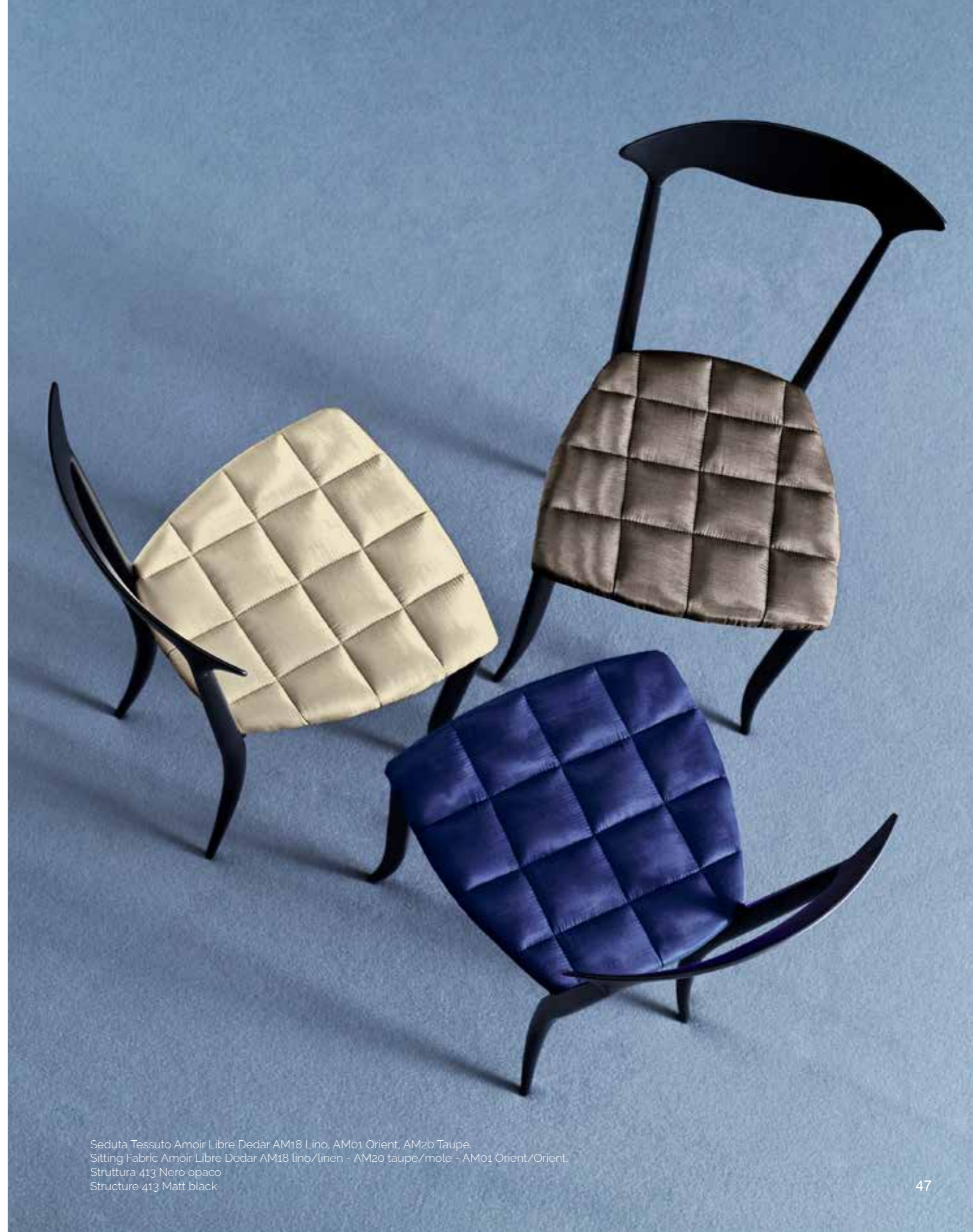

Seduta Tessuto Amoir Libre Dedar AM18 Lino, AM01 Orient, AM20 Taupe.  
Sitting Fabric Amoir Libre Dedar AM18 lino/linen - AM20 taupe/mole - AM01 Orient/Orient.  
Struttura 413 Nero opaco  
Structure 413 Matt black



CHARME

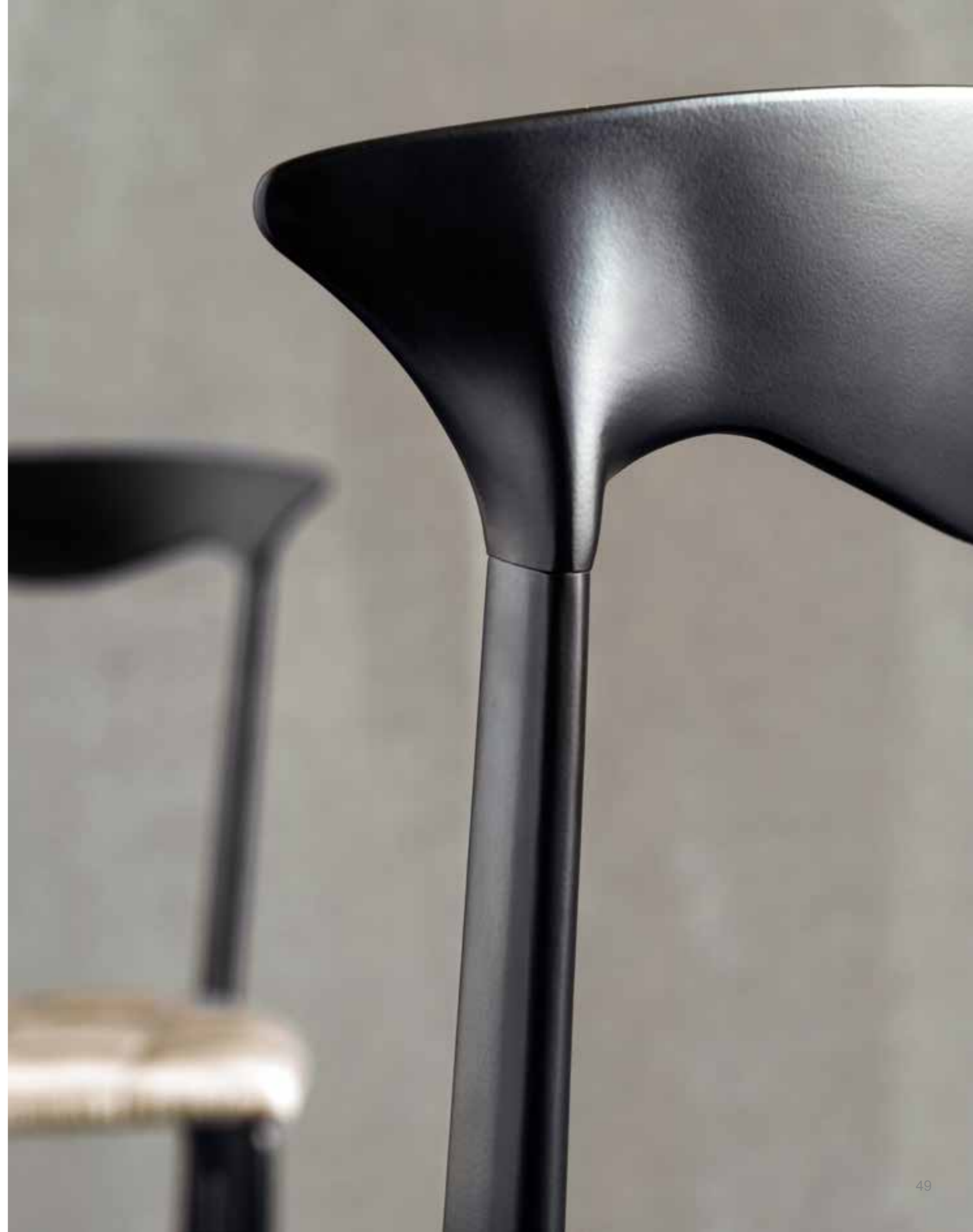

## CHARME



Seduta pelle effetto morbido 502 Nero  
Sitting Soft leather smooth effect 502 Black  
Struttura 413 Nero opaco  
Structure 413 Matt black

## CHARME

Charme, una sedia senza tempo.  
È esile ma robusta, facilmente abbinabile grazie al suo stile sobrio ed elegante.  
Realizzata in alluminio pressofuso  
può essere rivestita in pelle oppure in tessuto con lavorazione matelassé .



Seduta pelle effetto morbido 522 Avorio  
Sitting Soft leather smooth effect 522 Ivory  
Struttura 1013 Avorio opaco  
Structure 1013 Matt ivory

CROP  
design  
Ross Lovegrove

Versione con seduta bicolore.  
Esterno Cuoio pieno fiore 09 Bordeaux  
External Full grain hide leather 09 Bordeaux  
Interno Cuoio pieno fiore 03 Rosso bulgaro  
Internal Full grain hide leather 03 Bulgarian Red  
Base 495 Bronzo opaco  
Base 495 Matt bronze

## CROP

Sinuosa, solida e leggerissima.  
Ha una scocca curvata in multistrato di faggio interamente  
rivestita in cuoio pieno fiore.  
Base fissa in acciaio con piedini inclinabili.



Seduta Cuoio pieno fiore 01 Tabacco  
Sitting Full grain hide leather 01 Tobacco  
Base 1013 Avorio opaco  
Base 1013 Matt ivory

Seduta Cuoio pieno fiore 22 Avorio  
Sitting Full grain hide leather 22 Ivory  
Base 1013 Avorio opaco  
Base 1013 Matt ivory



ELECTA  
design  
Archirivolto



Esterno cuoio pieno fiore 06 Grigio  
External full grain hide leather 06 Grey  
Interno Pelle effetto morbido 506 Grigio  
Internal Soft leather smooth effect 506 Grey  
Base 470 Titanio  
Base 470 Titanium

Esterno cuoio pieno fiore lux 53 Petrolio  
External full grain hide leather lux 53 Petrol  
Interno pelle effetto morbido 692 Colbert  
Internal Soft leather smooth effect 692 Colbert  
Base 470 Titanio  
Base 470 Titanium





ELECTA BC

## ELECTA BC

Poltrona girevole con base a croce.  
Seduta e schienale in acciaio rivestiti in pelle e cuoio.  
Una poltrona ricca di dettagli e con una conformazione ergonomica della seduta e dello schienale che garantiscono un alto livello di comfort.



Esterno cuoio pieno fiore 09 Bordeaux  
External full grain hide leather 09 Bordeaux  
Interno Pelle nabuk 1034 Bordeaux  
Internal Soft leather nabuk 1034 Bordeaux  
Base 495 Bronzo opaco  
Base 495 Matt Bronze

ELECTA BC



## ELECTA TALL BC



Esterno Pelle 532 Camel  
External soft leather 532 Camel  
Interno Pelle nabuk 1708 Cuoio  
Internal Soft leather nabuk 1708 Saddle  
Base 470 Titano  
Base 470 Titanium

## ELECTA TALL BC

Nella versione in pelle con schienale alto  
questa sofisticata poltrona si adatta a qualsiasi tipo di ambiente  
donando allo spazio un tocco di eleganza.





ELECTA BAR BT



Esterno Cuoio pieno fiore 06 Grigio  
External Full grain hide leather 06 Grey  
Interno Pelle effetto morbido 532 Cammello  
Internal Soft leather smooth effect 532 Camel  
Base 444 Nickel nero  
Base 444 Black nickel

## ELECTA BAR BT

Sgabello con struttura girevole e regolabile in altezza. Leva rivestita in cuoio.  
Ha una comoda seduta imbottita.  
Articolo di grande effetto scenico è realizzabile in pelle e cuoio tono su tono  
o con decisi contrasti di colore.



Esterno cuoio pieno fiore lux 51 Miele  
External full grain hide leather lux 51 Honey  
Interno Pelle effetto morbido 502 Nero  
Internal soft leather smooth effect 502 Black  
Base 4444 Nickel nero  
Base 444 Black nickel

## ELECTA LOUNGE

Poltrona Lounge con base girevole.

Un altro pezzo della serie Electa dal design fortemente caratterizzato dalla struttura in cuoio curvato arricchito da un'inserito decorativo e da schienale e seduta imbottiti e rivestiti in morbida pelle.

Completano la collezione  
Electa coffee table ed Electa side table.



Esterno Cuoio pieno fiore 18 Naturale  
External Full grain hide leather 18 Natural  
Interno Pelle effetto morbido 507 Blu  
Internal Soft leather smooth effect 507 Blue  
Base 413 Nero opaco  
Base 413 Matt black

ELECTA LOUNGE



Esterno Cuoio pieno fiore 07 Blu scuro  
External Full grain hide leather 07 Dark Blue  
Interno Pelle effetto morbido 507 Blu  
Internal Soft leather smooth effect 507 Blue  
Base 413 Nero opaco  
Base 413 Matt black

## ELECTA RELAX

Una poltrona timeless con braccioli che può essere corredata dal poggiatesta coordinato.  
La seduta poggia su una base in acciaio disponibile in varie finiture.  
Morbida ed accogliente è ideale per veri momenti di relax.



Esterno cuoio pieno fiore 01 Tabacco  
External full grain hide leather 01 Tobacco  
Interno Pelle effetto morbido 679 Miele  
Internal soft leather smooth effect 679 Honey  
Base 465 Ottone striato  
Base 465 Striped brass



## ELECTA RELAX CON POUF

La poltrona abbinata al suo poggiatesta coordinato crea una confortevole chaise longue in cui abbandonarsi per momenti di grande relax.



# FETTUCCINI

design  
Vladimir Kagan





FETTUCCINI P

Cuoio pieno fiore 18 Naturale  
Full grain hide leather 18 Natural  
Base 400 Cromo lucido  
Base 400 Shiny chrome

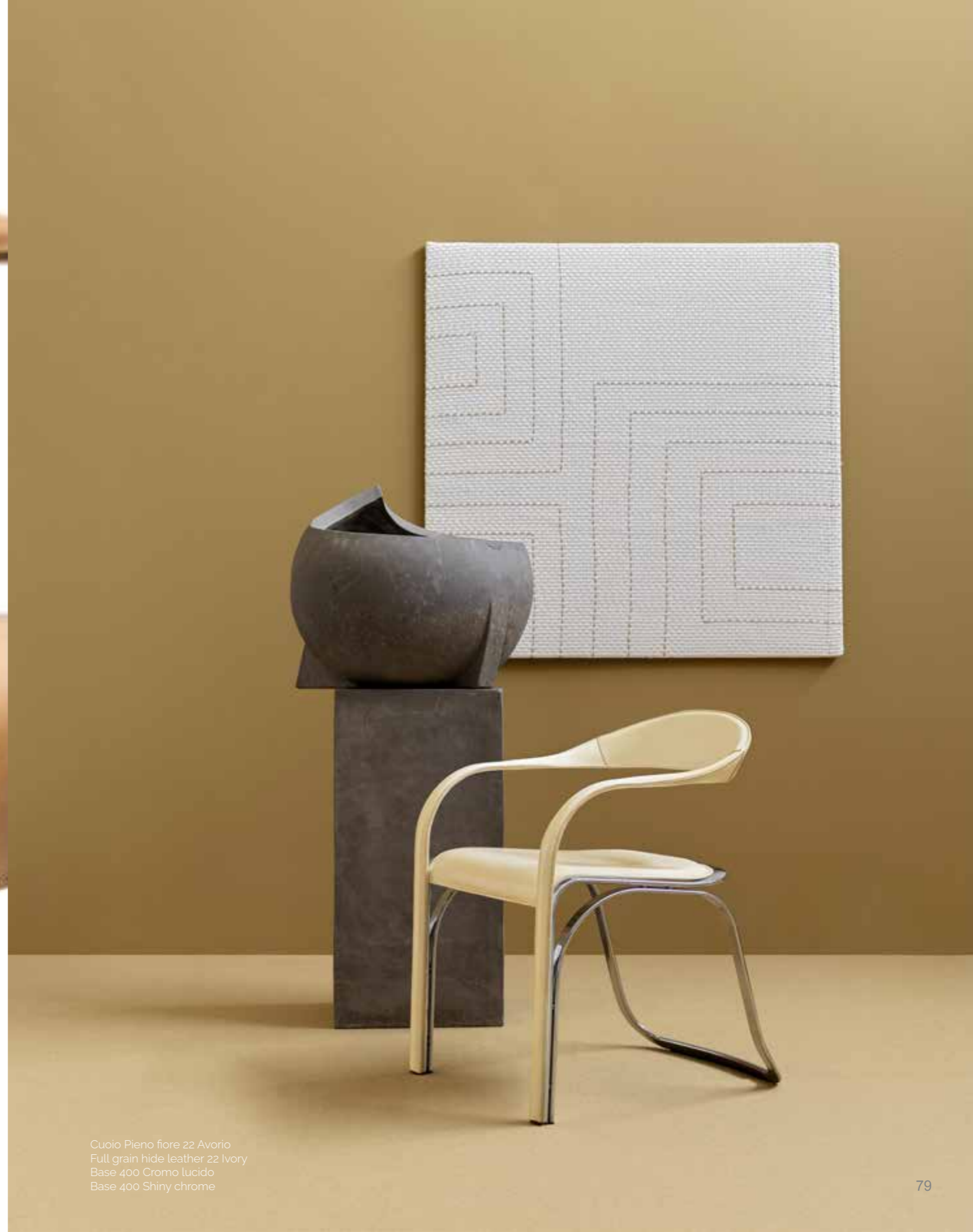

Cuoio Pieno fiore 22 Avorio  
Full grain hide leather 22 Ivory  
Base 400 Cromo lucido  
Base 400 Shiny chrome



FETTUCCINI P



FETTUCCINI P

Un pezzo iconico dell'azienda. Quasi una scultura.  
Impossibile non riuscire ad apprezzarne il valore  
e la complessità nella realizzazione.



FETTUCCINI W  
design  
Vladimir Kagan



Cuoio Pieno fiore 30 Verde inglese  
Full grain hide leather 30 English green  
Base 444 Nickel nero  
Base 444 Black nickel



FETTUCCINI W



FETTUCCINI W

Poltrona con schienale flessibile a doppia fascia.  
Unica e con forte personalità questa poltrona  
può caratterizzare una zona living o uno spazio comune.

Cuoio Pieno fiore 06 Grigio  
Full grain hide leather 06 Grey  
Base 444 Nickel nero  
Base 444 Black nickel

FIORILE  
design  
Archirivolto



## FIORILE BT



Cuoio pieno fiore 18 Naturale  
Full grain hide leather 18 Natural  
Base 444 Nickel nero  
Base 444 Black nickel

## FIORILE BT

Fiorile si sviluppa su una solida base girevole in acciaio con seduta completamente rivestita in pregiato cuoio. Come per tutti i prodotti Fasem, le lavorazioni sono fatte rigorosamente a mano da esperti artigiani.

FIORILE BAR BT



FIORILE BAR BT

Sgabello girevole con base in acciaio ad altezza regolabile a gas.  
Scocca in hirek® leggermente imbottita e completamente rivestita  
in cuoio pieno fiore o pelle.  
Leva rivestita in cuoio pieno fiore o pelle .



Cuoio Pieno fiore 30 Verde inglese  
Full grain hide leather 30 English green  
Base 444 Nickel nero  
Base 444 Black nickel

Cuoio Pieno fiore 07 Blu scuro  
Full grain hide leather 07 Dark blue  
Base 444 Nickel nero  
base 444 Black nickel

# FIORILE PLISSÉ

design  
Archirivolto



## FIORILE PLISSÉ BC

Una lavorazione da alta pelletteria per creare questo prodotto dove cuoio e pelle si uniscono dando vita ad un'accogliente seduta di sicuro impatto visivo.



Esterno Cuoio pieno fiore 04 Testa di moro  
External Full grain hide leather 04 Dark brown  
Interno Pelle nabuk 1707 Becco d'anatra plissé  
Internal Soft leather nabuck 1707 Duck bill plissé  
Base 470 Titanio  
base 470 Titanium





## FIORILE BAR PLISSÉ BT



## FIORILE BAR PLISSÉ BT

Appartengono alla famiglia dei Fiorile plissé anche questi sgabelli ad altezza regolabile.  
Pensati per progettare gli interni con stile e personalità.

## FIORILE BAR PLISSÉ BT



Cuoio Pieno fiore 22 Avorio  
Full grain hide leather 22 Ivory  
Interno Pelle effetto morbido 619 Giallo mostarda plissé  
Internal Soft leather smooth effect 619 Mustard yellow plissé  
Base 495 Bronzo opaco  
Base 495 Matt Bronze

Cuoio Pieno fiore 09 Bordeaux  
Full grain hide leather 09 Bordeaux  
Interno Pelle effetto morbido 547 Polvere plissé  
Internal Soft leather smooth effect 547 Dust plissé  
Base 495 Bronzo opaco  
Base 495 Matt Bronze



## FIORILE PLISSÉ BT



## FIORILE PLISSÉ BT

La creatività applicata al cuoio e alla pelle danno vita ad un'inedita interpretazione di seduta.

Esterno Cuoio pieno fiore 02 Nero  
External Full grain hide leather 02 Black  
Interno Pelle effetto morbido 502 Nero plissé  
Internal soft leather smooth effect 502 Black plissé  
Base 460 Ottone opaco  
Base 460 Matt brass

## FIORILE LOUNGE PLISSÉ BC

Esterno Cuoio pieno fiore 07 Blu scuro  
External Full grain hide leather 07 Dark blue  
Interno Pelle effetto morbido 522 Avorio  
Internal soft leather smooth effect 522 Ivory  
Base 495 Bronzo opaco  
Base 495 Matt bronze



## FIORILE LOUNGE PLISSÉ BC



Esterno Cuoio pieno fiore lux 54 Cioccolato  
External Full grain hide leather lux 54 Chocolate  
Interno Pelle effetto morbido 535 mogano plissé  
Internal soft leather smooth effect 535 Mahogany plissé  
Base 400 Cromo lucido  
Base 400 Shiny chrome

## FIORILE LOUNGE PLISSÉ BC

### POLTRONA LOUNGE

Struttura girevole ad altezza fissa in acciaio.  
Base a croce rivestita con trattamento verniciatura a polvere  
o trattamento galvanico o con doppio trattamento a polvere e liquido.  
Scocca in lamiera di acciaio leggermente imbottita e rivestita  
internamente in pelle plissettata ed  
esternamente in cuoio pieno fiore o pelle.

### LOUNGE ARMCHAIR

*Swivel steel structure with fixed height cross base.  
Coated with powder treatment or galvanic treatment or with double powder and liquid treatment  
steel shell slightly padded and covered  
inside with pleated soft leather,  
outside with full grain hide leather or soft leather.*



LOLA  
design  
Archirivolto



Seduta pelle Nabuk  
Sitting Soft leather Nabuk  
Cuoio pieno fiore 01 Tabacco  
Full grain hide leather 01 Tobacco  
Seduta in pelle Nabuk 1708 Cuoio  
Sitting Soft leather Nabuk 1708 Saddle  
Base 495 Bronzo opaco  
Base 495 Matt Bronze



LOLA



LOLA

Soluzioni inedite, finiture e materiali ricercati per il design di questa sedia con schienale in cuoio lavorato a griglia e seduta circolare in Nabuk.



Cuoio pieno fiore 06 Grigio  
Full grain hide leather 06 Grey  
Seduta pelle nabuk 1012 Antracite  
Sitting Soft leather nabuk 1012 Anthracite grey  
Base 478 Peltro  
Base 478 Pewter



## LOLA

### SEDIA DA PRANZO

Struttura in acciaio fissa 4 gambe.  
Rivestita con trattamento verniciatura a polvere o trattamento galvanico  
o con doppio trattamento a polvere e liquido.  
Seduta in multistrato di faggio imbottita e rivestita di pelle Nabuk.  
Schienale in intreccio di cuoio pieno fiore.

### DINING CHAIR

*Fixed steel structure 4 legs.  
Coated with powder treatment or galvanic treatment  
or with double powder and liquid treatment.  
Seat in beech plywood padded and covered with soft leather.  
Backrest made of full grain hide leather weave.*



LYS P  
design  
Marc Sadler



Cuoio pieno fiore 31 Verde salvia  
Full grain hide leather 31 Sage green



LYS P



LYS P

Per ambienti che fanno della leggerezza la loro forza. Una prestigiosa seduta dal design delicato nel segno di un'eleganza senza tempo. Il cuoio veste questa poltrona come un abito. Le cuciture artigianali ne impreziosiscono i braccioli.



LYS W



Cuoio pieno fiore 01 Tabacco  
Full grain hide leather 01 Tobacco

LYS W



Cuoio pieno fiore 20 Arancio  
Full grain hide leather 20 Orange



LYS W

POLTRONA LOUNGE  
con struttura in acciaio fissa a 4 gambe.  
Completamente rivestita in cuoio pieno fiore o pelle.  
Cuciture a contrasto.

*LOUNGE ARMCHAIR  
Fixed steel structure 4 legs.  
Fully covered with full grain hide leather or soft leather.  
Contrast stitching.*

# NET W

design  
Giancarlo Vegni



Cuoio pieno fiore 01 Tabacco  
Full grain hide leather 01 Tobacco  
Base 495 Bronzo opaco  
Base 495 Matt Bronze

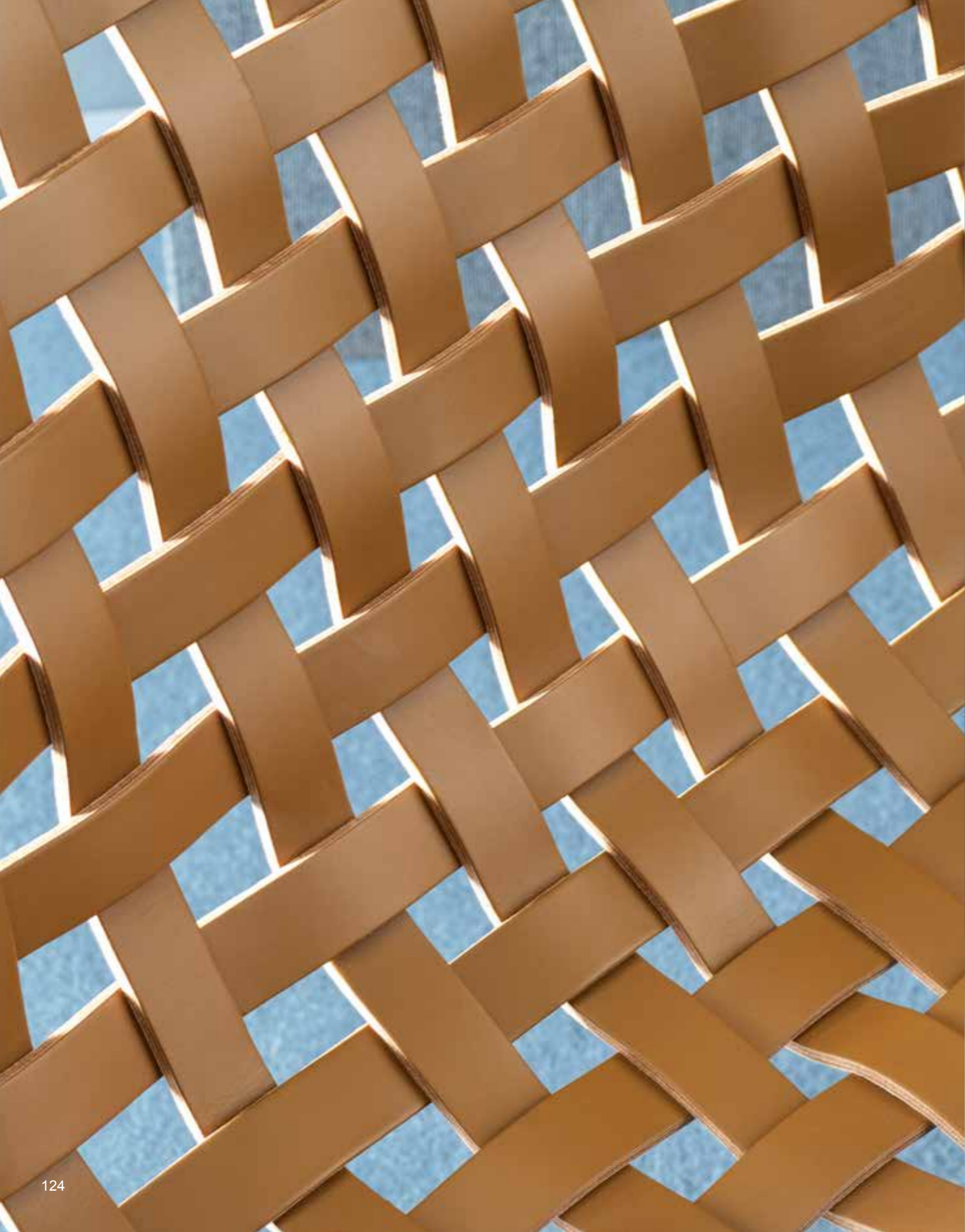

NET W



Cuoio pieno fiore 31 Verde salvia  
Full grain hide leather 31 Sage green  
Base Titanio/Titanium 470

NET W

Accostamenti cromatici, studio delle forme, degli effetti della luce sulla rete di cuoio intrecciato ed il lavoro di mani sapienti rendono Net W una poltrona potente ma leggera.



O'MIES  
design  
Giancarlo Vegni



Cuoio pieno fiore 32 Grigio argilla  
Full grain hide leather 32 Clay grey  
Base Nickel nero/Black nickel 444

O'MIES



O'MIES



Cuoio pieno fiore 51 Miele  
Full grain hide leather 51 Honey  
Base 444 Nickel nero  
Base 444 Black nickel

O'MIES

Ha tutte le qualità per essere la vera protagonista dello spazio relax.  
Lo spessore del cuoio a taglio vivo si sposa elegantemente con le linee curvate  
della struttura in acciaio.

L'ampia e allo stesso tempo leggera seduta in cuoio,  
disponibile in diverse tonalità,  
è cucita su una struttura metallica solida  
ma allo stesso tempo elastica così da rendere piacevole l'accomodarsi.

P40  
design  
Giancarlo Vegni e  
Gianfranco Gualtierotti

Cuoio pieno fiore 01 Tabacco  
Full grain hide leather 01 Tobacco  
Base 413 Nero opaco  
Base 413 Matt black

P40



P40

Poltrona con schienale avvolgente. Un design contemporaneo per una seduta Timeless.  
Ideale per ogni tipo di impiego



Cuoio pieno fiore 02 Nero  
Full grain hide leather 02 Black  
Base Cromo Lucido/Shiny chrome 400

P90  
design  
Giancarlo Piretti



Cuoio pieno fiore 51 Miele  
Full grain hide leather 51 Honey

Cuoio pieno fiore 31 Verde salvia  
Full grain hide leather 31 Sage green



## Pgo

Una struttura d'acciaio vestita da un'abito in cuoio fermato inferiormente da fibbie e cinturini.

Il rivestimento si appoggia alla struttura pur rimanendo libero di adeguarsi alle forme con l'uso.

Pgo è una poltroncina comoda e versatile, un classico contemporaneo per chi non vuole rinunciare al comfort senza perdere una rigorosa eleganza.



## Pgo





P90



Cuoio pieno fiore 01 Tabacco  
Full grain hide leather 01 Tobacco



RELAIX  
design  
Studio Datta-Mosca



RELAIX P



RELAIX P

Poltroncina sottile e discreta, un'eleganza non comune, fatta di dettagli ne che sottolineano l'anima artigianale. Gambe, seduta, schienale e braccioli sono rivestiti in pregiato cuoio pieno fiore.



Cuoio pieno fiore 01 Tabacco  
Full grain hide leather 01 Tobacco  
Base 8019 Marrone opaco  
Base 8019 Matt brown

Cuoio pieno fiore 32 Grigio argilla  
Full grain hide leather 32 Clay grey  
Base 413 Nero opaco  
Base 413 Matt black

RELAIX S



Cuoio pieno fiore 22 Avorio  
Full grain hide leather 22 Ivory  
Base 1013 Avorio opaco  
Base 1013 Matt Ivory



## RELAIX BAR



Cuoio pieno fiore 02 Nero  
Full grain hide leather 02 Black  
Base 413 Nero opaco  
Base 413 Matt black

## RELAIX BAR

Sgabello con struttura rivestita in cuoio pieno fiore.  
La caratteristica lavorazione dello schienale come elemento distintivo di un modello  
dallo stile rigoroso e rassicurante.



# REST

design  
Patrick Norguette



## REST

Forme generose per una seduta lounge soft touch.  
Un incontro inaspettato fra pelle e tessuto bouclé Dedar che rinnova i canoni stilistici di Fasem.  
Per chi è alla ricerca di un modello in grado di regalare all'ambiente accenti sofisticati.



Esterno Pelle 522 Avorio  
External Soft leather 522 Ivory  
Interno Tessuto Atlas Dedar AT 01 Avorio  
Internal Fabric Dedar Atlas AT 01 Ivory  
Base 460 Ottone opaco  
Base 460 Matt brass



REST



Pelle effetto morbido 502 Nero  
Soft leather smooth effect 502 Black  
Base 444 Nichel nero  
Base 444 Black nickel

REST

Sedia lounge girevole ad altezza fissa su base in acciaio a croce.  
Seduta e schienale in faggio curvato imbottito e rivestito in pelle.



RIO  
design  
Oscar Niemeyer

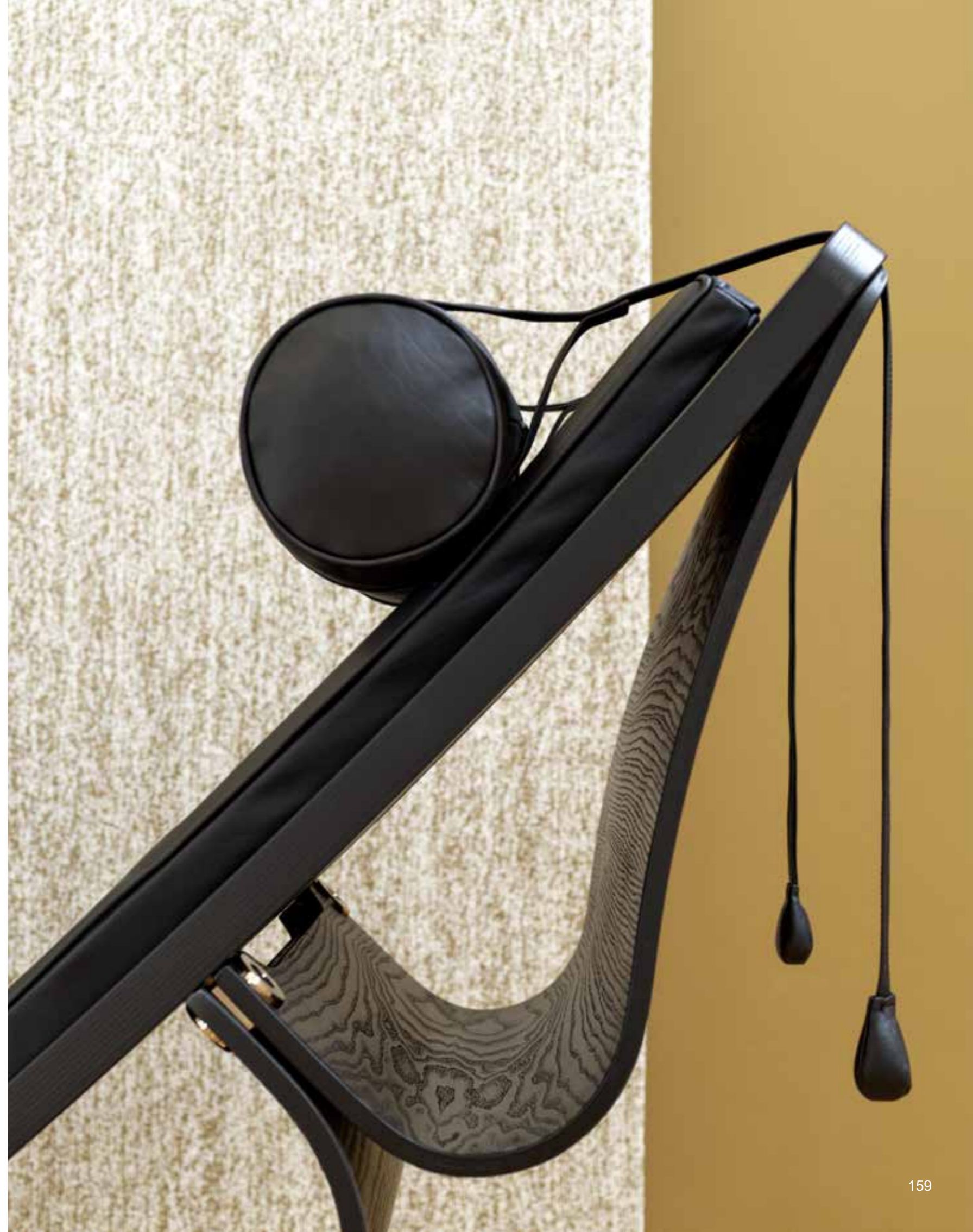



RIO

RIO

Uno straordinario pezzo di design nato dal genio di Oscar Niemeyer.

Struttura basculante in frassino verniciato a poro aperto  
unicamente nel colore nero.

Cuscino e poggiatesta imbottiti e rivestiti in pelle effetto morbido nera.  
Fasem ha il privilegio e l'onore di produrre la versione in pelle  
della chaise longue RIO  
disegnata dal Maestro nel 1978.



RIO



Pelle effetto morbido 502 Nero  
Soft leather smooth effect 502 Black  
Struttura Frassino tinto nero a poro aperto 402  
Structure Black stained ash with open pore 402



S44  
design  
Giancarlo Vegni e  
Gianfranco Gualtierotti



Cuoio pieno fiore 01 Tabacco  
Full grain hide leather 01 Tobacco  
Base 495 Bronzo opaco  
Base 495 Matt bronze

## S44

Sedia con schienale alto.

Una seduta dalla linea essenziale disegnata dalla struttura in metallo  
che accoglie la sottile ma imbottita seduta in cuoio.  
Schienale in acciaio, anch'esso leggermente imbottito e rivestito in cuoio.



Cuoio pieno fiore 30 Verde Inglese  
Full grain hide leather 30 English Green  
Pelle effetto morbido 519 Verde  
Soft leather smooth effect 519 Green  
Base 413 Nero opaco  
Base 413 Matt black

Sg1  
design  
Giancarlo Piretti



Cuoio pieno fiore 18 Naturale  
Full grain hide leather 18 Natural



## S91

L'archetipo della sedia.  
Linee definite disegnano questa sedia dedicata a chi guarda all'essenza delle cose.

Un perfetto equilibrio fra materiali e volumi  
ma la sua vera vocazione sta nel comfort, nella solidità e nella grande qualità  
di tutti gli elementi che la compongono.



S92  
design  
Giancarlo Pogni





## S92

Sembra sospesa nel tempo.  
La sedia total-leather dove il cuoio mostra tutta la sua matericità  
insieme ad un'eleganza atemporale.  
Seduta generosa e gambe ben piazzate a terra trasmettono la solidità e la concretezza di  
un prodotto fatto per durare.





## CUOIO TOSCANO

Naturale, riciclabile e sostenibile. Materia prima che dà vita a prodotti di assoluta qualità, con tecniche di lavorazione che si tramandano da secoli. L'attività di concia in Toscana era già conosciuta all'epoca degli Etruschi, che popolavano le zone costiere della regione ma ebbe grande sviluppo nel Medioevo.

La concia vegetale, prima concia vera e propria, quella che per più tempo ha accompagnato la civiltà, è quella che ancora oggi è riconosciuta come la più tradizionale.

È riconoscibile, l'unica capace di impartire al cuoio proprietà inconfondibili, la più vicina alla condizione di natura, la più idonea a coniugare moda e tradizione, versatilità d'impiego e unicità del prodotto.

Il cuoio conciato al vegetale con tannino, principio attivo concentrato in numerosi tipi di alberi e piante, ha caratteristiche uniche: matura, si modifica, cambia leggermente il suo colore, sopporta l'uso intenso ed emana il suo tipico profumo.

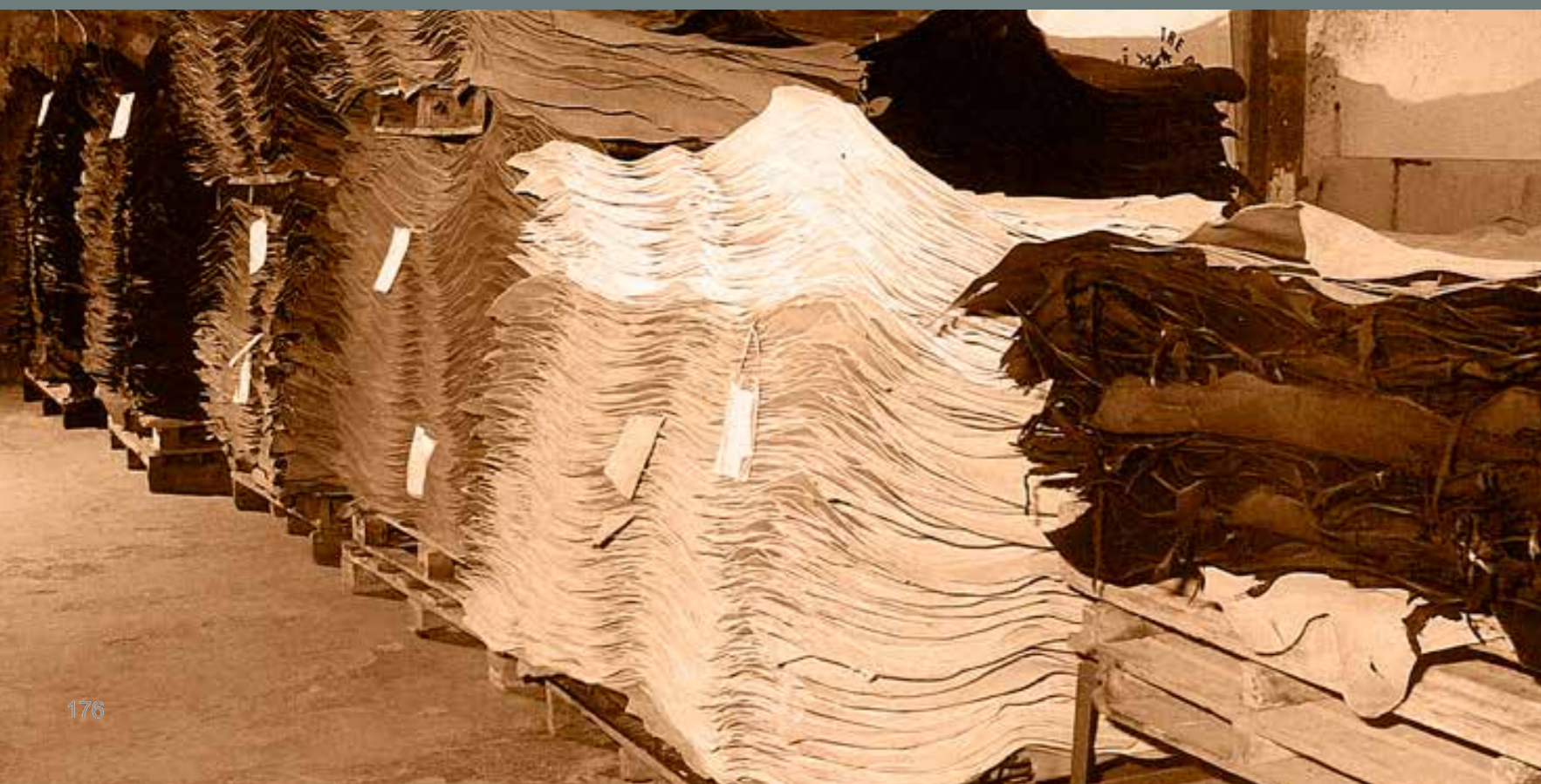

## CUOIO NON COLORATO 18

Un materiale a cui, tramite la concia al vegetale, viene conferita la particolare caratteristica di modificarsi nel tempo. I prodotti realizzati con il cuoio naturale non colorato non invecchiano, cambiano semplicemente look.

La luce naturale e l'uso personalizzano il prodotto rendendolo ancora più esclusivo ed affascinante attraverso una meravigliosa patina.



## TAVOLI E COMPLEMENTI

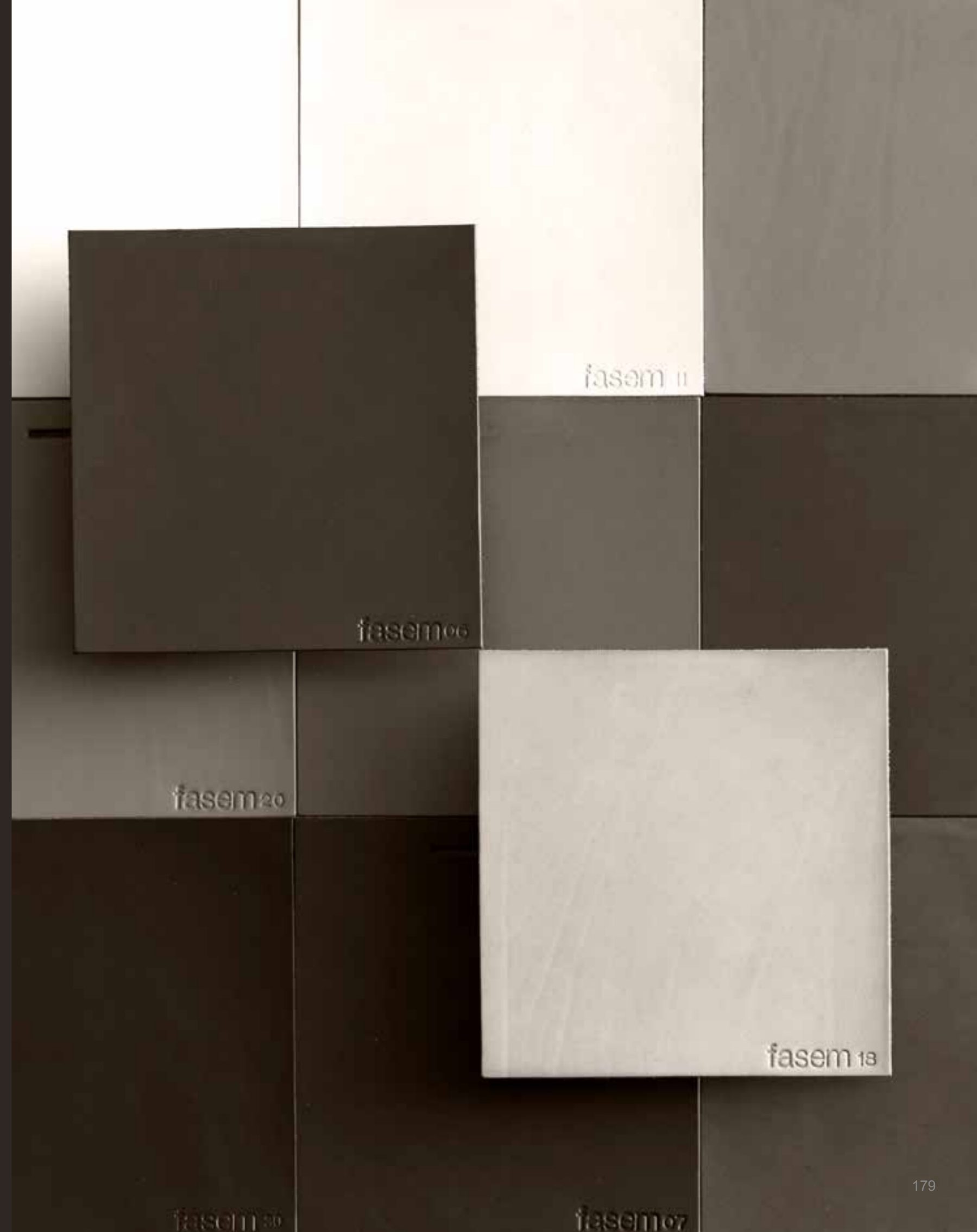

ADELE  
design  
Archirivolto



ADELE

Piano 840 Granito spazzolato nero opaco  
Top 840 Matt black flamed granite

Struttura Titanio 470  
Structure Titanium 470





## ADELE C

Materiali potenti come l'acciaio ed il granito si uniscono al cuoio per dare vita ad un tavolo dal design deciso. Una composizione scultorea composta da elementi metallici dai diversi spessori che con il piano creano uno scenografico effetto.



Piano 840 granito spazzolato nero opaco  
Top 840 Matt black brushed granite  
Struttura Titanio 470  
Structure Titanium 470  
Inserti Cuoio pieno fiore 18 Naturale  
Inserts Full grain hide leather 18 Natural

# ALIANTE

design  
Giancarlo Vegni



Struttura legno 404 Rovere sbiancato  
Wood structure 404 Light shade oak  
Pelle nabuk 1708 Cuoio  
Soft leather nabuk 1708 Saddle  
Cornice 495 Bronzo opaco  
Frame 495 Matt Bronze

ALIANTE



ALIANTE

Linee pure ed equilibri di forma per questo mobile contenitore in legno con ante rivestite in nabuk e incorniciate da un prezioso bordo metallico, nella variante materica del bronzo, che ne segue il perimetro. Elegante e versatile per creare inediti accostamenti.



# ANTIMO

design  
Andrea Pinori e  
Giorgio Balestri



Cuoio pieno fiore 04 Testa di moro  
Full grain hide leather 04 Dark brown  
Dettagli 444 Nichel nero  
Details 444 Black nickel  
Piano 204 Cristallo bronzato  
Top 204 Bronzed glass



ANTIMO  
quadrato

ANTIMO  
quadrato

Materiali pregiati e complesse lavorazioni artigianali  
per un lussuoso tavolo quadrato con angoli arrotondati.  
La struttura in acciaio curvato è rivestita in cuoio pieno fiore.



Cuoio pieno fiore 09 Bordeaux  
Full grain hide leather 09 Bordeaux  
Dettagli 444 Nichel nero  
Details 444 Black nickel  
Piano 204 Cristallo bronzato  
Top 204 Bronzed glass

## ANTIMO rotondo

Cuoio pieno fiore 04 Testa di moro  
Full grain hide leather 04 Dark brown  
Dettagli 444 Nichel nero  
Details 444 Black nickel  
Piano 204 Cristallo bronzato  
Top 204 Bronzed glass



## ANTIMO rotondo

Cuoio pieno fiore 06 Grigio  
Full grain hide leather 06 Grey  
Dettagli 444 Nichel nero  
Details 444 Black nickel  
Piano 203 Cristallo fumé  
Top 204 Smoked glass



## ANTIMO rotondo

Grande carattere e spessori importanti esaltano la flessibilità del cuoio,  
materia della tradizione italiana,  
che riveste questo tavolo.  
I dettagli in metallo giocano un ruolo fondamentale.  
Elementi sofisticati che uniscono forma e funzione.

# CRAB

design  
Giancarlo Vegni



Struttura 1013 Avorio opaco  
Structure 1013 Matt ivory  
Piano 830 Travertino chiaro classico  
Top 830 Classic light travertine

CRAB

bjxbknxmjnxm mxkmmxmmzL,zp  
lxnskjcxjkcncxkcnkxn



CRAB



Struttura 478 Peltro  
Structure 478 Pewter  
Piano 810 Marmo bianco arabescato  
Top 810 White arabescato marble



## CRAB

bjxbknxmjnxmxxkmmxmmz,zp  
lxnskjcjkcnxkcnkxn



## ELECTA COFFEE TABLE

design  
Archirivolto

Geometria semplice e materiali importanti rendono questo tavolo facilmente abbinabile a qualsiasi stile. La grande possibilità di combinazioni lo cambiano d'abito per soddisfare ogni esigenza cromatica.



Cuoio pieno fiore 09 Bordeaux  
Full grain hide leather 09 Bordeaux  
Piano 820 Marmo Emperador  
Top 820 Emperador marble

## ELECTA SIDE TABLE

design  
Archirivolto

Completa la grande collezione il side table. In abbinamento con il coffee table o usato singolarmente gioca un ruolo importante nella zona living.



Cuoio pieno fiore 18 Naturale  
Full grain hide leather 18 Natural  
Piano 820 Marmo Emperador  
Top 820 Emperador marble



FLAVIO  
design  
Archirivolto



FLAVIO



Base cuoio pieno fiore 06 Grigio / 23 Tortora  
Base Full grain hide leather 06 Grey / 23 Dove grey  
Inserti 478 Peltro  
Inserts 478 Pewter  
Piano 201 Cristallo trasparente  
Top 201 Transparent Glass

FLAVIO

Forme e colori che sembrano emergere dalla roccia.  
Protagonisti sono il cristallo, capace di illuminare l'ambiente.  
L'acciaio decorato peltro che dà la forza.  
Il cuoio che dona calore.



LUX  
design  
Archirivolto



## LUX

Nasce dall'incontro fra natura e tecnologia.  
Il piano in pietra naturale abbinato ad una base in Ekotek®,  
risultato di una combinazione di resine altamente selezionate,  
cariche minerali naturali e pigmenti, genera un risultato inaspettato.  
Un tavolo dalle forme morbide e tocco vellutato.



Base 900 Ekotek®  
Base 900 Ekotek®  
Piano 603 Travertino classico  
Top 603 Classic travertine



MEZZÈ  
design  
Studio tecnico Fasem



## MEZZÈ

Colori, materiali e consistenze a contrasto giocano in questo set di tavoli funzionali e trasversali.



## MEZZÈ



Base 400 Cromo lucido  
Base 400 Shiny chrome  
Piano Cuoio pieno fiore 22 Avorio  
Top Full grain hide leather 22 Ivory

Base 413 Nero opaco  
Base 413 Matt Black  
Piano 800 Marmo bianco di Carrara  
Top 800 White Carrara marble

Base 413 Nero opaco  
Base 413 Matt Black  
Piano 820 Marmo Emperador  
Top 820 Emperador marble

# ROLLING

design  
Giancarlo Vegni



Base Cuoio pieno fiore 22 Avorio  
Base Full grain hide leather 22 Ivory  
Dettagli Acciaio Inox  
Details Stainless steel  
Piano 201 Cristallo trasparente  
Top 201 Transparent glass



Base Pelle nabuk 1708 Cuoio  
Base Soft leather nabuk 1708 Saddle  
Dettagli Acciaio inox  
Details Stainless steel  
Piano 201 Cristallo trasparente  
Top 201 Transparent glass

## ROLLING

Un racconto di forme architettoniche.  
Equilibrio fra rigore strutturale e materiali sensuali come il nabuk.  
Le bande impunturate avvolgono la base  
formando una spirale che ricorda la Colonna di Traiano.



Base Pelle nabuk 1012 Antracite  
Base Soft leather nabuk 1012 Anthracite grey  
Dettagli Acciaio inox  
Details Stainless steel  
Piano 201 Cristallo trasparente  
Top 201 Transparent glass



ROLLING 2B

Base Pelle nabuk 1708 Cuoio  
Base Soft leather nabuk 1708 Saddle  
Dettagli Acciaio inox  
Dettagli Stainless steel  
Piano 201 Cristallo trasparente  
Top 201 Transparent glass



# OFFICE



ABACO  
design  
Andrea Branzi

Elogio alla leggerezza.  
Uscita dalla matita di un'architetto che ha cambiato la storia del design italiano,  
Andrea Branzi,  
la scrivania Abaco è fatta di geometrie e trasparenze.  
Bella in casa come in ufficio si spoglia della tradizionale austerità.  
Un gioco di forme che sembrano sospese.



Cassetto e gambe Cuoio pieno fiore 23 Tortora  
Drawer and legs Full grain hide leather 23 Dove  
Gambe 444 Nickel nero  
Legs 444 Black nickel  
Piano 201 Cristallo trasparente  
Top 201 Transparent glass



Cassetto e gambe Cuoio pieno fiore 01 Tabacco  
Drawer and legs Full grain hide leather 01 Tobacco  
Gambe 444 Nickel nero  
Legs 444 Black nickel  
Piano 201 Cristallo trasparente  
Top 201 Transparent glass

ABACO E ALA  
design  
Andrea Branzi

Ala, cassettera da scrivania insieme al sottomano in cuoio completano la proposta.  
Completamente rivestita in cuoio con ruote invisibili pivotanti, Ala è un solido e funzionale contenitore.  
Il sottomano in cuoio, elegante accessorio da scrivania.



ABACO E ALA  
design  
Andrea Branzi

Equilibrio perfetto di forme, materiali e volumi. Un gioco fra pieni e vuoti dove cuoio, acciaio e vetro si combinano fra loro.



ADELE  
design  
Archirivolto

Il grande tavolo riunioni poggia su solida base in acciaio  
decorata da inserti irregolari in metallo.  
La lavorazione materica e opaca del piano in granito rinnova i canoni estetici  
di un materiale durissimo di origine vulcanica.



Piano 840 Granito spazzolato nero opaco  
Top 840 Matt black flamed granite  
Struttura 470 Titanio  
Structure 470 Titanium

ADELE  
design  
Archirivolto



ADELE C DESK  
design  
Archirivolto

bjxbknxmjnxmmxkmxmmxmmzl,zp  
lxnskjcxjkcncxkjcncxn



ADELE DESK  
design  
Archirivolto



AIRLUX BC  
design  
Noé Duchaufour Laurance

bjxbknxmjnxmxxkmmxmxmmzl,zp  
lxnskjcxjkcncxkcnkxn



ALIANTE  
design  
Giancarlo Vegni



ALIANTE

bjxbknxmjnxmxxkmmxmxmmzl,zp  
lxnskjcxjkcncxkcnkxn





ELECTA BG

ELECTA BC  
design  
Archirivolto

dxjhnbxnosijjhxbkjjxn  
cnmncxcnxcjxcnncxhxjnknknjn  
xjnjjhjhjnknjxjxnknkxmxoi  
xkmxkmlkxlkpkoklxlkxc



ELECTA TALL BC





## ELECTA TALL BG

bjxbknxmjnxmmxkmmxmmz,zp  
lxnskjcjkcnxkcnkxn





FLAVIO  
design  
Archirivolto

bjxbknxmjnxmmxkmxmmxmmzl,zp  
lxnskjcjkcncxkjcncxn



## FOSCA BIG ABF

design  
Andrea Pinori e  
Giorgio Balestri

bjxbknxmjnxmxxkmmxmmzl,zp



FOSCA



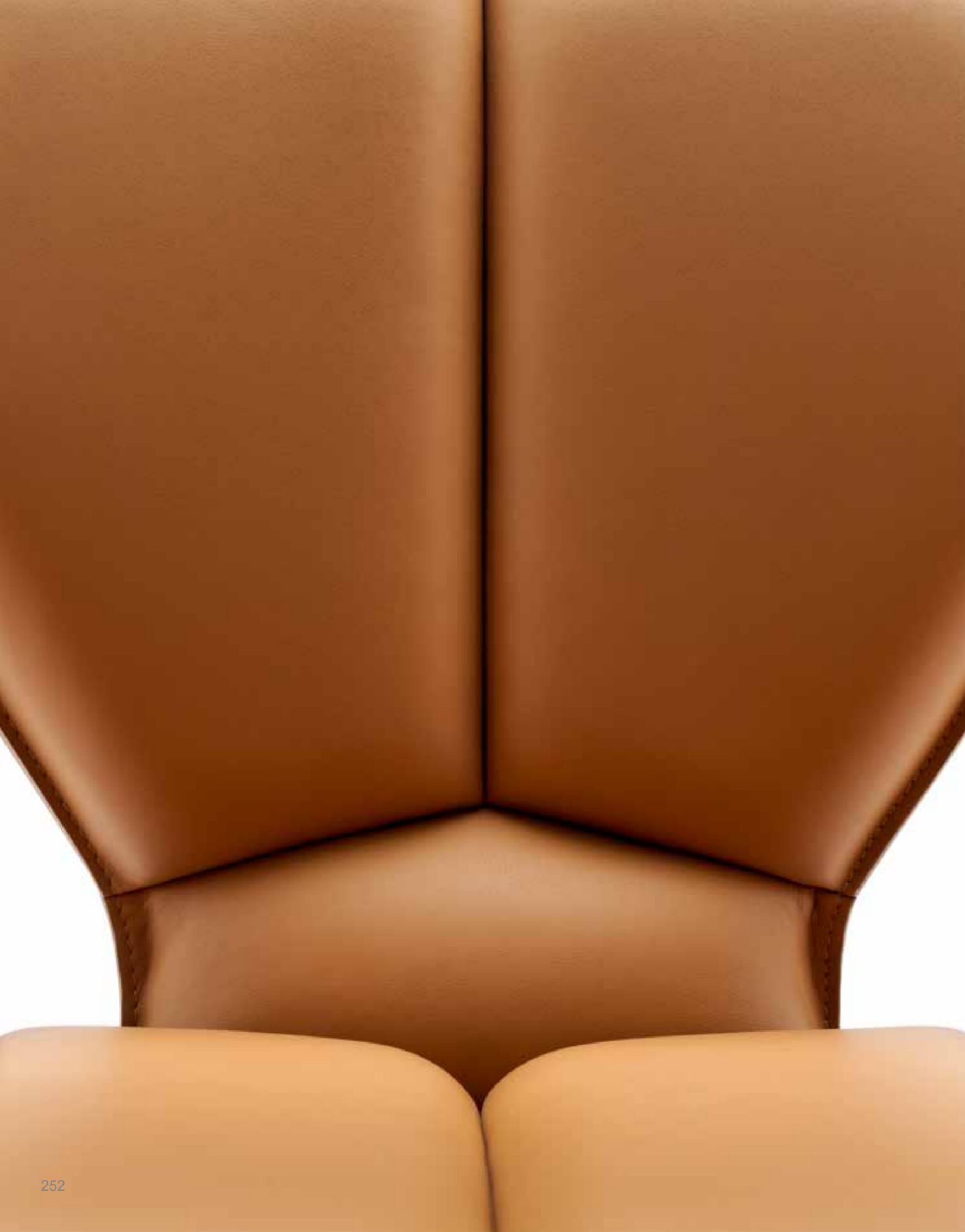

## FOSCA BIG ABW

dxjhnbnxnosijjhxzjhbxkjjxxn  
cnmnnxcnxcncxjcxenncnxhxjnxjnkjxnjxn  
xjnjjxhjhxjjnxnjxxxjnkxmxoi  
xkmxkmxlkjxlpokxlkxlkxc  
cnxcc xncmc mxx cx,c,xcxmlcmckmxmc  
cxmnmzxsaxjbxnxjkcsjaklmxz,mxxkzslkam xlzm  
xnknjknckjxclxmclxmcxkmlxcxlóc  
xnc lk m , mlkv kcmvxm cvxl,cxaàö  
clkncsahjdbasiudjsoidmdmxslkc



## FOSCA BIG TALL ABW

dxjhnbnxosijjhxzjhbxkjjxxn  
cnmnnxcnxcxcjxcnncnxhxjnxjnkjxnjxn  
xjnjjxhjhjxnjxnjxxjnkxmxoi  
xkmxkmxlkjxlkpokxlkxlkxc  
cnxcc xncmc mxx cx,c,xcxmlcmckmxmc  
cxmnmzxksaxjbxnxjkcsjaklmxz,mxxkzslkam xlzm  
xnknjknckjxclxmclxmcxkmlxcxlóc  
xnc lk m , mlkv kcmvxmcvkxl,cxaàò  
clkncahjdbsiudjsoidmdmxslkc





LUNA ABW  
design  
Martino Perego

dxjhnbnxosijjhxzjhbxkjjxxn  
cnmnnxcnxcncxcnncnxhxjnxjnkjxnjxn  
xjnjjxhjhjxnjxnjxxjnkxmxoi  
xkmxkmxlkjxlkpokxlkxlkxc

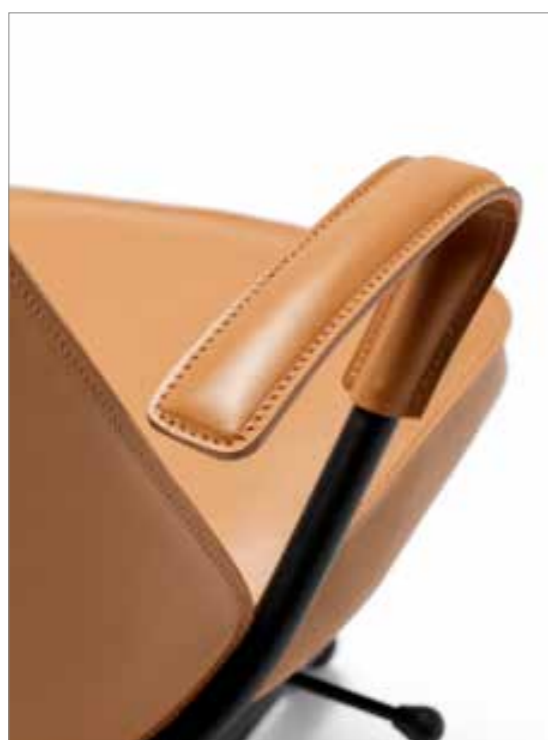

NORMAN D ABW  
design  
J.F. Smith

bjxbknxmjnxm mxk mxmmxmmzl,zp  
lxnskjcxjkcncxkjcncxn



P40  
design  
Giancarlo Vegni e  
Gianfranco Gualtierotti



Pgo



Pgo  
 design  
 Giancarlo Vegni

dxjhnbnxosijjhxzjhbxkjjxn  
 cnmrxnxcnxcxcxcnncnxhxjnxjnkjxnjn  
 xjnjjxhjhjxnjxnjxxjnkxmxoi  
 xkmxkmxlkjxlkpokxlkxlkxc  
 cnxcc xncmc mxx cx,c,xcxmlcmckmxmc  
 cxmnmzksaxibxnxikcsiaklmxz mxxkzslkam xlzm



RELAX ABW  
design  
Studio Datta-Mosca

dxjhnbnxosijjhxzjhbxkjjxn  
cnmnnxcnxcjxcnncnxhxjnxjnkjxnjn  
xjnjjxhjhjxnjxjxxjnkxmxoi  
xkmxkmlkxlkpkokxlkxlkxc  
cnxcc xncmc mxx cx,c,xcxmlcmckmxmc  
cxmnmzksaxjbnxjkcsjaklmxz,mxxkzslkam xlzm  
xnknjknckjxclxmclxmcxkmlxcxlòc  
xnc lk m , mlkv kcmvxcvkl,cxaàò  
clkncsahjdbasiudjsoidmdmxslkc





## RELAIX ABW

bjxbknxmjnxm mxk mxmmxmmzl,zp  
lxnskjcxjkc nxkjc nxn



ROLLING 2B  
design  
Giancarlo Vegni

bjxbknxmjnxmxxkmmxmxmmzl,zp  
lxnskjcxjkcncxkcnkxn



ROLLING DESK  
design  
Giancarlo Vegni





ROLLING DESK



ROLLING DESK

bjxbknxmjnxmxxkmmxmmz,zp  
lxnskjcxjcnxkcnkxn



TRESOR ABW  
design  
Claudio Dondoli





## TRESOR ABW

bjxbknxmjnxmxxkmmxmmz,zp  
lxnskjcjkcncxkcnkxn





HOME

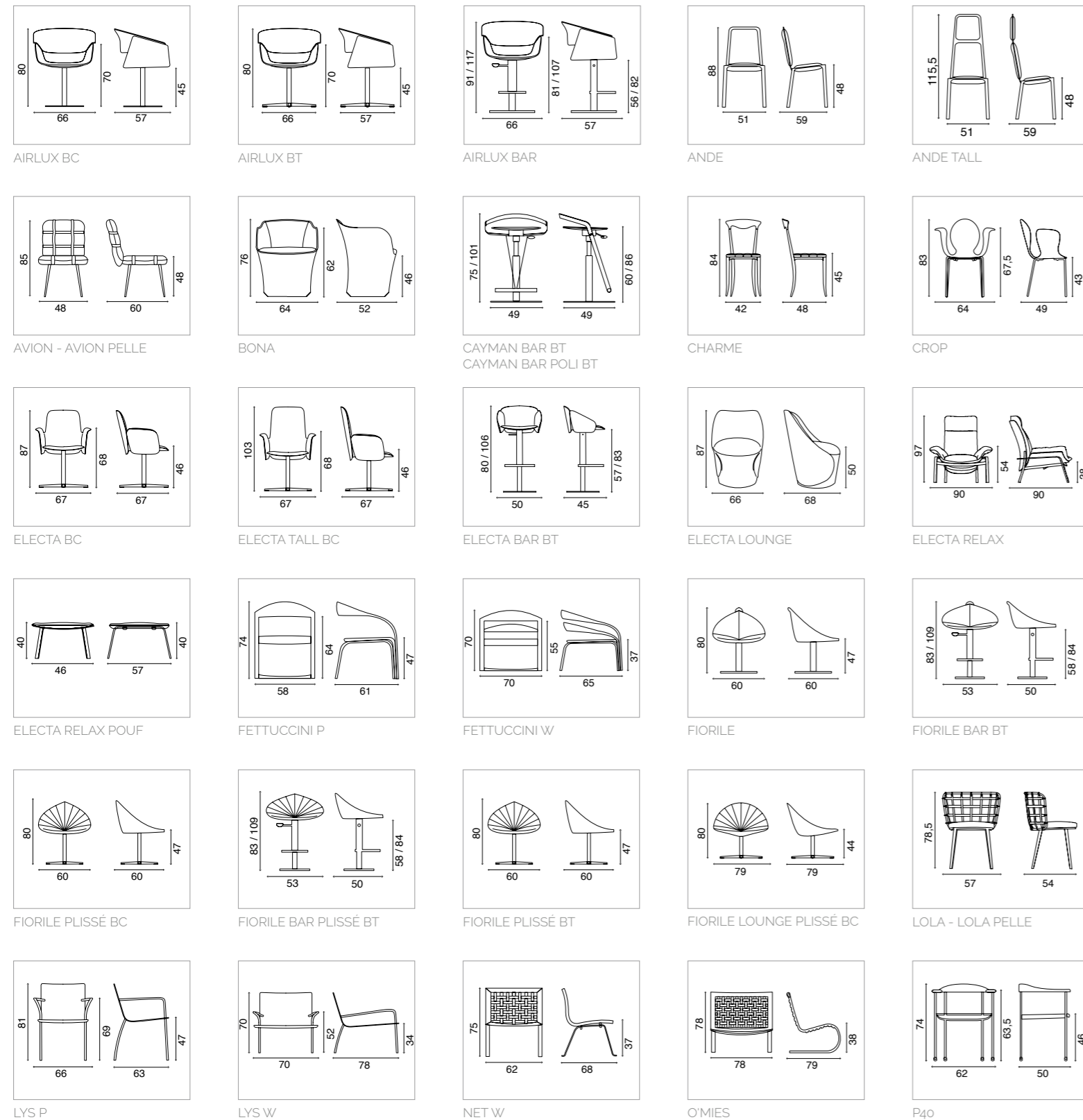

HOME

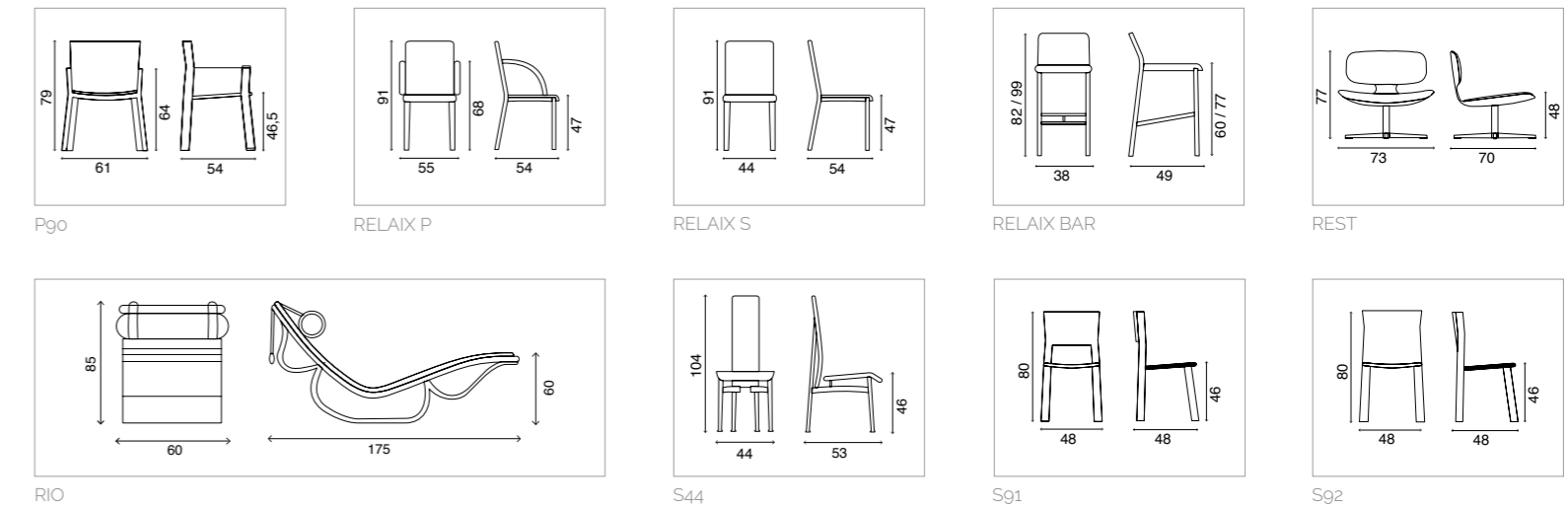

TAVOLI E COMPLEMENTI / TABLES AND COMPLEMENTS

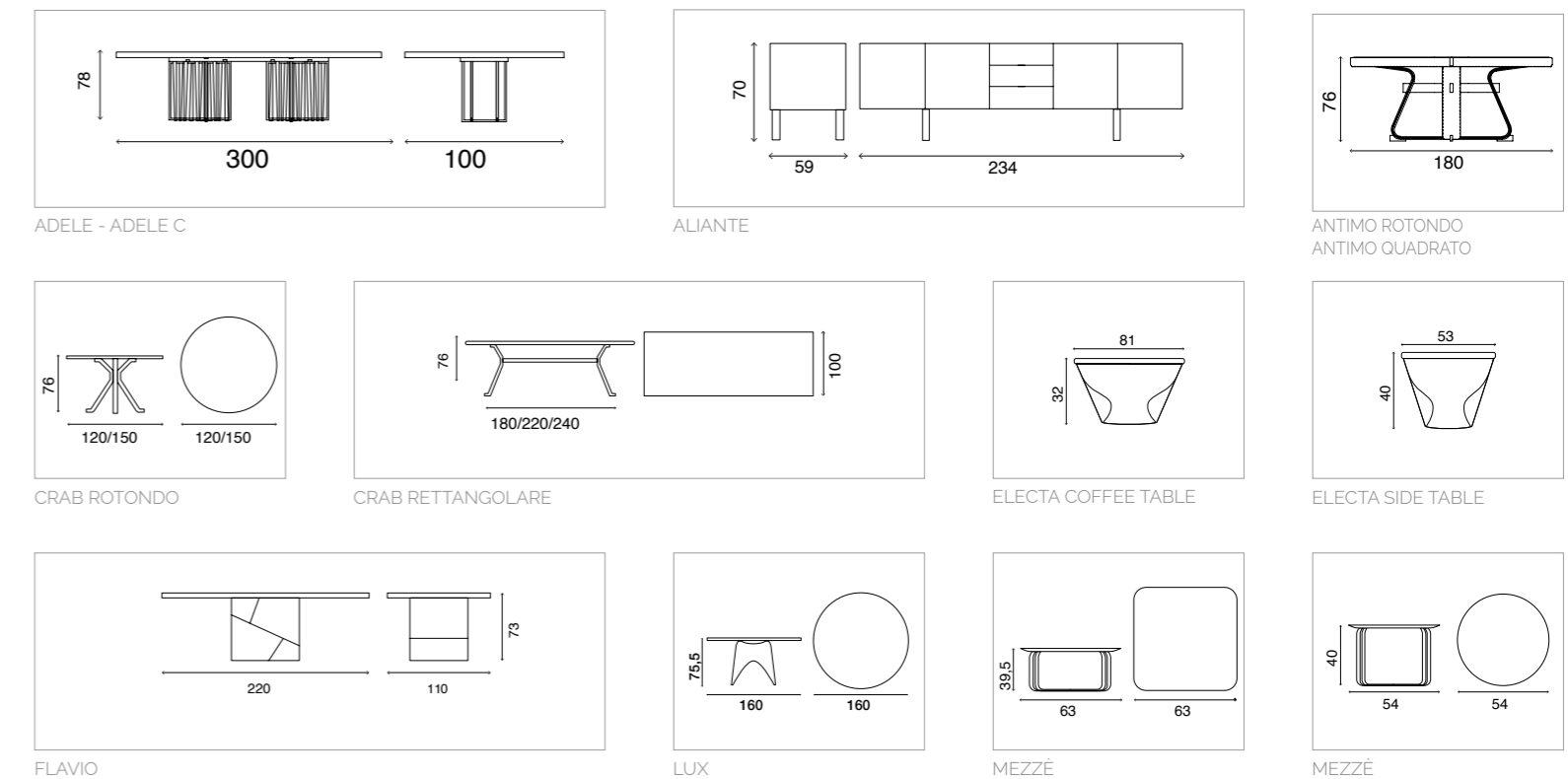

TAVOLI E COMPLEMENTI / TABLES AND COMPLEMENTS

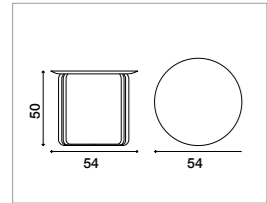

MEZZÈ

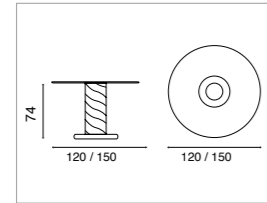

ROLLING

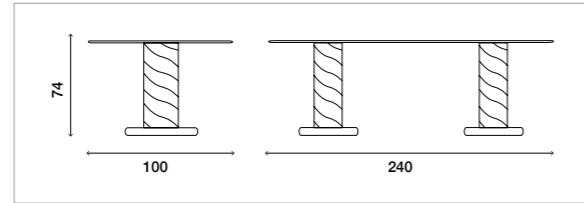

ROLLING 2B

OFFICE

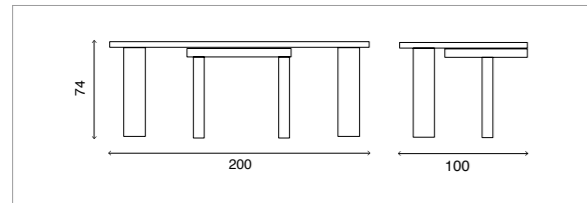

ABACO

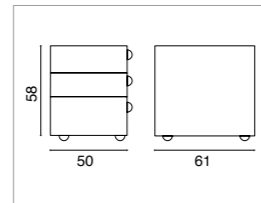

ALA

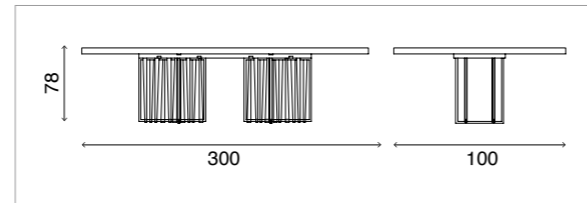

ADELE

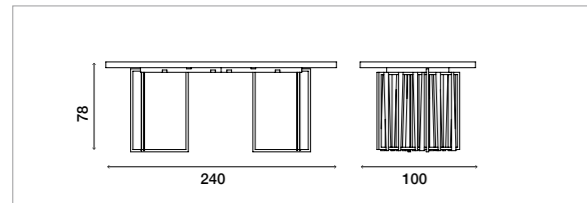

ADELE DESK  
ADELE C DESK

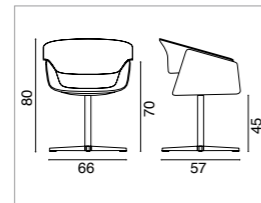

AIRLUX BC

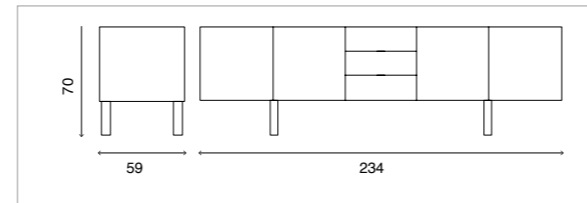

ALIANTE

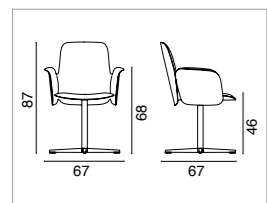

ELECTA BC

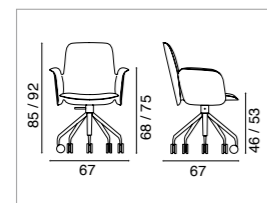

ELECTA BG

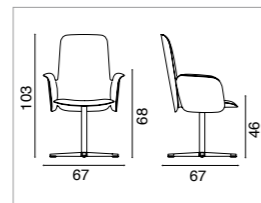

ELECTA TALL BC

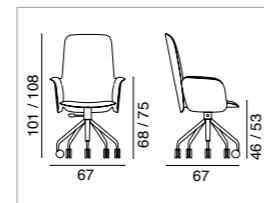

ELECTA TALL BG

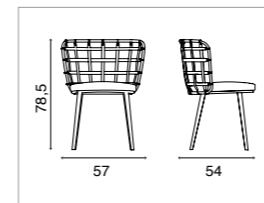

LOLA - LOLA PELLE

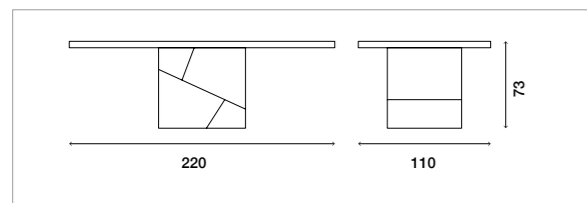

FLAVIO

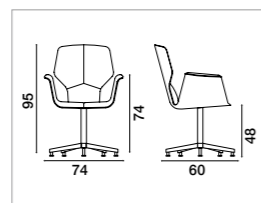

FOSCA BIG ABF

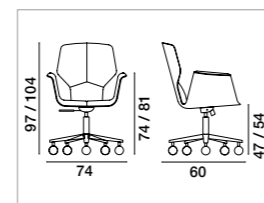

FOSCA BIG ABW

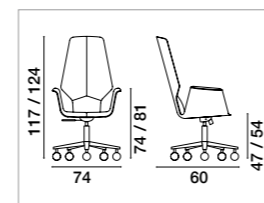

FOSCA BIG TALL ABW

OFFICE

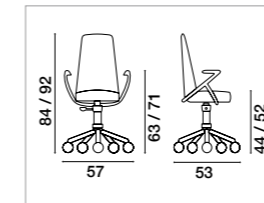

LUNA ABW

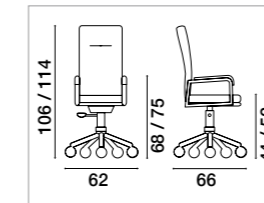

NORMAN D ABW

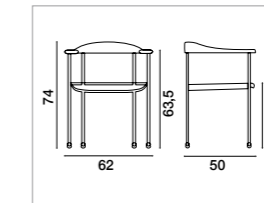

P40

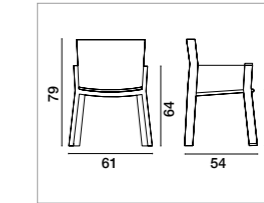

P90

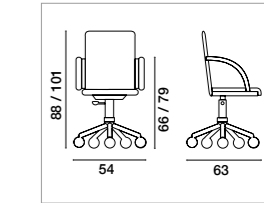

RELAX ABW

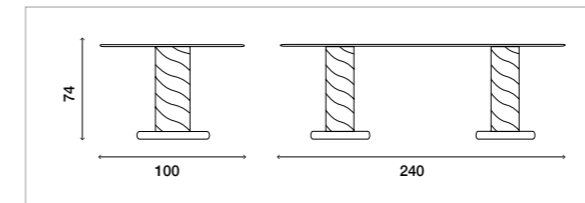

ROLLING 2B

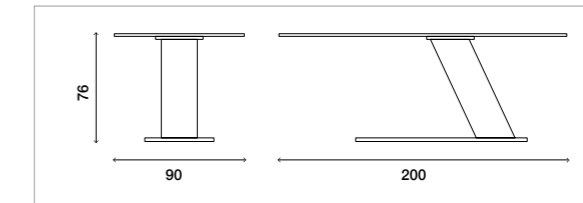

ROLLING DESK

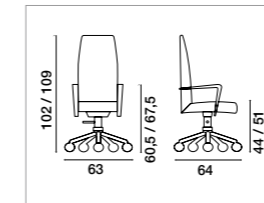

TRESOR ABW

CUOIO PIENO FIORE FASEM LUX / FULL GRAIN HIDE LEATHER FASEM LUX



51 miele / honey 53 petrolio / petrol



54 cioccolato / chocolate

CUOIO PIENO FIORE FASEM SEMI OPACO / FULL GRAIN HIDE LEATHER FASEM SEMI-MATT



05 bianco / white 01 tabacco / tobacco 09 bordeaux / bordeaux 30 verde inglese / english green



22 avorio / ivory 18 naturale / natural 02 nero / black 07 blu scuro / dark blue



11 sabbia / sand 03 rosso bulgaro / bulgarian red 32 grigio argilla / clay grey



23 tortora / dove grey 20 arancio / orange 06 grigio / grey



04 testa di moro / dark brown 10 rosso shocking / shocking red 31 verde salvia / sage green

PELLE FASEM EFFETTO MORBIDO / FASEM SOFT LEATHER SMOOTH EFFECT



505 bianco / white 533 caramello / caramel 619 giallo mostarda / mustard yellow 519 verde / green



522 avorio / ivory 534 terracotta / terracotta 502 nero / black



511 sabbia / sand 503 rosso bulgaro / bulgarian red 504 testa di moro / dark brown



530 perla / pearl 520 arancio / orange 506 grigio / grey



523 tortora / dove grey 535 mogano / mahogany 531 porcellana / porcelain



532 cammello / camel 510 rosso shocking / shocking red 703 ming / ming



679 miele / honey 509 bordeaux / bordeaux 507 blu / blue



501 tabacco / tobacco 524 melanzana / aubergine 692 colbert / colbert



519 verde / green

PELLE FASEM EFFETTO VINTAGE / FASEM SOFT LEATHER VINTAGE EFFECT



541 cuoio / saddle 544 carbone / coal



542 bruno / brown 547 polvere / dust



543 terra / ground

PELLE FASEM NABUK / FASEM SOFT LEATHER NABUK



1707 becco d'anatra / duck bill 1034 bordeaux / bordeaux



1708 cuoio / saddle 1012 grigio antracite / anthracite grey



1704 chocolate forest 1028 nero / black

TESSUTI DEDAR AMOIR LIBRE / DEDAR AMOIR LIBRE FABRICS



AM01 orient



AM20 taupe / mole



AM18 lino / linen

TESSUTI ATLAS DEDAR / DEDAR ATLAS FABRICS



AT01 avorio / ivory

TESSUTI BOUCLÉ / BOUCLÉ FABRICS

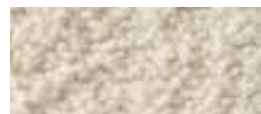

BO01 avorio / ivory



BO02 sabbia / sand



BO03 cammello / camel



BO07 grigio / grey



BO12 nero / black

TRATTAMENTO CON VENICIATURA A POLVERE / POWDER COATED TREATMENT

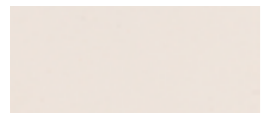

412 bianco opaco

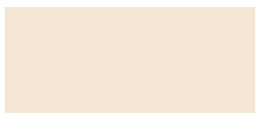

1013 avorio opaco / matt ivory



8019 marrone opaco / matt brown



413 nero opaco / matt black



448 alluminio satinato / satin aluminium

TRATTAMENTO GALVANICO / GALVANIC TREATMENT

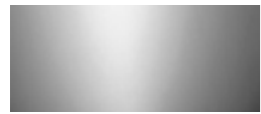

400 cromo lucido / shiny chrome



421 cromo satinato / satin chrome



444 nickel nero / black nickel



490 bronzo lucido / shiny bronze

RIVESTIMENTO SPECIALE CON DOPPIO TRATTAMENTO, A POLVERE E LIQUIDO  
SPECIAL COATING WITH DOUBLE TREATMENTS, POWDER AND LIQUID



495 bronzo opaco / matt bronze



460 ottone opaco / matt brass



470 titanio / titanium



465 ottone striato / striped brass

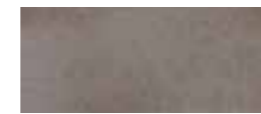

478 peltro / pewter

ALLUMINIO / ALLUMINIUM



438 alluminio spazzolato lucido / polished brushed aluminium

FINITURE LEGNO IN TRE ESSENZE / WOOD FINISHES IN THREE DIFFERENT ESSENCE



401 noce naturale / natural walnut



402 frassino tinto nero a poro aperto / black stained ash with open pores



404 rovere sbiancato / light shade oak

MARMI / MARBLES



800 marmo bianco di Carrara / white Carrara marble



810 marmo bianco arabescato / white arabescato marble



820 marmo Emperador / Emperador marble



830 travertino chiaro classico / classic light travertine

GRANITI / GRANITES



840 granito spazzolato nero opaco / matt black flamed granite

EKOTEK® / EKOTEK®

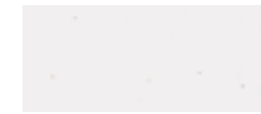

900 ekotek® / white ekotek®

CRISTALLO / GLASS



201 cristallo trasparente temperato / transparent glass



203 cristallo fumé traslucido temperato / translucent smoked glass



204 cristallo bronzato traslucido temperato / translucent bronzed glass



# fasem

FASEM by Green srl

Via Torino snc  
56010 Vicopisano (PI)  
Italy

Tel. +39 050 796152 - +39 050 796256

info@greensrl.it - www.fasem.it

p.iva e cod. Fisc. 01314820505

Styling, Concept and Art Direction  
Paola Annunziata

Photo  
Stefano Tonicello

Graphic Design  
Tap Grafiche

Print  
Tap Grafiche

Thanks to:  
Sigma L2  
Francesco Del Re  
Febo

Tutti i diritti riservati  
All rights reserved  
Fasem

Febbraio 2022