

zanotta:

02 **Elipse**

06 **Noli**

10 **Louise**

14 **Hiro**

22 **Kim**

28 **Fenis**

29 **Carlino**

30 **Albero**

31 **Servomuto**

32 **Cumano**

33 **Marcuso**

34 **Genni**

35 **Susanna**

36 **Cuscini**

Concept,
graphic design
studio
Leonardo Sonnoli,

Photo
Miro Zagnoli

Pre-press
+ Printing
Arti Grafiche Turati

Copyright 2018
© Zanotta spa
All rights reserved

Zanotta spa si riserva di apportare, senza preavviso, modifiche nei materiali, nei rivestimenti, nelle finiture e nei disegni dei prodotti presentati in questo catalogo. Le textures ed i colori dei materiali e delle finiture hanno valore indicativo in quanto soggetti alle tolleranze dei processi di stampa.

Zanotta spa reserves the right to change, without previous notice, materials, covers, finishes and drawings of the products presented in this catalogue. The textures and colours of materials and finishes are indicative as they are depending on the tolerances of the printing process.

2052 *Elipse*

design
Patrick Jouin, 2018



Sedia.
Struttura in lega di alluminio verniciato colore bianco, nero, antracite o amaranto. Sedile e schienale in tecnopolimero a base di polipropilene nei medesimi colori.

Chair.
Aluminum alloy frame, painted in the shades white, black, anthracite or amaranth. Seat and backrest in polypropylene-based technopolymer in the same colours.

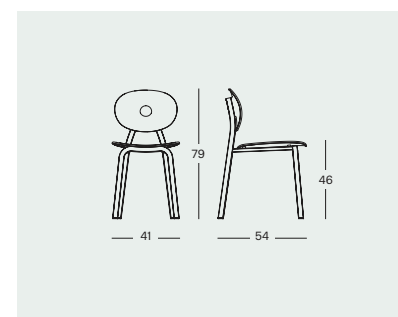

Sedie **Elipse**
nelle varianti
disponibili.

Elipse chairs
in the available
finishes.



2054 *Noli*

design
Ludovica+Roberto Palomba,
2018



Sedia.
Struttura in legno massello di faggio verniciato nei colori antracite, grigio cenere, blu mare, rosa mattone, senape e verde salvia. Sedile imbottito e rivestito in stoffa o pelle, sfilabili.

Chair.
Frame in solid beech wood, painted in the shades anthracite, ash-grey, navy blue, rose-brick, mustard and sage-green. Seat upholstered and covered with removable fabric or leather.

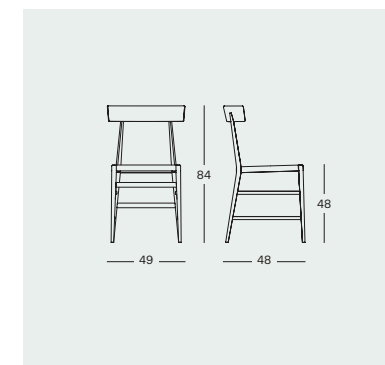

Sedia **Noli** in tessuto Quadrifoglio 27023; struttura in faggio verniciato colore rosa mattone.

Noli chair in fabric Quadrifoglio 27023; frame in beech wood, painted in the shade rose-brick.

Sedia **Noli** in tessuto Tilia 31707; struttura in faggio verniciato colore grigio cenere.

Noli chair in fabric Tilia 31707; frame in beech wood, painted in the shade ash-grey.

Sedia **Noli** in tessuto Tilia 31704; struttura in faggio verniciato colore antracite.

Noli chair in fabric Tilia 31704; frame in beech wood, painted in the shade anthracite.

Sedia **Noli** in tessuto Tito 31841; struttura in faggio verniciato colore verde salvia.

Noli chair in fabric Tito 31841; frame in beech wood, painted in the shade sage-green.

Sedia **Noli** in tessuto Tilia 31740; struttura in faggio verniciato colore blu mare.

Noli chair in fabric Tilia 31740; frame in beech wood, painted in the shade navy blue.

Sedia **Noli** in tessuto Quadrifoglio 27013; struttura in faggio verniciato colore senape.

Noli chair in fabric Quadrifoglio 27013; frame in beech wood, painted in the shade mustard.



887 Louise

design
Philippe Nigro, 2018



Poltroncina.

Struttura in legno massello di faggio laccato nei colori nero o bordeaux. Sedile e schienale in multistrato di pioppo con imbottitura in poliuretano. Rivestimento sfilabile in stoffa o pelle.

Armchair.

Solid beech frame, lacquered in the shades black or burgundy. Seat and backrest made of poplar multilayer with polyurethane upholstery. Removable cover in fabric or leather.

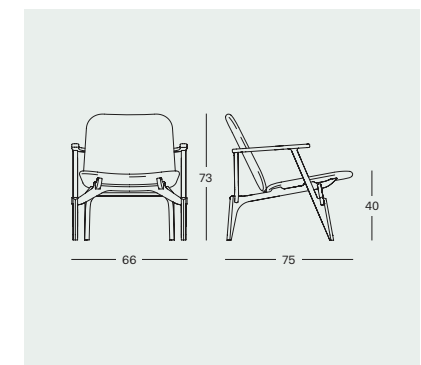

Poltroncina **Louise** in
tessuto Stelvio 24121;
struttura in faggio
laccato bordeaux.

Louise armchair in fabric
Stelvio 24121; burgundy
lacquered beech frame.

Poltroncina **Louise**
in pelle Nappa 0306;
struttura in faggio
laccato nero.

Louise armchair in
leather Nappa 0306;
black lacquered beech
frame.



1327 *Hiro*

design
Damian Williamson,
2018



Divani monoblocco e componibili.
Piedini in lega di alluminio lucidato o nichelsatinato colore naturale o nero. Struttura in acciaio. Molleggio su nastri elastici. Imbottitura struttura in poliuretano/fibra poliestere termolegata. Cuscino seduta in poliuretano a quote differenziate/fibra poliestere termolegata. Cuscino schienale in Solutex®. Rivestimento sfilabile in stoffa o in pelle.

Monobloc and modular sofas.
Aluminum alloy feet, either polished or with natural or black nickel-satin finish. Steel frame. Elastic strips suspension. Frame upholstered with polyurethane/heat-bound polyester fibre. Seat cushion in graduated polyurethane/heat-bound polyester fibre. Back cushion in Solutex®. Removable cover in fabric or leather.



Divano **Hiro** in tessuto Tilia 31740; piedini in alluminio nichelsatinato colore nero. Cuscinetti 52x27 cm e 44x44 cm in tessuto Bright Angle 65440.

Hiro sofa in fabric Tilia 31740; black nickel-satin finished feet. Small cushions 52x27 cm and 44x44 cm in fabric Bright Angle 65440.



Composizione divano **Hiro** in tessuto Tilia 31718; piedini in alluminio nichelsatinato colore naturale. Cuscinetto 52x27 cm in tessuto Bright Angle 65407. Cuscinetti 44x44 cm in tessuto Tilia 31718, in Bright Angle 65407 e in Bright Cube 65315.

Composition of **Hiro** sofa in fabric Tilia 31718; aluminum feet with natural nickel-satin finish. Small cushion 52x27 cm in fabric Bright Angle 65407. Small cushions 44x44 cm in fabric Tilia 31718, in Bright Angle 65407 and in Bright Cube 65315.





Composizione divano **Hiro** in tessuto Tito 31816; piedini in alluminio nichelsatinato colore nero. Cuscinetto 52x27 cm in tessuto Django 65605 Scuro. Cuscinetti 44x44 cm in tessuto Tito 31816 e in Django 65605 Chiaro.

Composition of **Hiro** sofa in fabric Tito 31816; aluminum feet with black nickel-satin finish. Small cushion 52x27 cm in fabric Django 65605 Scuro. Small cushions 44x44 cm in fabric Tito 31816 and in Django 65605 Chiaro.





Composizione divano
Hiro in pelle Super 0913;
 piedini in alluminio lucidato.
 Cuscinetto 52x27 cm in
 tessuto Ellington 65531.
 Cuscinetti 44x44 cm in pelle
 Super 0913, in tessuto Tilia
 31740 e in Ellington 65531.

Composition of **Hiro** sofa
 in leather Super 0913;
 polished aluminum feet.
 Small cushion 52x27 cm
 in fabric Ellington 65531.
 Small cushions 44x44 cm in
 leather Super 0913, in fabric
 Tilia 31740 and in Ellington
 65531.

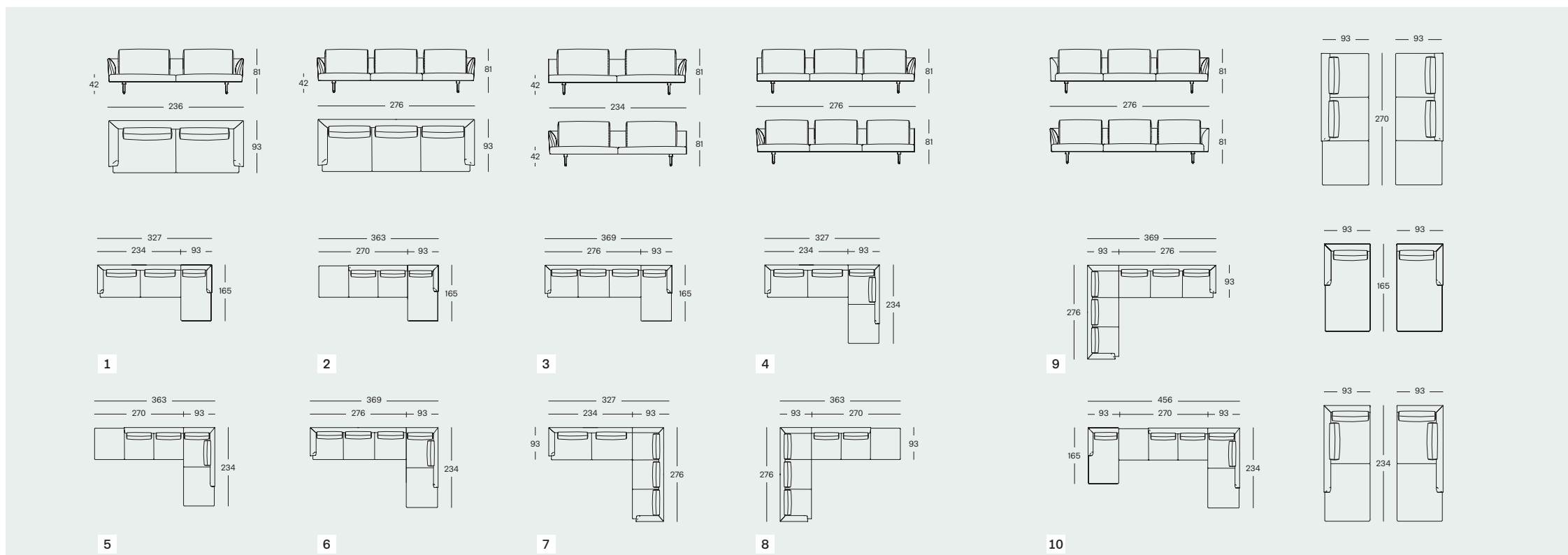

1322 Kim

design
Ludovica+Roberto Palomba,
2018

Divani monoblocco e componibili.
Piedini in lega di alluminio lucidato o nichelsatinato colore naturale o nero. Struttura in legno. Molleggio su nastri elastici. Imbottitura in poliuretano a quote differenziate/fibra poliestere termolegata. Rivestimento sfilabile in stoffa o in pelle. È disponibile un cuscino poggiatesta accessorio.

Monobloc and modular sofas.
Aluminum alloy feet, either polished or with natural or black nickel-satin finish. Wooden frame. Elastic strips suspension. Upholstery in graduated polyurethane/heat-bound polyester fibre. Removable cover in fabric or leather. A headrest cushion is available as option.



Composizione divano **Kim** in tessuto Tilia 31704; piedini in alluminio nichelsatinato colore nero. Cuscinetto 52x27 cm in tessuto Ellington 65527. Cuscinetti 44x44 cm in tessuto Tilia 31704 e in Django 65605 Scuro.

Composition of **Kim** sofa in fabric Tilia 31704; aluminum feet with black nickel-satin finish. Small cushion 52x27 cm in fabric Ellington 65527. Small cushions 44x44 cm in fabric Tilia 31704 and in Django 65605 Scuro.

Composizione divano **Kim** con cuscino poggiatesta in tessuto Vico 27803; piedini in alluminio lucidato. Cuscinetto 52x27 cm in tessuto Django 65642 Scuro. Cuscinetti 44x44 cm in tessuto Vico 27803, in Django 65642 Scuro e in Ellington 65542.

Composition of **Kim** sofa with headrest cushion in fabric Vico 27803; polished aluminum feet. Small cushion 52x27 cm in fabric Django 65642 Scuro. Small cushions 44x44 cm in fabric Vico 27803, in Django 65642 Scuro and in Ellington 65542.





Composizione divano **Kim** con cuscini poggiatesta in tessuto Tito 31829; piedini in alluminio nichelsatinato colore naturale. Cuscinetti 44x44 cm in tessuto Quadrifoglio 27029 e Bright Angle 65429. Cuscinetto 52x27 cm in tessuto Bright Angle 65429.

Composition of **Kim** sofa with headrest cushions in fabric Tito 31829; aluminum feet with natural nickel-satin finish. Small cushions 44x44 cm in fabric Quadrifoglio 27029 and Bright Angle 65429. Small cushion 52x27 cm in fabric Bright Angle 65429.

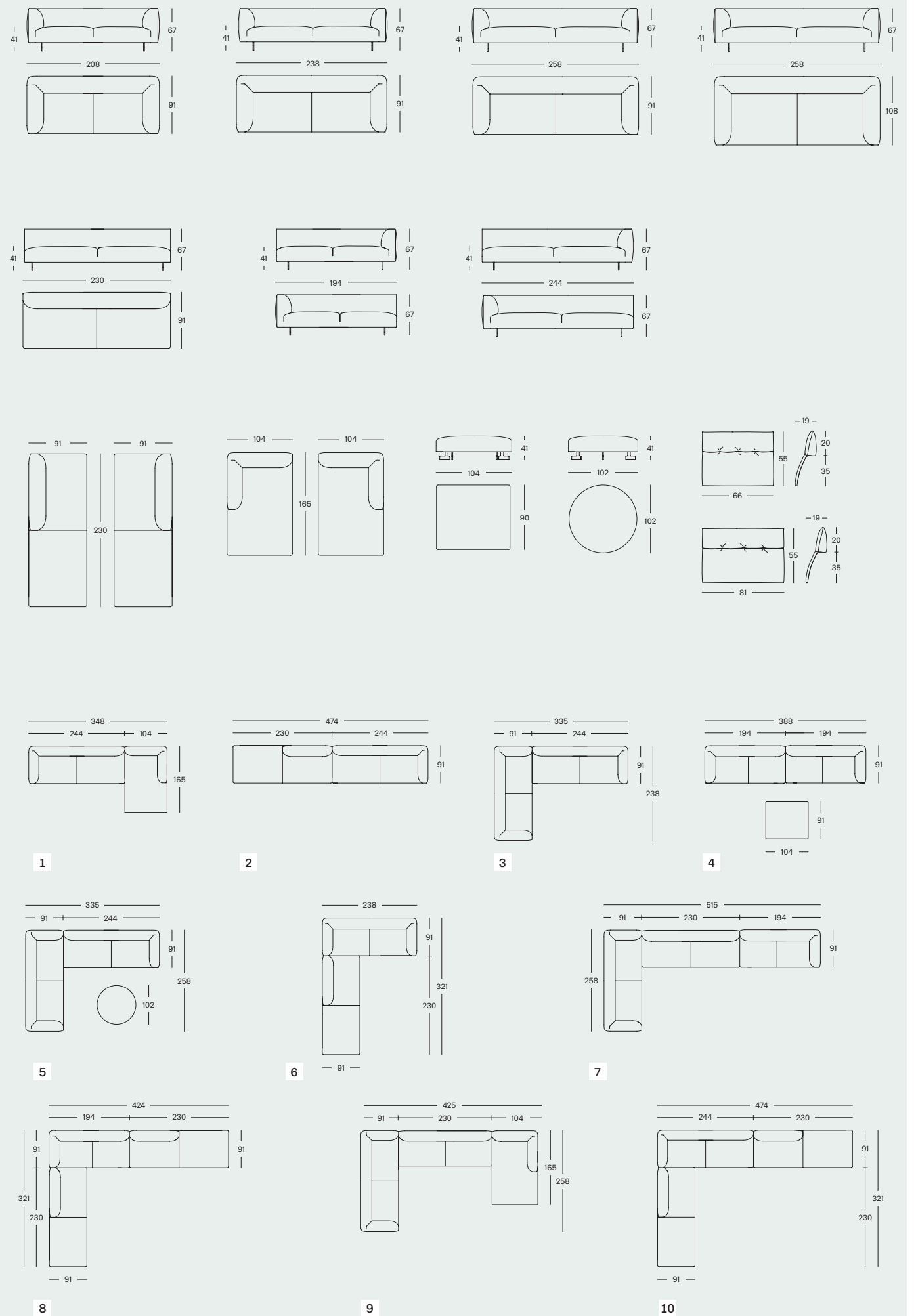

2051 *Fenis*

design
Omaggio a Carlo Mollino,
1959

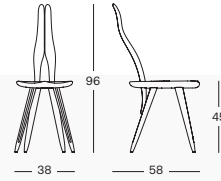

Sedia.
Esemplare numerato.
Struttura in legno
massello di acero
verniciato colore naturale
o nero.

Chair.
Numbered piece.
Frame in natural or black
painted solid maple wood.



335 *Carlino*

design
Omaggio a Carlo Mollino,
1933

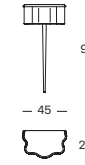

Contenitore di servizio.
Esemplare numerato. Struttura e
cassetto in legno verniciato nei
colori verde salvia, senape o rosa
mattoni. Pianetto d'appoggio in
cristallo nei medesimi colori.

Service storage unit.
Numbered piece. Frame and drawer
in painted wood, in the shades sage-
green, mustard or rose-brick. Plate
glass top in the same colours.



400 *Albero*

design
Achille Castiglioni, 1983

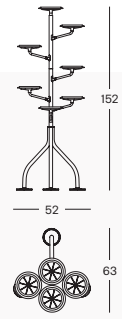

Portavasi smontabile.
Struttura in acciaio verniciato nei colori bianco, nero, amaranto o verde. Piattelli portavasi in poliammide, colore nero. Piedini in polipropilene colore nero.

Demountable flowerpot stand.
Painted steel frame in the shades black, white, amaranth or green. Pot-holder dishes in black polyamide. Black polypropylene feet.



360 *Servomuto*

design
Achille Castiglioni,
della serie Servi
di Achille & Pier Giacomo
Castiglioni, 1974

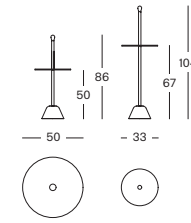

Tavolino di servizio.
Base in polipropilene e asta in acciaio verniciato, colore nero, bianco o amaranto. Pianetto in laminato plastico stratificato, colore bianco/nero, amaranto/grigio, cotto/avio.

Service table.
Base in polypropylene and steel rod painted, colour black, white or amaranth. Top in white/black, amaranth/grey, terracotta/grey blue plastic laminate.



630 *Cumano*

design
Achille Castiglioni, 1978

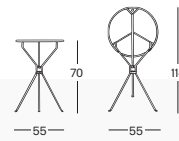

Tavolino pieghevole.
Struttura e piano in acciaio verniciato, colore nero, bianco, amaranto, antracite, corallo, mostarda, azzurro acqua. Giunto scorrevole in ABS.

Folding table.
Painted steel rod frame and top. Colours: black, white, amaranth, anthracite, coral, mustard, light blue. ABS sliding joint.



2530 *Marcuso*

design
Marco Zanuso, 1969

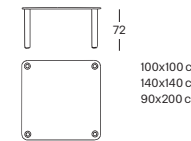

Tavolo.
Piano in cristallo trasparente oppure rivestito in cemento, colore antracite, con finitura acrilica e trattamento di protezione nanotecnologico antimacchia. Gambe in acciaio inox 18/8, abbinato al piano in cristallo trasparente o verniciato colore antracite abbinato al piano rivestito in cemento.

Table.
Plate glass top, either clear or covered in acrylic finish cement, in the shade anthracite, with protective nanotech stain-resistant treatment. Removable legs in 18/8 stainless steel, matching the clear top, or in anthracite painted steel, matching the cement covered top.



920 Genni

design
Gabriele Mucchi, 1935

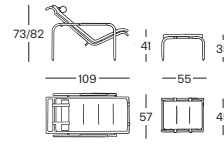

Chaise longue.

Struttura in acciaio cromato, o nichelsatinato colore naturale o nero, oppure verniciato nero. Molleggio su spirali di acciaio. Seduta regolabile su due posizioni. Imbottitura in poliuretano. Rivestimento in pelle.

Lounge chair.

Chromium-plated steel frame or with natural or black nickel-satin finish, or black painted. Suspension on steel springs. Adjustable seat in two positions. Polyurethane upholstery. Leather cover.

Chaise longue **Genni** in pelle Super 0942; struttura in acciaio nichel satinato colore nero.

Genni lounge chair in leather Super 0942; steel frame with black nickel-satin finish.



852 Susanna

design
Gabriele Mucchi, 1983

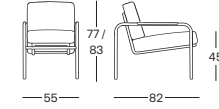

Poltroncina.

Struttura in tubo di acciaio cromato, o nichelsatinato colore naturale o nero, oppure verniciato nero. Telaio portacuscini in acciaio verniciato nero, regolabile su due posizioni. Imbottitura cuscini in poliuretano/fibra poliestere termolegata. Rivestimento cuscini sfilabile in stoffa o pelle. Nella versione con cuscini rivestiti in tessuto, i braccioli sono in pelle 95.

Armchair.

Frame in chromium-plated, or in natural or black nickel-satin finished, or black painted tubular steel. Adjustable two-position cushion support in black painted steel. Cushions upholstery in polyurethane/heat-bound polyester fibre. Removable cushions cover in fabric or leather. The model with fabric covered cushions features the armrests covered with leather 95.



Poltroncina **Susanna** in tessuto Tilia 31754; struttura in acciaio nichel satinato colore nero.

Susanna armchair in Tilia 31754; steel frame with black nickel-satin finish.

Poltroncina **Susanna** in tessuto Tilia 31707; struttura in acciaio nichel satinato colore naturale.

Susanna armchair in fabric Tilia 31707; steel frame with natural nickel-satin finish.

cuscini



65440 bright angle



65605 django chiaro



65657 django chiaro



65407 bright angle



65605 django scuro



65657 django scuro



65429 bright angle



65642 django chiaro



65527 ellington



65315 bright cube



65642 django scuro



65531 ellington



65325 bright cube



65652 django chiaro



65542 ellington



65347 bright cube



65652 django scuro



65556 ellington