

Il Paralume Marina  
*Classic Lighting*



*Il Paralume Marina non produce ma crea.  
Design ed innovazione, ricerca e sviluppo incontrano  
tecniche lavorative di grandi maestri artigiani. La  
fusione d' Ottone in terra, il Cristallo Italiano, il  
vetro di Murano, i Tessuti di Sete e di Organze,  
coronati da Swarovski Elements non ti faranno avere  
nessun compromesso.*

Il Paralume Marina not simply produces but creates. Design and innovation, research and development meet working techniques of the greatest Italian craftsmen. Fusion of brass, Italian crystal, Murano glass, silk and organza fabrics, decorated with Swarovski Elements...

Il Paralume Marina не производит, а творит. Дизайн и инновации, исследования и разработка идут рука об руку с техниками великих мастеров-ремесленников. Литьё латуни «в землю», итальянских хрусталь, муранское стекло, ткани из шелка и органзы, украшенные кристаллами Swarovski Elements, не оставляют компромиссов.



Art. 1967/CH58/LU  
ø 215 cm H 225 cm  
58 x E14 x 40W



*Chandelier made with polished gold fusion brass and cascade of transparent and frosted Murano's Glass. Symbol of handcraft excellence and refinement of materials, design and classic creating a bright masterpiece effect*



Art. 1967/CH22/LU  
Ø 122 cm H 94 cm  
22 x E14 x 40W



*Creations of  
melted brass  
polished gold.  
A very refined  
and valued classic  
that never grows old*

Art.1956/A2/LU  
L 38 cm H 59 cm Sp 21 cm  
2 x E14 x 40W

Art. 1956/CH18/LU  
ø 142 cm H 94 cm  
18 x E14 x 40W



Art. 1956/CH30/LU  
ø 136 H 180 cm  
30 x E14 x 40W



Art. 1956/CH6/LU  
ø 92 cm H 64 cm  
6 x E14 x 40W

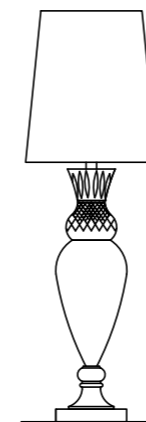

Art. 1953/P  
Pø 26 cm H 82 cm  
1 x E27 x 40W



Art. 1953/LU/AM  
Pø 40 cm H 120 cm  
1 x E27 x 60W  
Nappa N.44 Oro



Art. 1953/LU/VI  
Pø 40 cm H 120 cm  
1 x E27 x 60W  
Nappa N.46



Art. 1953/NL/RS  
Pø 40 cm H 120 cm  
1 x E27 x 60W  
Nappa N.49

Art. 1953/NL/AZ  
Pø 40 cm H 120 cm  
1 x E27 x 60W  
Nappa N.44 Argento

Art. 1953/NL/TR  
Pø 40 cm H 120 cm  
1 x E27 x 60W  
Nappa N.45 Argento



*La fusione d'ottone trasuda d'antico.  
I paralumi di organza ricamata avorio  
su un velo di organza avorio rendono la  
sua linea classica leggera e sfacciatamente  
elegante, i cristalli Swarovski Elements  
sostenuti da perline di vetro trasparente  
ampliano la sua bellezza vibrante.*

Brass fusion attributes an antique touch. The lampshades in hand-embroidered organza on the voile of ivory organza make it's classic line light and elegant, the SWAROVSKI ELEMENTS crystals supported by pearls of transparent glass increase it's vibrant beauty.

Art. 1759/CH12  
ø 103cm  
H 90cm Pø 14cm  
12 x E14 x 25W





Art. 1759/FL  
ø 58 cm H 190 cm Pø 14 cm  
6 x E14 x 25W

Art. 1759/Flambeaux  
ø 65 cm H 95 cm Pø 14 cm  
5 x E14 x 25W



Art. 1759/A3  
ø 40 cm H 55 cm Pø 14 cm  
3 x E14 x 25W



*È un esempio del design  
e del lusso equilibrato e non  
convenzionale de IL PARALUME  
MARINA. Create con cura  
e devozione, le opere sono  
realizzate interamente a  
mano e nella loro singolarità  
racchiudono frammenti di  
anima e di poesia.*

It is a perfect example of balanced and unconventional union of design and luxury of IL PARALUME MARINA. Created with great care and devotion these little masterpieces are made entirely by hand and their uniqueness is in a perfect match of the main components – fragments of soul and poetry.

**Вот отличный пример союза дизайна с умеренной и нетрадиционной роскошью IL PARALUME MARINA. Изделия производятся полностью вручную, с заботой и преданностью их создатели вкладывают в каждое творение часть своей души.**

Art. 1744/FL/ORO24K  
ø 50 cm H 185 cm Pø 16 cm  
5 x E14 x 40W



Art.1744/CH16/ORO24K  
H 160 cm ø 120 cm Pø 16 cm  
16 x E14 x 40W

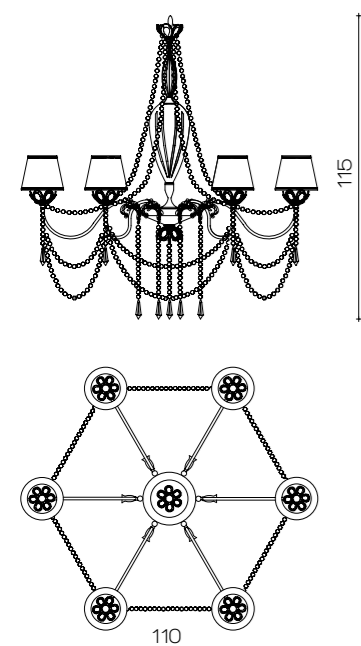

Art. 1744/CH6/ORO24K  
ø 110 cm H 115 cm Pø 16 cm  
6 x E14 x 40W



Art. 1744/A5/V1/ORO24K  
 ø 60 cm H 80 cm  
 Sp 44 cm Pø 16 cm  
 5 x E14 x 40W



Art. 1744/A1/ORO24K  
 Pø 16 cm  
 H 50 cm Sp 25 cm  
 1 x E14 x 40W

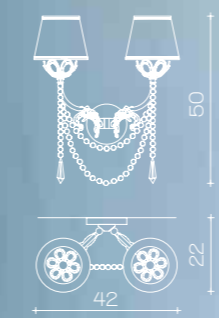

Art. 1744/A2/ORO24K  
 ø 42 cm H 50 cm  
 Sp 22 cm Pø 16 cm  
 2 x E14 x 40W

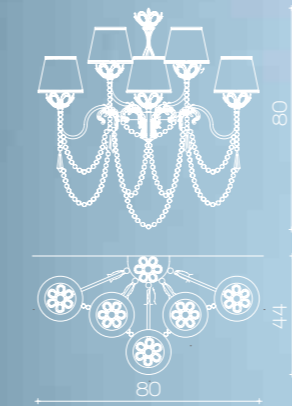

Art. 1744/A5/V2/ORO24K  
 ø 80 cm H 80 cm  
 Sp 44 cm Pø 16 cm  
 5 x E14 x 40W

*La base è in fusione di  
ottone massiccio in finitura  
oro 24, le bobeches sono  
decorate con petali ed inserti  
in cristallo Swarovski  
Elements, mentre il fusto  
trasparente è di cristallo  
fiorentino molato mano,  
una combinazione di  
glamour e di classico, di  
tradizione e modernità.*

The combination of glamour and classic, tradition and modernity: the base is made by fusion of the brass in 24 carat gold cover, the bobeches are decorated with petals and Swarovski Elements inserts while the stock is clear Florentine crystal grinded by hand.

Основа выполнена из латуни под золото 24 карата, bobeches украшены лепестками и Swarovski Elements, в то время как центральная часть сделана из прозрачного флорентийского хрусталя, гравированного вручную. Сочетание гламура и классики, традиции и современности.

Art. 1744/A5/ORO24K  
ø 60 cm H 80 cm  
Sp 44 cm Pø 16 cm  
5 x E14 x 40W

Art. 1744/G/ORO24K  
ø 50 cm H 110 cm Pø 16 cm  
5 x E14 x 40W





*Give you a jewel*



Art. 1622  
ø 50 cm H 90 cm  
Pø 16 cm  
5 x E14 x 40W





24



Art. 2045/A2/LU  
L 34 cm H 58 cm  
2 x E14 x 40W



25

Art. 2045/CH12/LU  
ø 110 cm H 108 cm  
12 x E14 x 40W  
+3 x E14 X Led 5W



Art. 2058/A2/LU  
 L 35 cm H 42 cm Sp 21 cm  
 2 x E14 x 40W

Art. 2058/A3/LU  
 L 42 cm H 55 cm Sp 27cm  
 3 x E14 x 40W



Art. 2070/A2/LU  
 L 28 cm H 29 cm Sp 12 cm  
 2 x E14 x 40W

Art. 2070/A3/LU  
 L 33 cm H 42cm Sp 18 cm  
 3 x E14 x 40W



*Made with Swarovski Elements*

Art. 2099/LU  
L 94 x 48 cm H 7 cm  
+ 50 cm steel cable  
Ceiling base 30 x 8 x 8 cm  
Pannello Led 3000K  
Lumen 4649 36W



Art. 2100/POUFF/G  
L 105 x 58 cm H 59 cm  
Puff in eco-leather and  
Swarovski crystals,  
structure in casting brass  
and italian crystals elements.





Art. 2100/CH6  
 L 95 x 84 cm H 115 cm Pd 18cm  
 Ceiling base 30 x 8 x 8 cm  
 6 x E14 x 40W  
 Pannello Led 3000K  
 Lumen 4649 36W



Art. 2100/TABLE/G  
 L 105 x 58 cm H 46 cm  
 Coffee table in Casting Brass  
 and italian crystals elements.



Art. 2100/CH4  
 L 59 x 60 cm Pd 18 cm  
 Ceiling base 30 x 8 x 8 cm  
 4 x E14 x 40W  
 + Pannello Led 3000K  
 Lumen 2066 16W







Art. 2100/T  
Pd 35 cm H 78 cm  
1 x E27 x 60W

Art. 2100/A  
Pd 18 cm H 57  
cm Sp 22 cm  
1 x E14 x 40W



Art. 2100/TABLE/P  
L 57 x 58 cm H 46 cm  
Coffee table in Casting Brass  
and Italian crystals elements.

Art. 2100/POUFF/P  
L 57 x 58 cm H 59 cm  
Puff in ecopelle and  
Swarovski crystals ,  
structure in Casting Brass  
and Italian crystals elements.

Art.2007/A2/NL  
H 21 cm L 41 cm  
Sp 23 cm  
2 x E14 x 40W



35

Il Paralume Marina

Art.1891  
H 80 cm Pø 45 cm  
1 x E27 x 60W

34

Art. 2007/A1/NL  
L 15 cm H 21 cm  
Sp 28 cm  
1 x E14 x 40W





Art. 2066/TLU  
P oval 50x30 cm H 78 cm  
2 x E14 x 40W



Art. 2066/CH12/LU  
ø 82 cm H 86cm Pø 13cm  
12 x E14 x 40W





Art. 2066/A2/LU  
L 32 cm H 60cm Sp 18cm  
Pø 13cm  
2 x E14 x 40W



Art. 2066/C/LU  
ø 39 cm H 87 cm  
candles not included



Art. 2066/CH8/LU  
ø 60 cm H 70cm Pø 13cm  
8 x E14 x 40W



Art. 2067/T/LU  
Pø 40 cm H 76cm  
3 x E14 x 40W

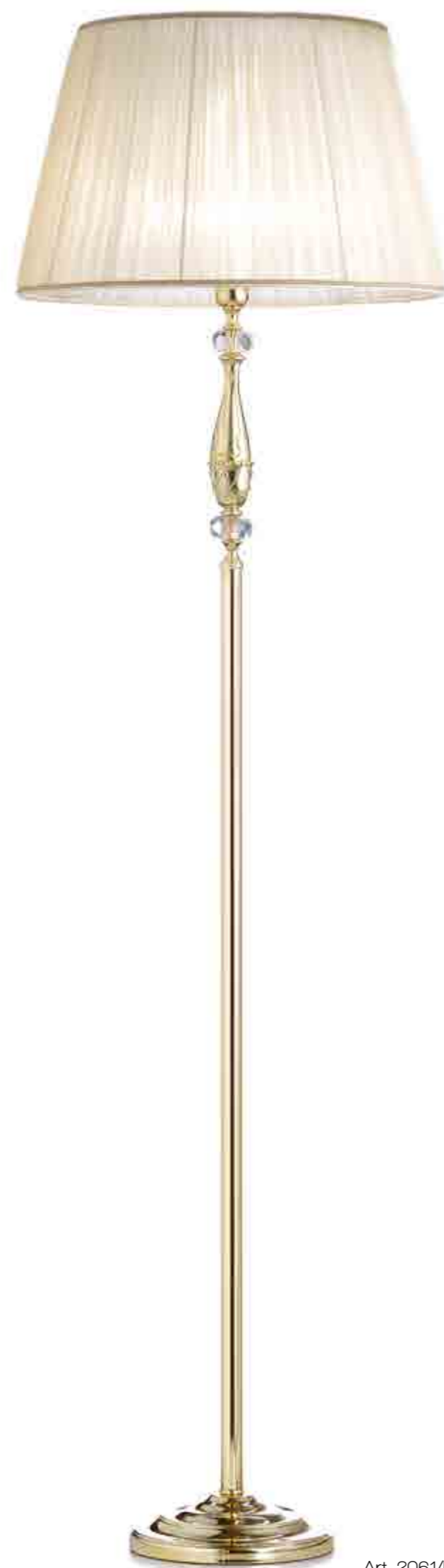

Art. 2061/FL/LU  
Pø 50 cm H 164 cm  
1 x E27 x 60W



Art. 2068/T/LU  
Pø 40 cm H 72cm  
1 x E27 x 60W



*Collection of lighting objects in cast brass  
and Florentine crystal cut by hand*

Art. 1914/CH6/AV  
ø 83 cm H 41 cm  
6 x E14 x 40W

Art. 1904  
Pø 40 cm H 87 cm  
1 x E27 x 60W



44



Art. 1914/CH12/AV  
ø 103 cm H 61 cm  
12 x E14 x 40W



45

Art.1914/A2/AV  
ø 41 cm H 38 cm  
2 x E14 x 40W





Art. 1853/A2/OV  
L 60 cm H 42 cm  
Sp 38 cm Pø 22 cm  
2 x E14 x 40W



Art. 1853/FL/OV  
ø 54 cm H 180 cm  
3 x E27 x 40W



Art.1853/CH5/OV  
ø 80 cm H 43 cm Pø 22 cm  
5 x E14 x 40W





Art. 1853/FLAMBEUX/OV  
ø 50 cm H 92 cm Pø 22 cm  
3 x E14 x 40W



Art. 1853/CH10/OV  
ø 102 cm H 67 cm Pø 22 cm  
10 x E14 x 40W

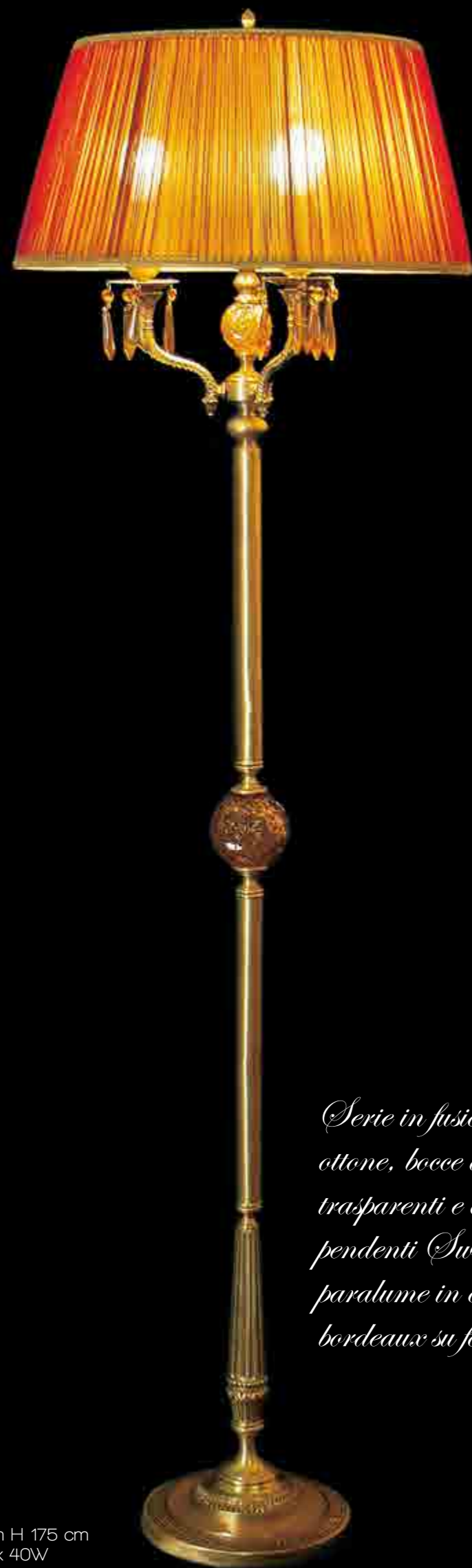

Art. 1077  
Pø 55 cm H 175 cm  
3 x E27 x 40W

*Serie in fusione di  
ottone, bocce di Murano  
trasparenti e oro con  
pendenti Swarovski,  
paralume in chiffon  
bordeaux su federa gialla.*



Art. 931/CH12  
ø 90 cm H 90 cm  
Pø 16 cm  
12 x E14 x 40W





Art.931/L5  
H 45 cm ø max 75 cm  
Pø 16 cm  
5 x E14 x 40W



Art. 931/P  
Pø 25 cm H 48 cm  
1 x E14 x 40W



Art.931/flambeaux  
 ø max 46 cm  
 Pø 14 cm  
 H 71 cm  
 5 x E14 x 40W



Art. 974  
 ø max 38 cm H 30 cm  
 Pø 14 cm  
 2 x E14 x 40W



Art.931/B3  
 Pø 55 cm H 185 cm  
 3 x E14 x 40W

Art. 1629/CH20/AV  
ø 132 Pø 16 cm H 100 cm  
20 x E14 x 40W



Art. 936/BIS  
ø 50 cm H 78 cm  
1 x E27 x 60W



Art. 1629/CH10/AV  
ø 116 cm H 70 cm  
10 x E14 x 40W



Art. 1986/CH6  
ø 68 cm H 61 cm Pø 16 cm  
6 x E14 x 40W



Art. 1985/CH6  
ø 60 cm H 61 cm  
6 x E14 x 40W



Art. 2065/CH8  
ø 86cm H 60cm Pø 16cm  
8 x E14 x 40W

Art. 1941/A2/TR  
L 40 cm H 56 cm  
Sp 21 cm Pø 16 cm  
2 x E14 x 40W



Art. 1941/CH6/OV/TR  
ø 86 cm H 52 cm Pø 16 cm  
6 x E14 x 40W



Art. 1941/CH12/BR/TR  
ø 130 cm H 87 cm Pø 18 cm  
12 x E14 x 40W







*Organza e foglia oro*

Art. 1162/CH10  
ø 83 cm H 74 cm  
Pø 18 cm  
10 x E14 x 40W



Art. 1162/B  
P ovale 60 cm  
H 185 cm  
2 x E27 x 60W

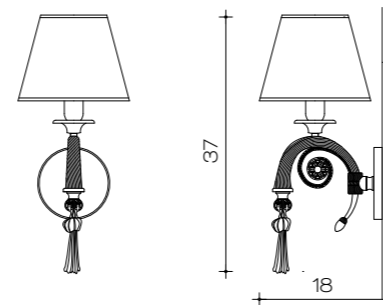

Art. 1162/A  
Pø 18 cm H 37 cm  
Sp 18 cm  
1 x E14 x 40W



Art. 1231/G  
Pø 43 cm H 70 cm  
2 x E14 x 40W

Art. 1231/P  
Pø 35 cm H 58 cm  
2 x E14 x 40W

*Paralumi in organza e foglia oro*



Art. 1162/CH5  
ø max 60 cm H 60 cm  
Pø 18 cm  
5 x E14 x 40W





Art. 635  
Pø 16 cm H 70 cm  
ø max 60 cm  
5 x E14 x 40W



Art. TL28  
ø 55 cm H 175 cm  
3 x E27 x 40W



Art. 635/A  
L 45 cm  
Pø 11 cm  
H 50 cm  
2 x E14 x 40W



Art. 637  
ø 58 cm H 70 cm  
4 x E14 x 40W





Art. 1249/CH5  
ø max 52 cm H 70 cm  
Pø 16 cm  
5 x E14 x 40W



Art. 1249/A  
ø max 35 cm  
H 50 cm Pø 16 cm  
2 x E14 x 40W





Art. 1529  
cm L 50 cm H 70  
Pø 16 cm  
2 x E14 x 40W



Art. 1529/FL  
L 70 cm H 175 cm  
2 x E14 x 40W



Art. 1529/A2  
L 50 cm H 44 cm  
Pø 16 cm  
2 x E14 x 40W



Art. 1529/CH8  
ø 90 cm H 75 cm  
Pø 18 cm  
8 x E14 x 40W

*Lampadario dai colori tenui e morbidi, con elementi in fusione di ottone finito in oro vecchio e vetro colore seta di Murano, collane di perle di fiume e paralumi in chiffon avorio su fodera avorio delineati da una passamaneria in velluto beige coronati da fiocchetti in velluto.*

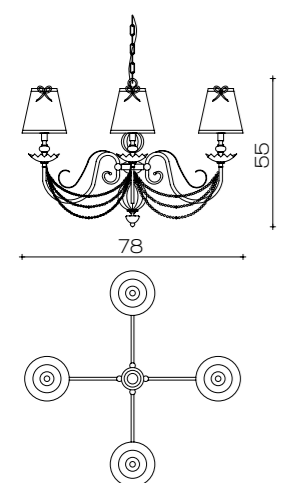

Art. 1794/CH4  
 ø 78 cm H 55 cm  
 Pø 16 cm  
 4 x E14 x 40W

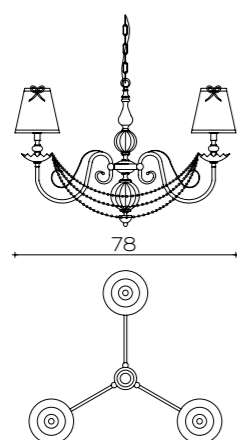

Art. 1794/CH3  
 ø 78 cm H 45 cm  
 Pø 16 cm  
 3 x E14 x 40W

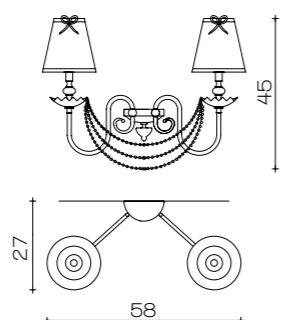

Art. 1794/A2  
 L 58cm H 45 cm  
 Sp 27 cm Pø 16 cm  
 2 x E14 x 40W

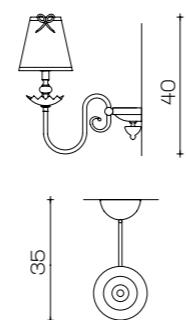

Art. 1794/A1  
 H 40 cm Sp 35 cm  
 Pø 16 cm  
 1 x E14 x 40W



Chandelier by soft and smooth colours, elements made of fused brass finished in old gold colour and Murano glass of tender silk colour; necklaces of river pearls and lampshades in ivory chiffon on the ivory lining outlined by velvet trimming and crowned with velvet bows.

Люстра в мягких и нежных тонах с элементами из латуни под состаренное золото и муранского стекла цвета шёлка, ожерелья из речного жемчуга и абажуры из шифона цвета слоновой кости на светлой подкладке, оборка и банты из бархата .

Art.1794/CH6  
 H 76 cm ø 106 cm Pø 16 cm  
 6 x E14 x 40W

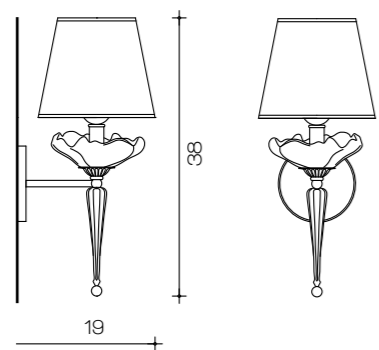

Art. 777/A  
 Pø 16 cm H 38 cm  
 Sp 19 cm  
 1 x E14 x 40W



Art. 791  
 Pø 40 cm H 175 cm  
 1 x E27 x 60W

Art. 777/CH10  
 ø 92 cm H 75 Pø 16 cm  
 1 x E14 x 40W



Art. 777/CH5  
ø 74 cm H 56 cm Pø 16 cm  
5 x E14 x 40W



Art. 785  
Pø 30 cm H 67 cm  
1 x E27 x 40W

Art. 786  
Pø 25 cm H 53 cm  
1 x E14 x 40W





Art. 2057/CH12/LU  
ø114 cm H 74 cm Pø 16cm  
12 x E14 x 40W



Art. 2057/CH6  
ø 96 cm  
H 62cm Pø 16cm  
6 x E14 x 40W



Art. 2057/A3/LU  
L 64 cm H 50 cm  
Sp 36cm Pø 16cm  
3 x E14 x 40W



84

Art. 1879/FL/AV  
Pø 55 cm H 190 cm  
5 x E14 x 40W



85

Art. 1879/CH16/AV  
ø 106 cm H 100 cm Pø 18 cm  
16 x E14 x 40W



*Questa composizione frutto di alto artigianato italiano, e' emozionante nella cura dei dettagli della fusione di ottone in argento invecchiato e nei paralumi in chiffon avorio cuciti su una fodera di seta rosa. I pendenti di cristallo rosa Swarovski Elements donano un vivace ed elegante tocco contemporaneo.*

*Full made in Italy.*

This composition is a creation of high Italian craftsmanship. The attention to detail is impressive: silver-plated brass fusion, lampshades made of ivory chiffon sewn on the pink silk lining, pink crystal pendants by Swarovski Elements. All these components create an elegant and lively contemporary look.

**Эта композиция – шедевр высокого итальянского мастерства. Вас впечатлит присущее ей внимание к деталям, начиная от покрытия латуни под серебро и абажуров из бежевого шиффона на розовой шелковой подкладке и заканчивая розовыми подвесками Swarovski Elements, придающими всей коллекции элегантный современный вид. Full made in Italy.**

Art. 1689/FL/AV  
Pø 57 cm H 190 cm  
5 x E14 x 40W



Art. 1689/CH16/AV/RS  
ø 106 cm H 120 cm Pø 18 cm  
16 x E14 x 40W



Art. 1689/A1/V1  
 Pø 18 cm H 45 cm  
 Sp 37 cm  
 1 x E14 x 40W

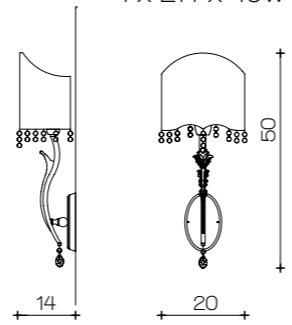

Art. 1689/A1/V2  
 L20 cm H 50 cm  
 Sp 14 cm  
 1 x E14 x 40W

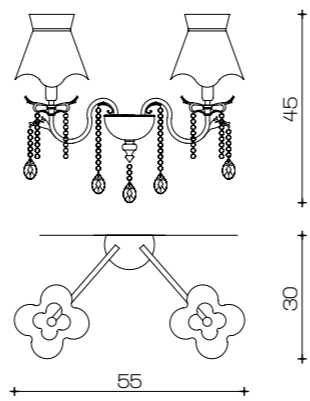

Art. 1689/A2  
 L 55 cm H 45 cm  
 Sp 30 cm Pø 18 cm  
 2 x E14 x 40W



Art. 1689/P/OV/RS  
 Pø 20 cm H 47 cm  
 1 x E14 x 40W

Art. 1689/CH5/AV/RS  
 ø 100 cm H 90 cm Pø 25 cm  
 5 x E14 x 40W

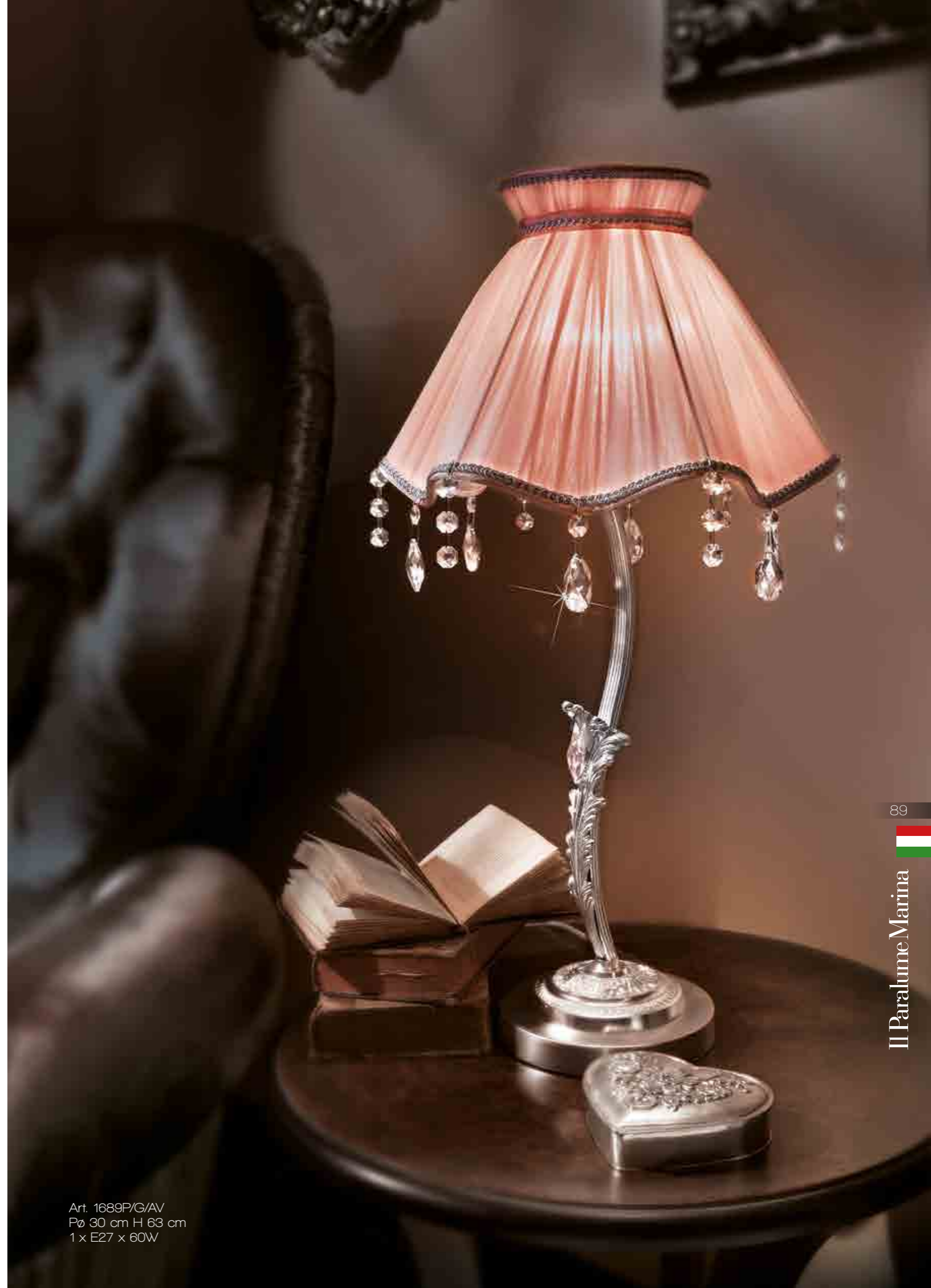

Art. 1689P/G/AV  
 Pø 30 cm H 63 cm  
 1 x E27 x 60W





Art. 1845/A2/ORO24K  
L 60 cm H 33 cm Sp 35 cm  
Pø 20 cm  
2 x E14 x 40W



Art. 1975/CH18/LU  
ø 144 cm H 128 cm  
18 x E14 x 40W



Art. 1845/CH8/ORO24K  
ø 84 cm H 90 cm  
Pø 20 cm  
8 x E14 x 40W



Art. 1845/FL/ORO24K  
ø 80 cm H 180 cm  
Pø 20 cm  
5 x E14 x 40W



Art. 1983/A2/ORO24K/RO  
 L 60 cm H 33 cm  
 Pø 20 cm Sp 35 cm  
 2 x E14 x 40W



Art. 1983/CH8/ORO24K/RO  
 ø 81 cm H 90 cm  
 8 x E14 x 40w





Art. 1983/CH6/ORO24K/RO  
ø 81 cm H 90 cm  
6 x E14 x 40w

Art. 1983/FL/ORO24K/RO  
ø 81 cm H 180 cm  
5 x E14 x 40w

Art. 1983/CH18/ORO24K/RO  
ø 152 cm H 126 cm  
18 x E14 x 40W





Art. 1880/CH16/AV  
 ø 102 cm H 102 cm  
 16 x E14 x 40W

*Fantastico e al contempo prezioso e popolare, decorativo ed espressivo assieme, questo lampadario è in elementi di fusione di ottone cromato e rose di cristallo fiorentino pinzate a mano. I paralumi in organza viola rifiniti con passamaneria di perle e di cristalli trasparenti, creano atmosfere delicate e morbide.*

Creative and precious, decorative and expressive at the same time, this chandelier is made of the elements fused in chromed brass and Florentine crystal roses clamped by hand. The lampshades in violet organza with pearls on the trimming and transparent crystals create delicate and soft atmosphere.

Популярная и ценная, экспрессивная и декоративная, воплощение яркого и неординарного воображения, эта люстра выполнена из хромированной латуни и вручную сделанных роз из флорентийского хрусталя. Абажуры из фиолетовой органзы, очерченные прозрачными кристалликами, создают мягкую и деликатную атмосферу.



Art. 1774/A1  
 Sp 18 cm H 43 cm  
 Pø 14 cm  
 1 x E14 x 40W



Creative and precious, decorative and expressive at the same time, this chandelier is made of the elements fused in chromed brass and Florentine crystal roses clamped by hand. The lampshades in violet organza with pearls on the trimming and transparent crystals create delicate and soft atmosphere.

Популярная и ценная, экспрессивная и декоративная, воплощение яркого и неординарного воображения, эта люстра выполнена из хромированной латуни и вручную сделанных роз из флорентийского хрустала. Абажуры из фиолетовой органзы, очерченные прозрачными кристалликами, создают мягкую и деликатную атмосферу.



*Fantastico e al contempo prezioso e popolare, decorativo ed espressivo assieme, questo lampadario è in elementi di fusione di ottone cromato e rose di cristallo fiorentino pinzate a mano. I paralumi in organza viola rifiniti con passamaneria di perle e di cristalli trasparenti, creano atmosfere delicate e morbide.*

Art.1774/A3  
H 56 cm ø 78 cm  
Sp 42 cm Pø 14 cm  
3 x E14 x 40W

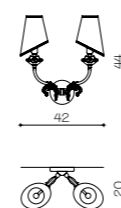

Art.1774/A2  
H 44 cm ø 42 cm Pø 14 cm  
2 x E14 x 40W

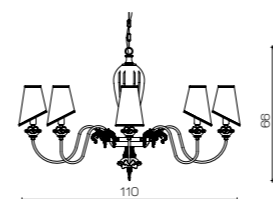

Art. 1774/CH8  
ø 110 cm H 66 cm Pø 14 cm  
8 x E14 x 40W

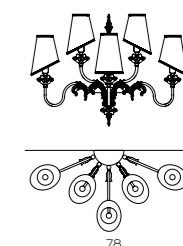
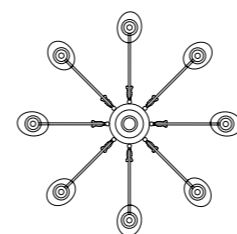

Art.1774/A5  
H 56 cm ø 78 cm  
Sp 42 cm Pø 14 cm  
5 x E14 x 40W

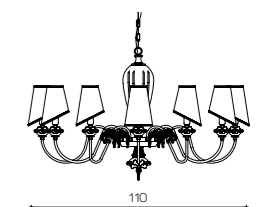

Art. 1774/CH12  
ø 110 cm H 66 cm Pø 14 cm  
12 x E14 x 40W

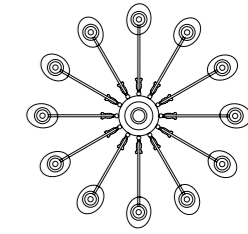



Art. 1774/CH6  
ø 84 cm H 55 cm Pø 14 cm  
6 x E14 x 40W



Art. 1774/CH12  
ø 110 cm H 85 cm Pø 14 cm  
12 x E14 x 40W





Art. 1140  
P. ovale  
35 x 26 cm H 50 cm  
1 x E27 x 60W



Art. 1138  
Pø 40 cm H 180 cm  
1 x E27 x 60W





Art. 2034/CH36/LU  
Ø 250 cm H 300 cm  
36 x E14 x Led 5W

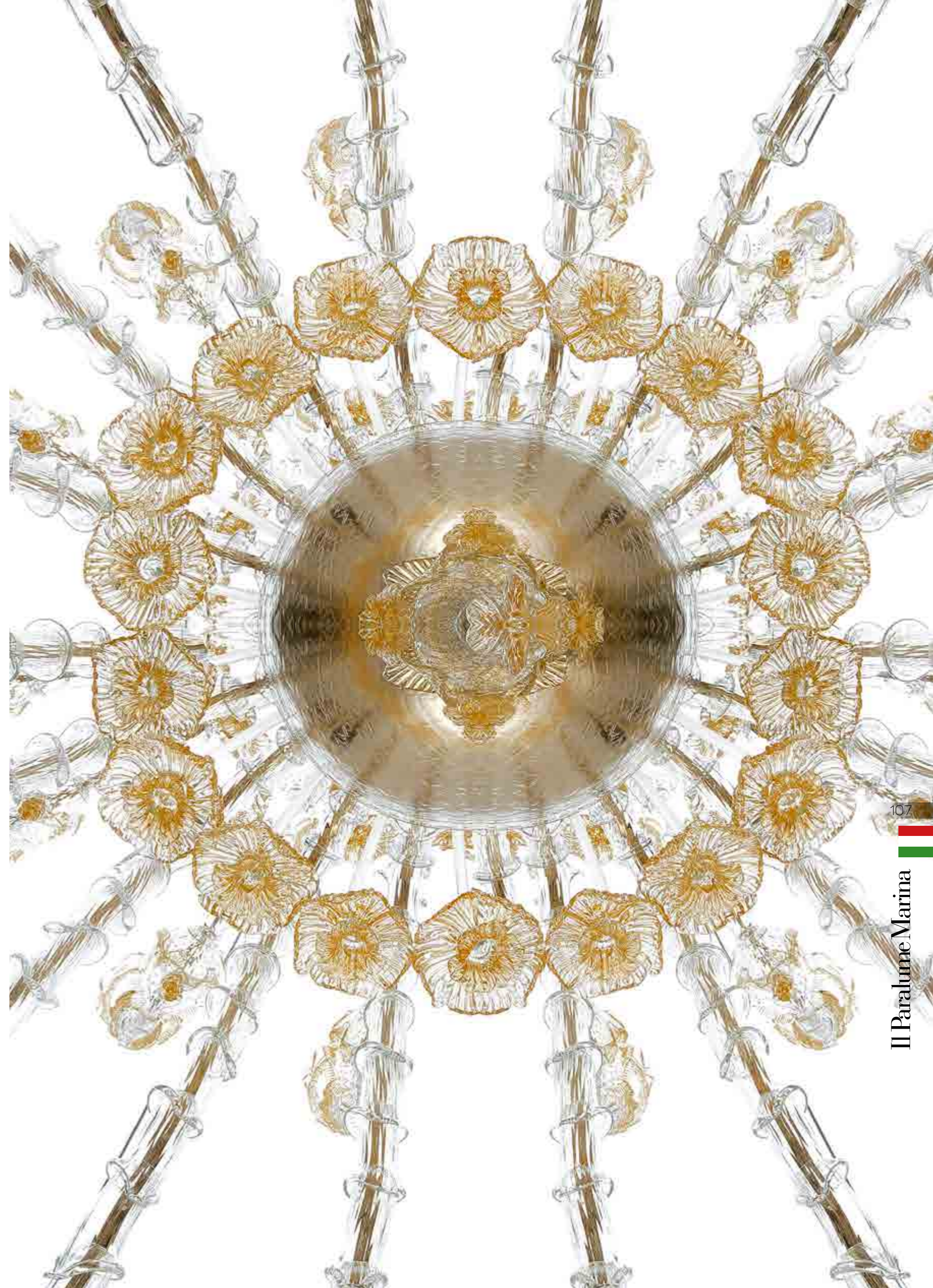



Art. 2034/A2  
 ø 45 cm H 50 cm Sp 35cm  
 2 x E14 x Led 5W



Art. 2034/CH18/LU  
 ø 160 cm H 200 cm  
 18 x E14 x Led 5W





Art. VM 526  
ø 80cm H 75cm  
6 X E14 X 40w



Art. 2036/CH8/KR  
ø 104 cm H 106 cm  
8 x E14 x 40W





Art. 1964/CH18/NL  
ø 85 cm H 136 cm  
18 x E14 x 40W



Art. 2035/A2/KR  
L 40 cm H 40 cm Sp 35 cm  
2 x E14 x 40W





Art. 2035/CH9/KR  
Ø 115 cm H 140 cm  
9 x E14 x 40W



*La magia del vetro soffiato, la padronanza del maestro vetraio, il sapore d'antico e di opera d'arte, sono tutti elementi caratterizzanti questo Lampadario in Murano in style Ca' Rezzonico, dalle decorazioni floreali scultoree frutto di alta maestria artigianale vetraia che sa emozionare.*

The magic of blown glass, the skill of the master glassmaker, the flavour of antique ... all these are characterizing elements of this chandelier in Murano glass made in Ca' Rezzonico style, a masterpiece with sculptured floral decorations - creation of the high glass-working craftsmanship, the beauty that excites the senses.

Магия выдутого стекла, привкус обворожительной старины...эти черты присущи данной люстре из муранского стекла, выполненной в стиле Ca' Rezzonico. Произведение искусства с цветной лепкой от мастеров-стеклодувов, которое наполняет сердце эмоциями...





Art. 1850/BI/TR  
Pø 43 cm H 105 cm  
1 x E27 x 60W

Art. 1850/KR/BLU  
Pø 43 cm H 105 cm  
1 x E27 x 60W

Art. 1850/ORO24K/FUME'  
Pø 43 cm H 105 cm  
1 x E27 x 60W

Art. 1850/FO/RO  
Pø 43 cm H 105 cm  
1 x E27 x 60W





Art. 1850/CH12/ORO24K/NR  
 ø 107 cm H 73 cm Pø 16 cm  
 12 x E14 x 40W

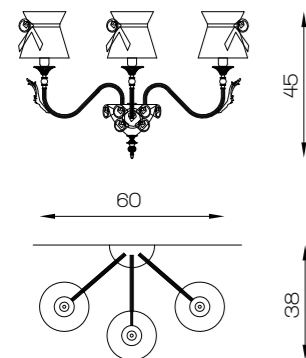

Art. 1850/A3  
 L 60 cm H 45 cm  
 Sp 38 cm  
 3 x E14 x 40W

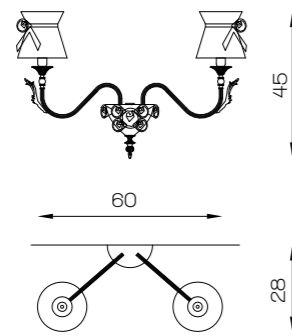

Art. 1850/A2  
 L 60 cm H 45 cm  
 Sp 28 cm  
 2 x E14 x 40W

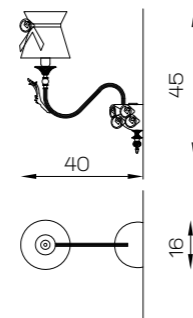

Art. 1850/A1  
 Pø 16 cm H 45 cm  
 Sp 40 cm  
 1 x E14 x 40W

Paralume in seta  
 avorio su fodera dorata

Art. 1850/P/ORO24K/FUMÉ  
 Pø 32 cm H 82 cm  
 1 x E27 x 60W

Art. 1850/G/ORO24K/FUMÉ  
 Pø 43 cm H 105 cm  
 1 x E27 x 60W



Art. 1850/CH12/AV/RS  
ø 107 cm H 73 cm Pø 16 cm  
12 x E14 x 40W



*Paralume in seta  
avorio su fodera argentata*

Art. 1850/AV/RS  
Pø 43 cm H 105 cm  
1 x E27 x 60W





Art. 1850/FO/RO  
Pø 43 cm H 105 cm  
1 x E27 x 60W



Paralume in seta  
avorio su fodera dorata

Art. 1850/CH12/FO/RO  
ø 107 cm H 73 cm Pø 16 cm  
12 x E14 x 40W





Art. 1850/BI/TR  
Pø 43 cm H 105 cm  
1 x E27 x 60W



Art. 1842/CH6/BI  
ø 77 cm H 57 cm Pø 19 cm  
6 x E14 x 40W



Art. 1850/KR/BLU  
Pø 43 cm H 105 cm  
1 x E27 x 60W



Art. 1843/CH6/KR/BLU  
ø 77 cm H 57 cm Pø 19 cm  
6 x E14 x 40W





Art. 1844/CH6/OV  
ø 77 cm H 57 cm Pø 19 cm  
6 x E14 x 40W



Art. 1870/CH6/OV  
ø 77 cm H 57 cm Pø 19 cm  
6 x E14 x 40W



Art. 1850/OV/AM  
Pø 43 cm H 105 cm  
1 x E27 x 60W





Art. 1876  
ø 20 cm H 20 cm  
1 x E27 x 60W

Art. 1877  
ø 18 cm H 20 cm  
1 x E27 x 60W

Art. 1878  
ø 18 cm H 20 cm  
1 x E27 x 60W



Art. 1981  
ø 50 cm H 150 cm  
7 x E14 x 60W



Art. 1982  
ø 50 cm H 150 cm  
7 x E14 x 60W



*Piantana e lampada in vetro di  
Murano ambra trasparente con  
rose fatte a mano, paralume organza  
tortora su seta avorio scuro.*

Art. 1547/FL  
Pø 55 cm H 180 cm  
2 x E27 x 60W  
Nappa N. 30



Art. 1547/G  
Pø 40 cm H 73 cm  
1 x E27 x 60W



Art. 1775/FL  
ø 60 cm H 220 cm  
5 x E14 x 60W

*Dai delicati toni del  
bianco, questa  
collezione in fiori di vetro e  
di perle di Murano offre  
una luminosità morbida  
ed intensa regalando  
atmosfera dal  
sapore d'antico.*

Delicate white tones of this collection with glass flowers and Murano beads offer a unique light - soft and intense at the same time - which creates a special atmosphere with slightly antique flavour.

**Деликатные оттенки белого, цветы и жемчужины из муранского стекла этой коллекции бросают уникальный свет – мягкий и насыщенный одновременно, создавая особую атмосферу с легким привкусом античности.**



Art. 1775/CH6  
ø 76 cm H 148  
10 x E27 x 60W

Art. 1871  
ø 73 cm H 46 cm  
6 x E27 x 40W



Art. 1872  
ø 49 cm H 30 cm  
4 x E27 x 40W



Art. 1775/P  
ø 31 cm H 64 cm  
1 x E27 x 60W

Art. 1775/A  
L32 cm H 35 cm Sp 15 cm  
4 x G9 x 40W





Collection is characterized by delicate tones of lighting elements fixed to the chandelier painted in white, by the harmonious and essential line decorated with roses and drops in Murano glass, crystals and Swarovski Elements. The lampshades, made of ivory lace outside and pongè bosco lining inside are completed with the trimming of transparent pearls that all together create soft and romantic atmosphere.

**Тона этой коллекции мягкие и delicate благодаря гармоничному сочетанию металла в белом покрытии, капель и роз из муранского стекла и кристаллов Swarovski Elements. Дополняют линию абажуры из pongè bosco, одетые в изящное кружево цвета слоновой кости и обрамленные прозрачными жемчужинами. Все элементы этой композиции создают мягкую романтическую атмосферу.**



Art. 1627/CH24/BI/RS  
ø 120 cm H 115 cm  
Pø 14 cm  
24 x E14 x 40W





Art. 1627/A5  
 ø 55 cm H 50 cm  
 Sp 15 cm  
 Pø 14 cm  
 5 x E14 x 40W

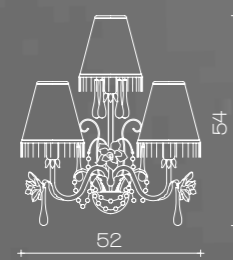

Art. 1627/A3  
 ø 52 cm H 54 cm  
 Sp 15 cm  
 Pø 14 cm  
 3 x E14 x 40W



Art. 1627/A1  
 L 18 cm H 35 cm  
 Sp 15 cm  
 Pø 14 cm  
 1 x E14 x 40W

Art. 1627/A2/BI/RS  
 L 40 cm H 40 cm  
 Sp 15 cm  
 Pø 14 cm  
 2 x E14 x 40W



Art. 1627/CH5/BI/RS  
 ø 60 cm H 70 cm  
 Pø 14 cm  
 5 x E14 x 40W





Off

On



*Collezione dai delicati toni di elementi illuminanti legati al lampadario verniciato in bianco, dalla linea armonica ed essenziale decorato con rosette e gocce in vetro di Murano e cristalli Elements di Swarovski. I paralumi in pizzo avorio su federa Pongè bosco, rifiniti con passamaneria in perline trasparenti creano un'atmosfera morbida e romantica.*

Art. 1627/CH12  
ø 87 cm H 90 cm Pø 14 cm  
12 x E14 x 40W



Art. 1743/CH12/OV  
ø 87 cm H 90 cm  
Pø 14 cm  
12 x E14 x 40W

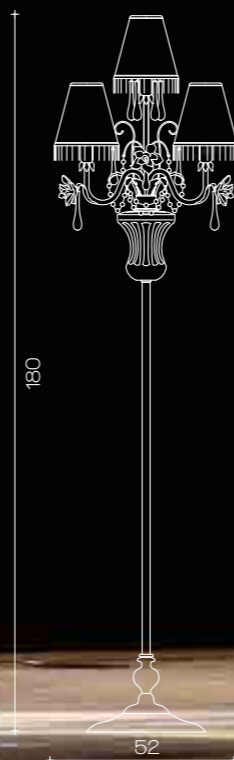

Art. 1627/FL  
ø 52 cm H 180 cm Pø 14 cm  
5 x E14 x 40W

Art. 1627  
ø 52 cm H 82 cm  
Pø 14 cm  
5 x E14 x 40W



Art. 1823/A2  
 H 60cm ø 48 cm  
 Pø 20 cm  
 2 x E14 x 40W

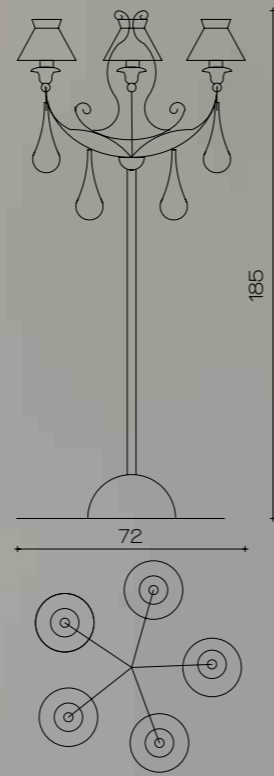

Art. 1823/FL  
 ø 72 cm H180 cm  
 Pø 20 cm  
 5 x E14 x 40W

Art. 1823/CH8  
 H 106cm ø 104 cm  
 Pø 20 cm  
 8 x E14 x 40W



Art.1823/Flambeaux  
 ø 36 cm H 82 cm  
 Pø 20 cm  
 3 x E14 x 40W





Art. 1631/CH12/KR  
 ø 160 cm H 65 cm Pø 18 cm  
 12 x E14 x 40W



*Serie di elementi legata al  
 lampadario in vetro di Murano  
 trasparente addolcito da rose  
 forgiate in nastro di rete cromata  
 dai profili morbidi e paralumi in  
 spicchi di chiffon grigio su fodera  
 in crepon bianco che infondono  
 romanticismo ed armonia in ogni  
 ambiente.*

The series of elements that recall the chandelier of transparent Murano glass enriched by roses forged in the stripes of the soft chromed net and lampshades in grey chiffon slices on the white crepon lining infuse romance and harmony in any ambiance.

Ряд изделий, созданных в сочетании с люстрой из прозрачного муранского стекла и украшенных розами на лентах из тончайшей мягкой хромированной металлической сетки, дополнен абажурами из серого шифона на белом стероп. Такая композиция вселит романтическое настроение в любое помещение.

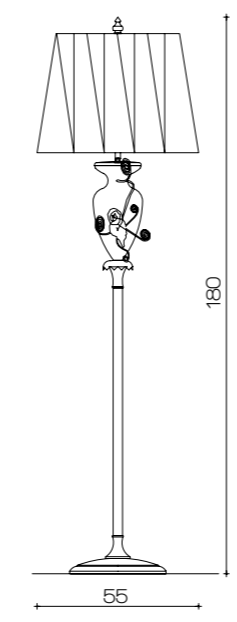

Art. 1631/FL  
 Pø 55 cm  
 H 180 cm  
 2 x E27 x 60W

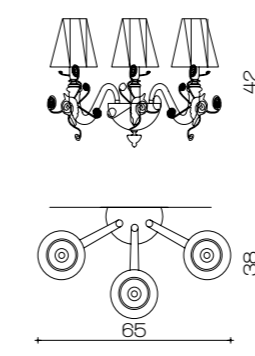

Art. 1631/A3  
 L 65 cm H 42 cm  
 Sp 38 cm Pø 16 cm  
 3 x E14 x 40W

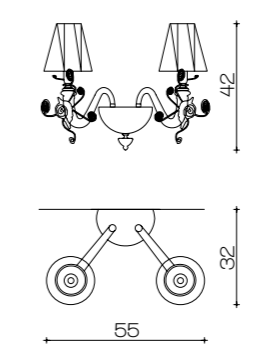

Art. 1631/A2  
 L 55 cm H 42 cm  
 Sp 32 cm Pø 16 cm  
 2 x E14 x 40W

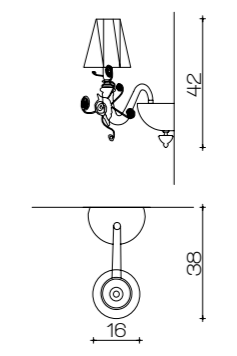

Art. 1631/A1  
 Pø 16 cm H 42 cm  
 Sp 38 cm  
 1 x E14 x 40W



Art. 1631  
Pø 45 cm H 81 cm  
1 x E27 x 60W

Art. 1631/CH4/OV  
ø 65 cm H 45 cm Pø 16 cm  
4 x E14 x 40W



*Raffinato lampadario in vetro di Murano trasparente e ottone finito in oro vecchio e applicazione di rose in metallo cromato, paralumi in seta avorio.*

Elegant chandelier made of transparent Murano glass and brass finished in old gold, application of roses in chromed metal, ivory silk lampshades

**Изящная люстра из прозрачного муранского стекла и латуни в покрытии под состаренное золото с аппликацией роз из тонких нитей хромированного металла, абажуры из шёлка цвета слоновой кости.**

Art. 1631/CH8/OV  
ø 120 cm H 58 cm Pø 16 cm  
8 x E14 x 40W



*Lampadario in vetro di Murano trasparente dalle  
proporzioni equilibrate, arricchito con bobeches ed ele-  
menti in cristallo SWAROVSKI ELEMENTS coronato con  
paralumi in organza avorio. Un'opera scultorea che  
illumina gli ambienti anche quando è spento.*

Chandelier in transparent  
Murano glass with balanced pro-  
portions, embellished with bobeches and crystal SWAROVSKI  
ELEMENTS, crowned with  
ivory organza lampshades. A  
sculptural creation that illuminates  
the room even when turned off.

Art. 1797/CH18  
H 130 cm ø 116 cm  
Pø 16 cm  
18 x E14 x 40W

Люстра из прозрачного муранского  
стекла с умело балансированными пропорциями,  
украшенная bobeches и кристаллами SWAROVSKI ELEMEN-  
TS, коронованная абажурами из органзы цвета слоновой кости.  
Произведение скульптурного искусства, которое освещает  
помещение даже при выключенном свете.



Art. 2050/CH10  
ø 90 cm H 92 cm Pø 16 cm  
10 x E14 x 40W

Art. 2050/A3  
L 50 cm H 77 cm  
Sp 26cm Pø 16 cm  
3 x E14 x 40W





*Lampadario in  
vetro di Murano.  
Trasparente dalle  
linee sinuose ed  
equilibrate, definito con  
elementi in cromo od  
in oro coronato da  
paralumi cuciti in seta  
pura bianca su fodera  
bianca, passamaneria  
in cristalli luminosi  
Swarovski Elements*



Art. 1801/CH15/KR  
Ø 116 cm H 83 cm  
15 x E14 x 40W



Art. 1790/CH15/KR  
Ø 123 cm H 83 cm  
PØ 16 cm  
15 x E14 x 40W

Clear Murano glass chandelier by sinuous and balanced lines with elements in chrome or gold crowned with the lampshades sewn in pure white silk on the white lining, trimming in sparkling crystals by Swarovski Elements

Извилистые линии этой люстры из прозрачного муранского стекла гармонично подчеркнуты элементами в золотом и серебряном вариантах. Абажурами шитыми из чистого белого шёлка на белой подкладке с тесьмой из сияющих кристалликов Swarovski Elements.



Art. 1792/CH9  
ø 82 cm H 73 cm  
9 x E14 x 40W



162 *Clear Murano glass chandelier by  
sinuous and balanced lines with elements  
in chrome or gold crowned with the  
lampshades sewn in pure white silk on the  
white lining, trimming in sparkling crystals  
by Swarovski Elements*



163 *Art 1793/CH9  
ø 93 cm H 73 cm Pø 16 cm  
9 x E14 x 40W*



Art. 1793/FL  
ø 76 cm H 185 cm  
Pø 16 cm  
6 x E14 x 40W



Art. 1793/G  
Pø 45 cm H 85 cm  
1 x E27 x 60W



Art. 1793/A  
L 60 cm Pø 16 cm H 47 cm  
2 x E14 x 40W



Art. 1955/A2/LU  
L 52 cm H 60 cm Sp 34 cm  
2 x E14 x 40W



Art. 1955/PLU  
Pø 34 cm H 70 cm  
1 x E27 x 40W

Art. 1955/G/LU  
Pø 46 cm H 95 cm  
1 x E27 x 60W

*Chandelier made with  
transparent gold Murano  
glass with flames.*



Art. 1955/CH12/LU  
ø 120 cm H 80 cm  
12 x E14 x 40W





Art. 1955/FL/LU  
Pø 48 cm H 188 cm  
2 x E27 x 60W



Art. 1955/CH6/LU/GR  
ø 80 cm H 85 cm  
6 x E14 x 40W



Art. 1352/TA  
ø max 75 cm H 90 cm  
Pø 18 cm  
6 x E14 x 40W



Art.1352/FL  
ø 75 cm H 185 cm  
Pø 18 cm  
6 x E14 x 40W



Art.1352/CH18  
ø 120 cm H 100 cm  
Pø 18 cm  
18 x E14 x 40W





Art. 1352/A3  
ø max 75 cm H 70 cm  
Pø 18 cm  
3 x E14 x 40W



Art. 1352/CH6  
ø max 75 cm  
H 70 cm Pø 18 cm  
6 x E14 x 40W



Art.TL58  
ø 45 cm H 76 cm  
1 x 27 x 60W



Art.TL64  
ø 72 cm H 64 cm  
6 x E14 x 40W



Art. 1462/A  
ø 40 cm H 110 cm Sp 20 cm  
4 x E14 x 40W



Art. 1462/FL  
ø 40 cm H 180 cm  
4 x E14 x 60W



*Cascata con  
foglie in vetro  
di Murano  
madreperlato e  
perle Swarovski  
Elements*

Art. 1462  
ø 55 cm H 80 cm  
8 x E14 x 40W



*Lampadario in vetro di Murano  
madreperlato, paralume in organza  
di seta azzurra con passamaneria  
in roselline bianche.*

Art. 1455  
ø 90 cm H 80 cm  
Pø 14 cm  
9 x E14 x 40W





Art. 1381 Rosa  
 ø 70 cm H 80 cm  
 6 x E14 x 60W



*Lampadario in vetro di  
 Murano bianco, paralume  
 in chiffon nero su federa avorio  
 con passamaneria in palline  
 di perline nere e bianche.*

Chandelier in white Murano glass,  
 lampshade in black chiffon on ivory lining  
 and a white-black braid made  
 on little balls of pearls.

Люстра из белого Муранского стекла,  
 абажур чёрного шифона на подкладке цвета  
 слоновой кости с чёрным и белым бисером  
 на борде.

Art. 1381 Bianco  
 ø 80 cm H 80 cm Pø 16 cm  
 6 x E14 x 40W



Art.1210  
Ø 80 cm H 62 cm  
6 x E14 x 40W



Art.1262  
Ø 90 cm H 100 cm  
9 x E14 x 40W



Art. 1803/CH10/KR  
ø 106 cm H 70 cm  
10 x E14 x 40W



Art. 1711/FL/KR/TR  
ø 60 cm H 174 cm  
5 x E14 x 40W



Art. 1802/CH10/KR  
ø 85 cm H 70 cm  
10 x E14 x 40W

*Collezione in elementi di cristallo trasparente e ottone cromato, pendenti Swarovski Elements. Ironicamente decorati da un paralume colorata viola, rossa o fumè. Questo inedito ed imprevedibile elemento, non servirà solo a indirizzare la luce e a diffonderla in maniera armoniosa, ma anche a stupire e a rafforzare le nostre scelte di interior design.*

The collection of elements with chrome-plated brass, clear crystal and pendants Swarovski Elements. Ironically the lampshades have been made with coloured organza of violet, red or smoked colours. This surprising and unpredictable element will serve not only to spread the light in a smooth and harmonious manner but also to reinforce our choices of interior design.

Коллекция с элементами из прозрачного хрусталя и хромированной латуни, подвески - Swarovski Elements. С легкой иронией абажуры были выполнены из цветной органзы фиолетового, красного и пепельного цветов. Этот неожиданный выбор служит не только для того, чтобы поразить гармоничностью распространяемого света, но и для укрепления нашей позиции в interior design.

Art. 1711/CH12/KR/GR  
ø 90 cm H 140 cm  
12 x E14 x 40W



Art. 1711/CH12/KR/RO  
ø 90 cm H 140 cm  
12 x E14 x 40W



Art. 1711/G/KR/GR  
ø 50 cm H 75 cm  
5 x E14 x 40W



Art. 1711/G/KR/RO  
ø 50 cm H 75 cm  
5 x E14 x 40W



Art. 1711/G/KR/M  
ø 50 cm H 75 cm  
5 x E14 x 40W



Art. 1711/CH12/KR/M  
ø 90 cm H 140 cm  
12 x E14 x 40W



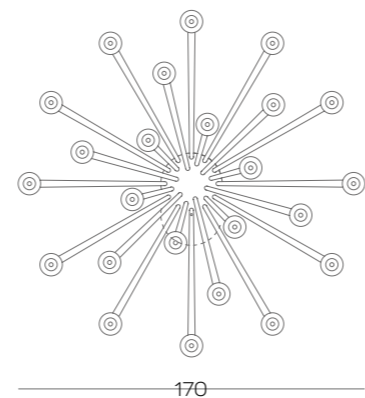

170

Art. 1761/CH24  
 ø 170 cm H 215 cm  
 Pø 16 cm  
 24 x E14 x 40W

*Collezione di lampadari in cristallo trasparente e pendenti di Cristallo Swarovski Elements, paralumi in organza avorio. Un'eleganza che si rivela nell'equilibrata combinazione tra strutture essenziali e forme avvolgenti disegnate dai cristalli pendenti.*

Collection of the chandeliers made of clear crystal and Swarovski Elements pendants, ivory organza lampshades. Elegance that reveals itself in a well-balanced combination of essential structures and fascinating forms drawn by crystal pendants.

**Коллекция люстр из прозрачного хрустала с подвесками Swarovski Elements, абажуры из органзы цвета слоновой кости. Элегантность, воплощенная в комбинации эссенциальных структур и обволакивающих форм кристалльных подвесок.**

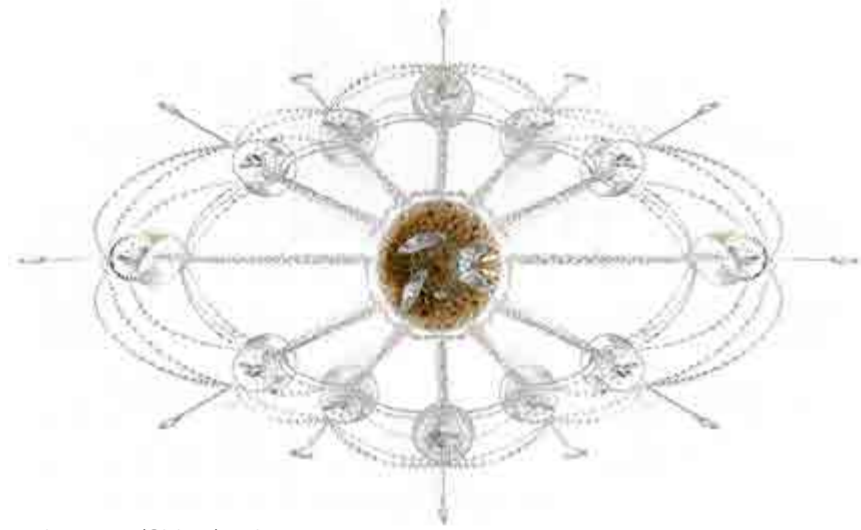

Art. 1761/CH12/ovale  
L 165 x 95 cm H 115 cm Pø 16 cm  
12 x E14 x 40W

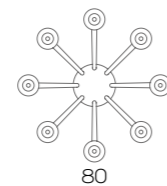

Art. 1761/CH8  
ø 80 cm H 90  
cm Pø 16 cm  
8 x E14 x 40W

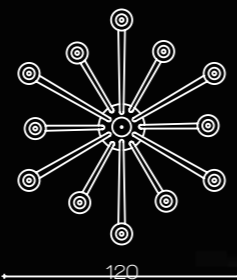

Art. 1761/CH12  
ø 120 cm H 150 cm Pø 16 cm  
12 x E14 x 40W







Art. 1742/CH40/KR  
ø 180 cm H 180 cm Pø 14 cm  
40 x E14 x 25W





Art. 1742/CH8/KR  
 ø 86 cm H 75 cm Pø 14 cm  
 8 x E14 x 25W

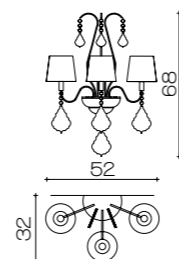

Art. 1742/A3/KR  
 ø 52 cm H 68 cm Pø 14 cm  
 3 x E14 x 25W

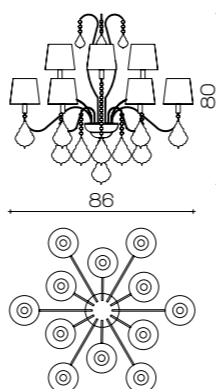

Art. 1742/CH12/KR/V2  
 ø 86 cm H 80 cm Pø 14 cm  
 8 x E14 x 25W

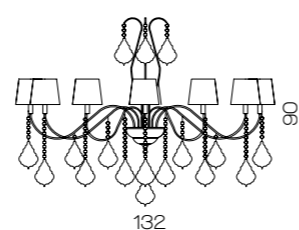

Art. 1742/CH12/KR/V1  
 ø 132 cm H 90 cm Pø 14 cm  
 12 x E14 x 25W

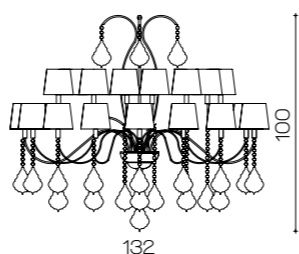

Art. 1742/CH24/KR  
 ø 132 cm H 100 cm Pø 14 cm  
 24 x E14 x 25W



Art. 1742/Flambeaux/KR  
 ø 75 cm H 100 cm Pø 14 cm  
 8 x E14 x 25W



Art. 1742/FL/KR  
 ø 86 cm H 210 cm Pø 14 cm  
 8 x E14 x 25W



*Questa collezione, in nastri di ottone cromato ha un forte impatto emozionale dovuto alle medaglie di agata che vibrano di colori e forme sempre inattese e spontanee.*

This collection with chromed brass stripes has a strong emotional impact due to agate medal decoration that vibrate unexpected and spontaneous colours and shapes.

Эта коллекция с лентами из хромированной латуни впечатляет созерцателя медалями из агата, спонтанно вибрирующими неожиданными цветами и формами.



COLORE FUXIA



COLORE BLU



COLORE ORANGE

Art. 1710CH40/KR/RS  
ø 180cm H 180cm  
40x14x25W  
peso Kg.40



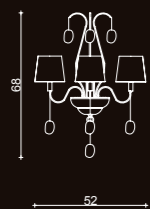

Art. 1710/A3/KR/RS  
ø 52 cm H 68 cm  
Pø 14 cm  
3 x E14 x 25W

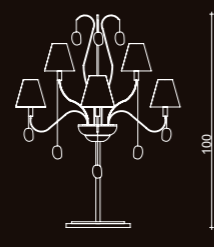

Art. 1710/FLAMBEAUX/KR/RS  
ø 75 cm H 100 cm  
Pø 14 cm  
8 x E14 x 25W

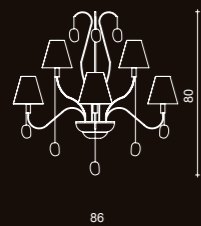
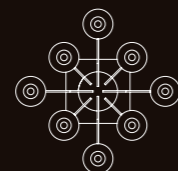

Art. 1710/CH8/KR/RS/V2  
ø 86 cm H 80 cm  
Pø 14 cm  
8 x E14 x 25W

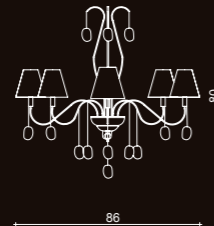
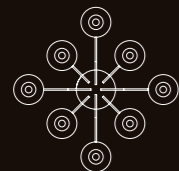

Art. 1710/CH8/KR/RS/V1  
ø 86 cm H 80 cm  
Pø 14 cm  
8 x E14 x 25W

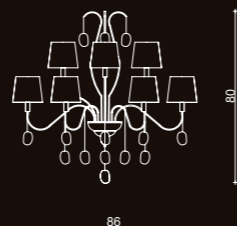
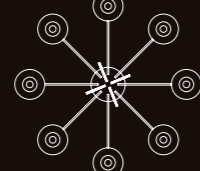

Art. 1710/CH12/KR/RS/V2  
ø 86 cm H 80 cm  
Pø 14 cm  
12 x E14 x 25W

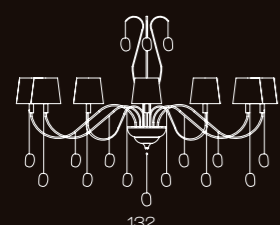

Art. 1710/CH12/KR/RS/V1  
ø 132 cm H 90 cm  
Pø 14 cm  
12 x E14 x 25W

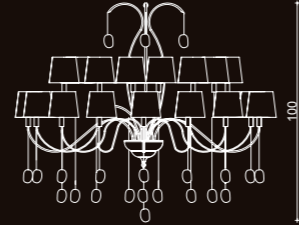
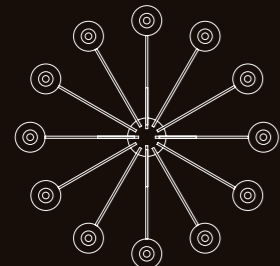

Art. 1710/CH24/KR/RS  
ø 132 cm H 100 cm  
Pø 14 cm  
24 x E14 x 25W

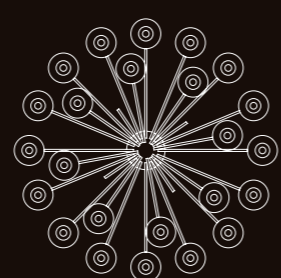

Art. 1710/FL/KR/RS  
ø 86cm H 210cm Pø14cm  
8x E14x 25W



200

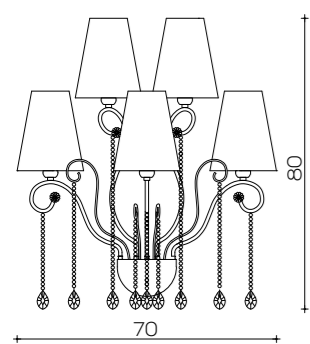

Art. 1630/A5  
 ø 70 cm H 80 cm Pø 18 cm  
 5 x E14 x 40W  
 Wall Sconce



201



Art. 1630/CH6/AV  
 ø 115 cm H 62 cm Pø 18 cm  
 6 x E14 x 40W  
 Antique silver

Art. 1630/CH18/AV  
 ø 115 cm  
 H 100 cm Pø 18 cm  
 18 x E14 x 40W  
 Antique silver



Art. 1630/P  
Pø 25 cm H 48 cm  
1 x E14 x 40W

Art. 1630/G  
Pø 40 cm H 65 cm  
1 x E27 x 60W

Plantana con paralume in  
organza tortora e fodera avorio.

Art.1389/FL  
Pø 55 cm H 180 cm  
2 x E27 x 60W  
Nappa N. 10



Art.1630/CH6/OV  
ø 115 cm H 65 cm  
Pø 18 cm  
6 x E14 x 40W





Art. 1244/A2  
ø max 50 cm H 50 cm  
2 x E14 x 40W



Art. 1244/CH12  
ø 80 cm H 90 cm  
Pø 16 cm  
12 x E14 x 40W





Art. 1319/FL KR  
ø 74 cm H 180 cm  
Pø 16 cm  
6 x E14 x 40W



Art. 1319/CH8  
ø 110 cm H 78 cm  
Pø 18 cm  
8 x E14 x 40W







Art. 1319  
 ø max 76 cm H 70 cm  
 Pø 16 cm  
 6 x E14 x 40W



Cristallo Swarovski



Organza di seta con  
 inserti Swarovski

Art. 1320  
 ø max 60 cm H 70 cm Pø 16 cm  
 3 x E14 x 40W



Art. 1248  
Pø 55 cm H 180 cm  
2 x E27 x 60W



*Paralume in chiffon di seta  
ricamata su fondo giallo*

*Fusione d'ottone con  
pendenti cristallo*

Art. 1341  
ø max 50 cm H 72 cm  
Pø 14 cm  
4 x E14 x 40W



Art. 1343  
ø max 42 cm H 45 cm  
Pø 15 cm  
2 x E14 x 40W



Art.1342  
ø max 50 cm  
H 172 cm  
Pø 15 cm  
2 x E14 x 40W



212

Art. 1290/G  
Pø 25 cm H 58 cm  
1 x E14 x 40W



Art. 1290/CH5/BIS  
ø max 80 cm H 50 cm  
Pø 16 cm  
5 x E14 x 40W

*Lampadario con sfere in vetro  
di Murano ambra, paralume in  
chiffon avorio su fodera gialla.*

213





Art. 1068  
ø max 40 cm H 35 cm  
Pø 12 cm  
2 x E14 x 40W



Art. 1199  
ø max 50 cm H 195 cm  
Pø 16 cm  
6 x E14 x 40W



Art. 926/CH10  
ø max 100 cm H 80 cm  
Pø 16 cm  
10 x E14 x 40W





Art.1162/OVAM  
P ovale 60 cm H 185 cm  
2 x E27 x 60W



Art.1237  
ø max 70 cm H 50 cm  
Pø 16 cm  
6 x E14 x 40W





*Paralume  
in organza  
stropicciata viola e  
fodera avorio.*

Art. 1468  
Pø 55 cm H 180 cm  
2 x E27 x 60W  
Nappa N. 33

*Lampadario in tubo  
diamantato ottone lucido con  
piattini di cristallo e pendenti  
di Swarovski, paralume in  
pizzo con paillettes marroni e  
fodera in seta avorio.*

Chandelier made of a special diamond cut of polished brass tube, with crystal Swarovski saucers and pendants, lampshade in brown lace with brown paillettes embroidered and ivory silk.

Люстра из хромированных трубок с алмазной обработкой, с хрустальными дисками и подвесками из Swarovski, абажур из шелка цвета слоновой кости с кружевами.

Art. 1451/CH32  
ø 190 cm H 185 cm  
32 x E14 x 40W





Art. 1505/CH5/LU  
Ø 75 cm H 90 cm  
Pø 16 cm  
5 x E14 x 40W



*Lampada con tubo  
diamantato in ottone oro  
vecchio e inserti Swarovski.*

*Paralume plissé avorio e  
bordo Swarovski ambra.*



Art. 1443/G  
Pø 35 cm H 75 cm  
1 x E27 x 60W

Art. 1443/P  
Pø 22 cm H 43 cm  
1 x E14 x 40W



Art. 1451/BIS  
 ø 148 cm H 120 cm  
 20 x E14 x 40W



Art. 1505/CH4  
 ø 75 cm H 60 cm  
 Pø 16 cm  
 4 x E14 x 40W

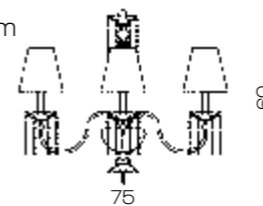

Art. 1506/CH8  
 ø 109 cm H 68 cm  
 Pø 16 cm  
 8 x E14 x 40W

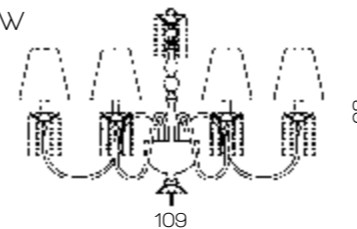

Art. 1507/CH8  
 ø 148 cm H 82 cm  
 Pø 18 cm  
 8 x E14 x 40W

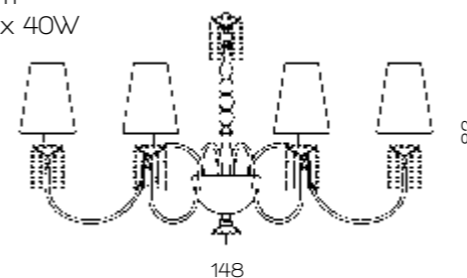

Art. 1508/CH12  
 ø 190 cm H 120 cm  
 Pø 20 cm  
 12 x E14 x 40W

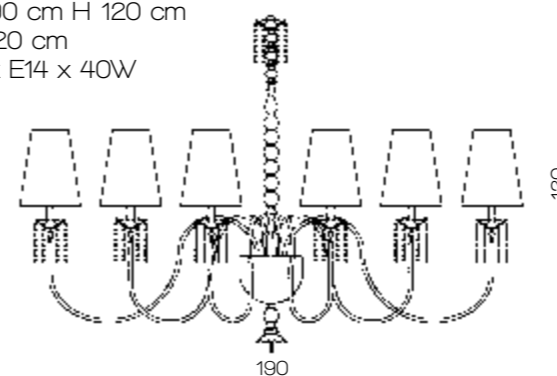

Art. 1451/CH32  
 ø 190 cm H 185 cm  
 32 x E14 x 40W

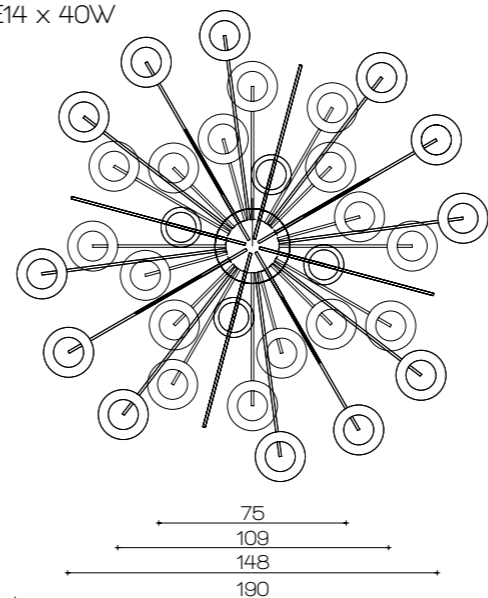

*Lampadario in tubo  
 diamantato eromato con  
 piattini di cristallo e pendenti di  
 Swarovski, paralume in seta  
 pura lucida grigio antracite su  
 fodera grigia.*

Chandelier made of a special diamond cut of chrome brass tube, with crystal Swarovski saucers and pendants, lampshade in shining gray silk on gray lining.

Люстра из хромированных трубок с хрустальными блюдцами и подвесками из Swarovski, абажур из блестящей шелковой ткани с серой подкладкой.

Art. 1451/A2 KR  
 ø 58 cm H 40 cm  
 Sp 30 cm Pø 16 cm  
 2 x E14 x 40W

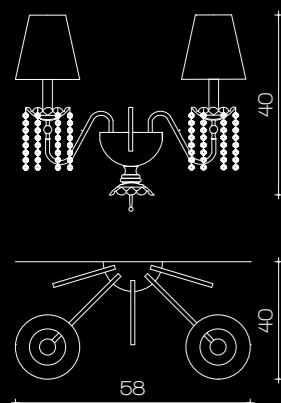

Art. 1451/FL/KR  
 ø 68 cm H 192 cm  
 Pø 16 cm  
 3 x E14 x 40W







*Lampadario con tube  
diamantato in ottone  
e piattini di cristallo  
Swarovski, paralume in  
pieghe seta pura lucida avorio.*

Art. 1452/CH8  
ø 110 cm H 70 cm  
Pø 18 cm  
8 x E14 x 40W

225



Il Paralume Marina



Art. 1339  
Pø 45 cm H 80 cm  
1 x E27 x 60W



Art.1424/G  
H 60 cm Pø 25 cm  
1 x E14 x 60W

Art.1424/P  
H 40 cm Pø 20 cm  
1 x E14 x 40W



*Plafoniera in ottone cromato  
con file di perle in pasta di  
vetro, paralume in tessuto  
dedar con motivo di coccoodrillo  
stampato avorio.*

Chandelier on chrome brass with pearls of  
paste's Murano glass, lampshade in Dedar  
pressed cocrodile ivory tissue.

Люстра из хромированной латуни с  
шариками из стеклянной пасты, абажур  
из ткани Dedar с темой крокодила цвета  
слоновой кости.

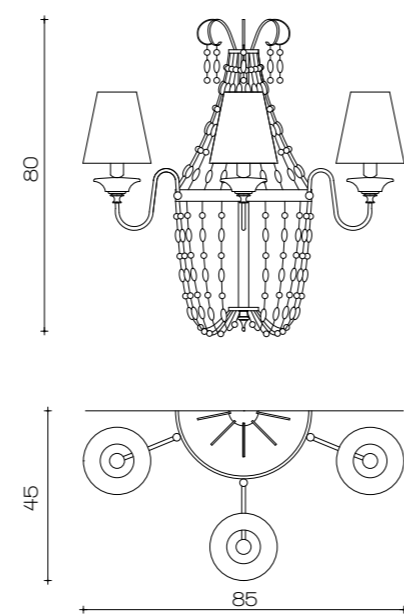

Art. 1380/A3  
ø 85 cm H 80 cm Pø 18 cm  
3 x E14 x 40W

Art. 1380/B1  
ø 100 cm H 105 cm Pø 18 cm  
8 x E14 x 40W



229

Il Paralume Marina

Art. 1445  
ø 50 cm H 38 cm  
4 x E14 x 40W



*Sospensione con pendenti  
in vetro di Murano,  
paralume in chiffon avorio  
con Swarovski su federa  
gialla.*

Art. 1498  
ø 68 cm H 80 cm  
Pø 16 cm  
4 x E14 x 40W



Art. 1444  
ø 30 cm H 50 cm  
2 x E14 x 40W

*Lampada con file di perle in:  
pasta di vetro - sfere di ottone  
Swarovski infilate a mano,  
paralume in chiffon avorio  
esterno su federa seta avorio.*

Art. 1458  
Pø 43 cm H 84 cm  
1 x E27 x 60W





232

Art. TL132  
ø 50 cm H 80 cm  
1x E27x 60W



Art. TL130 ambra  
ø 38 cm H 82 cm  
3xE14x25W

Art. TL130 ametista  
ø 38 cm H 82 cm  
3xE14x25W

233



Art. 1607/CH5  
ø 80 cm H 50 cm  
Pø 16 cm  
5 x E14 x 40W



Art. 1607/FL  
Pø 56 cm H 180 cm  
3 x E14 x 40W

Art. 1607/A2  
ø 65 cm H 50 cm  
Pø 16 cm  
2 x E14 x 40W



Art. 1585/P  
Pø 33 cm H 64 cm  
1 x E27 x 40W

Art. 1585/G  
Pø 40 cm H 88 cm  
1 x E27 x 60W





*Collezione ricca di passione ed esperienza, è legata al lampadario in ottone finito in oro vecchio e incastonati uno ad uno cristalli rossi Swarovski Elements. Paralume dai motivi floreali bordeaux in un velo di organza nera devorè cucito su una fodera di seta avorio. Full made in Italy.*

Art. 1460/CH5  
 ø 76 cm H 40 cm Pø 16 cm  
 5 x E14 x 40W

The center of this collection, full of passion and experience, is the chandelier made of brass in old gold colour cover and red inserts embedded one by one. The lampshades with bordeaux floral patterns on the veil of black organza devorè are sewn on the top of ivory silk lining. Full made in Italy.

**В эту коллекцию мастера вложили свой опыт и свою страсть. Все ее изделия сочетаются с люстрой цвета состаренного золота с красными кристаллами Swarovski Elements, тщательно прикрепленными по одному. Абажуры пошиты на шелковой подкладке цвета слоновой кости изнутри и тонкого слоя черной органзы с бордовыми цветочными композициями снаружи. Full made in Italy.**



Art.1612  
 H 78 cm Pø 44 cm  
 2 x E14 x 40W



Art. 1460/FL  
 Pø 55 cm H 180 cm  
 2 x E27 x 60W  
 Nappa N. 10

Art. 1875/G  
 Pø 35 cm H 70 cm  
 1 x E27 x 60W  
 Nappa N. 30

Art. 1875/P  
 Pø 16 cm H 56 cm  
 1 x E14 x 40W



Art. 1460/A1  
 Sp 28 cm H 33 cm  
 Pø 16 cm  
 1 x E14 x 40W

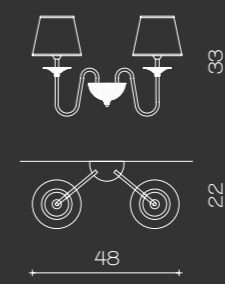

Art. 1460/A2  
 L 48cm H 33 cm  
 Sp 22 cm Pø 16 cm  
 2 x E14 x 40W

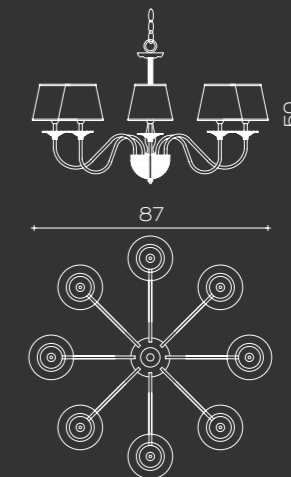

Art. 1460/CH8  
 ø 87 cm H 50 cm  
 Pø 16 cm  
 8 x E14 x 40W

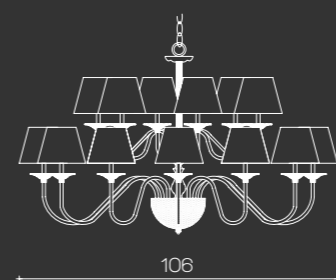

Art. 1460/CH18  
 ø 106 cm H 64 cm  
 Pø 16 cm  
 18 x E14 x 40W

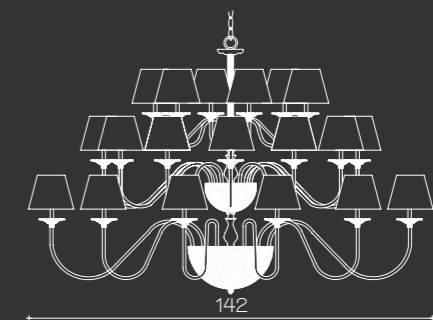

Art. 1460/CH30  
 ø 142 cm H 90 cm  
 Pø 16 cm  
 30 x E14 x 40W





*Chiffon con Swarovski*



Art. 1267/P/OVAM  
Pø 18 cm H 47 cm  
1 x 40W x E14

Art. 1267/G/OVAM  
Pø 30 cm H 51 cm  
1 x E27 x 60W

Art. 1315/OV/AM  
H 75 cm ø 90 cm  
5 x E14 x 40W



Art. 1314/OVAM  
Pø 60 cm H 190 cm  
2 x E27 x 60W





Art. 1314/KR  
ø 60 cm H 190 cm  
2 x E27 x 60W



Art.1315/KR  
H 75 cm ø 90 cm  
5 x E14 x 40W



Art. 1316/KR  
ø 18 cm H 40 cm  
1 x E14 x 40W



Art. 1267G/KR  
ø 30 cm H 51 cm  
1 x E27 x 60W

Art.1267P/KR  
ø 18 cm H 47 cm  
1 x E14 x 40W



Art.1325  
Pø 55 cm H 172 cm  
3 x E14 x 40W



Art. 1325/CH6  
ø max 84 cm H 80 cm  
Pø 16 cm  
6 x E14 x 40W

*Scheggia di cristallo Fiorentino*





Art.1324/M  
Pø 22 cm H 52 cm  
1 x E14 x 40W

Art. 1325/A1  
Pø 16 cm H 40 cm  
Sp 23 cm  
1 x E14 x 40W



Art. 1025  
H 185 cm  
1 x E27 x 60W



Art.1324/P  
H 39 cm Pø 16 cm  
1 x E14 x 40W



Art.1324/G  
H 77 cm Pø 40 cm  
1 x E27 x 60W





*Lampadario con sfere in vetro  
di Murano ambra, paralume in  
chiffon avorio su federa gialla.*

Art. 846/CH16  
ø 150 cm H 110 cm  
Fø 18 cm  
16 x E14 x 40W

Art. 873  
ø 52 cm H 50 cm  
2 x E14 x 40W

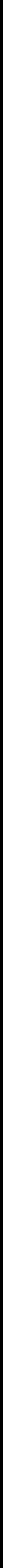

Art.872  
H 170 cm ø 45 cm  
3 x E14 x 40W

249



Il Padrone Marina

Art. 846/A1  
ø 14 cm H 39 cm  
1 x E14 x 40W



Art. 846/A  
ø 50 cm H 45 cm  
2 x E14 x 40W



Art.846/P  
ø 55 cm H 50 cm  
4 x E14 x 40W





Art. 846  
ø 90 cm H 80 cm  
Pø 16 cm  
8 x E14 x 40W



Art. 853/P  
ø 25 cm H 43 cm  
1 x E14 x 40W



Art. 853/G  
H 67 cm ø 45 cm  
1 x E27 x 60W





Art.868  
ø 55 cm H 183 cm  
2 x E27 x 60W



Art.869  
ø 40 cm H 180 cm  
1 x E27 x 100W



Art.838  
ø 80 cm H 50 cm  
6 x E14 x 40W







Art. 709/G  
ø 66 cm H 58 cm  
Pø 16 cm  
5 x E14 x 40W



Art. 922/P  
ø 26 cm H 57 cm  
1 x E14 x 40W

Art. 922/G  
ø 35 cm H 77 cm  
1 x E27 x 60W



258

Art. 1287/G  
Pø 35 cm H 62 cm  
1 x E27 x 60W

Art. 1287/P  
Pø 25 cm H 46 cm  
1 x E14 x 40W

Art. 1249  
Pø 55 cm  
H 178 cm  
2 x E27 x 60W



259

Art. 1287/CH6  
H 80 cm max 75 cm  
Pø 16 cm  
6 x E14 x 40W





Art.1292  
Pø 55 cm H 163 cm  
4 x E14 x 40W



Art.1292/A Pø 14 cm  
ø max 35 cm H 35 cm  
2 x E14 x 40W



Art.1317  
Pø 25 cm H 60 cm  
1 x E14 x 40W



Art.1292/CH5  
ø max 55 cm H 55 cm  
Pø 14 cm  
5 x E14 x 40W



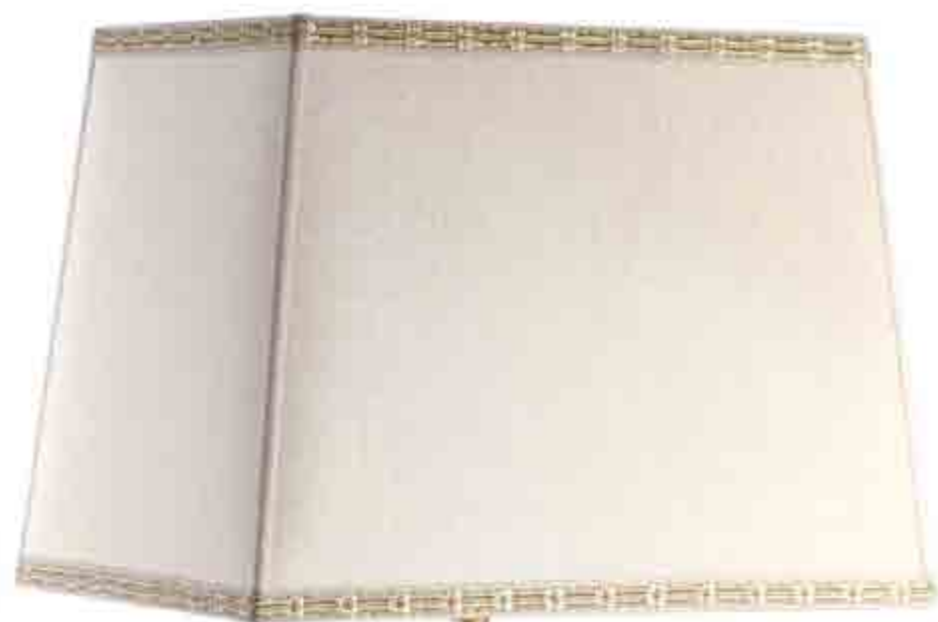

Art. 1636  
L 40 cm H 60 cm Sp 22 cm  
1 x E27 x 60W

Art. 1638  
L 32 cm H 29 cm

Art. 1637  
L 31 cm H 58 cm Sp 22 cm  
1 x E27 x 60W

Art.1602/CH3  
L 140 H 100 cm Pø 30 cm  
2 x E14 x 40W  
1 x Dicroica



Art. 1602  
Pø 38 cm H 68 cm  
1 x E27 x 60W



Art. 1602/FL  
Pø 50 cm H 180 cm  
1 x E27 x 60W



Art.1848  
Pø 50 cm H 94 cm  
1 x E27 x 60W  
Nappa N. 15



*Lampada in cristallo fiorentino  
24 % piombo con incisioni fiori,  
paralume seta plissé su seta avorio.*



Art. 1632  
Pø 50 cm H 96 cm  
1 x E27 x 60W



Art. 1250  
ø max 30 cm  
H 60 cm  
Candles not included



Art.1747/G/OV  
Pø 45 cm H 76 cm  
1 x E27 x 60W  
Nappa N. 30 Bianca e Oro

Art.1747/P/OV  
Pø 33 cm H 56 cm  
1 x E27 x 60W  
Nappa N. 30 Bianca e Oro



Art.1746/G/KR  
Pø 45 cm H 76 cm  
1 x E27 x 60W  
Nappa N. 10 Argento

Art.1746/P/KR  
Pø 33 cm H 56 cm  
1 x E27 x 60W  
Nappa N. 10 Argento





Art. TL 63/CG Bianca  
Pø 45 cm H 80 cm  
1 x E27 x 60W



Art. 1873/G  
Pø 45 cm H 80 cm  
1 x E27 x 60W

Art. 1873/P  
Pø 35 cm H 60 cm  
1 x E27 x 60W





Art.1902/P  
Pø 35 cm H 63 cm  
1 x E27 x 60W

Art.1902/G  
Pø 45 cm H 85 cm  
1 x E27 x 60W



Art.1324G/KR  
Pø 40 cm H 77 cm  
1 x E27 x 60W  
Nappa N. 17 Argento



Lampada in cristallo  
colore viola, base e  
capitello in ottone lucido  
con paralume in seta  
organza arricciata.

Art.1396  
Pø 45 cm H 70 cm  
1 x E14 x 60W  
Nappa N. 32



Lampada in cristallo colore  
rosso, base e capitello in  
ottone lucido con paralume  
con paillettes rosse  
su fodera avorio.

Art.1568  
Pø 45 cm H 70 cm  
1 x E27 x 60W  
Nappa N. 1 Rossa



Art.1568/P  
Pø 45 cm H 64 cm  
1 x E27 x 40W



Art.1595/A1  
L 13 cm H 26 cm  
Sp 10 cm  
1 x E27 x 60W



Art.1595/P  
L 13x13 cm H 26 cm1  
x E27 x 60W

Paralume rettangolare in organza  
oro su fodera avorio.

Art.1595/G  
PL 46x24 cm H 73 cm  
1 x E27 x 60W





*Lampada in cristallo  
fiorentino 24% piombo  
molata a mano.*

*Doppia accensione,  
paralume in seta gialla su  
fodera gialla.*

Art. 1596  
Pø 45 cm H 85 cm  
1 x E27 x 60W  
1 x E14 x 40W (interna)



279



Il Paralume Marina



Art.860  
ø 30 cm H 190 cm  
1 x E27 x 60W



*Paralume plissé in chiffon  
giallo foderato in seta gialla  
e cucito a mano. Cristallo  
fiorentino soffiato, temperato e  
molato a mano, fusione in terra  
d'ottone*

Art.TL57  
ø 45 cm H 80 cm  
1 x E27 x 60W  
1 x E14 x 40W (interna)





*Cristallo fiorentino soffiato, temperato e molato a mano. Paralume in seta pura ambra federato in seta avorio cucito a mano*

Art.TL53  
Pø 50 cm H 88 cm  
1 x E27 x 60W

282



Art.TL33  
Pø 45 cm H 80 cm  
1 x E27 x 60W

Art.TL33C  
Pø 45 cm H 80 cm  
1 x E27 x 60W

283

Il Paralume Marina





Art.885 Blu  
ø 38 cm H 75 cm  
1 x E27 x 60W



Art.TL86  
ø 45 cm H 80 cm  
1 x E27 x 60W





Art.TL87  
ø 45 cm H 80 cm  
1 x E27 x 60W



Art.358/F  
ø 45 cm H 80 cm  
1 x E27 x 60W







Art.1306/P/OVAM  
Pø 44 x 31 cm H 74 cm  
1 x E27 x 60W



Art.1306/G/OVAM  
Pø 50x34 cm H 88 cm  
1 x E27 x 60W



Art:1306/G/OVTR  
Pø 45 cm H 88 cm  
1 x E27 x 60W  
Nappa N. 1 strass Marrone/Oro

Art:1306/P/OVTR  
ø 40 cm H 74 cm  
1 x E27 x 60W  
Nappa N. 1 strass Marrone/Oro



Art:1897/G  
Pø 45 cm H 88 cm  
1 x E27 x 60W  
Nappa N.48





Art.480  
 H 75 cm  
 Pø 45 cm  
 1 x E27 x 60W



Art.790  
 H 60 cm  
 Pø 33 cm  
 1 x E27 x 60W

Art.789  
 H 80 cm  
 Pø 45 cm  
 1 x E27 x 60W



*Lampada in cristallo fiorentino melato  
a mano, paralume a sottana chiffon lilla e  
ricamo originale in perle avorio.*

Art.1373/G  
Pø 40 cm H 70 cm  
1 x E27 x 60W  
Nappa N. 10

Art.1373/P  
Pø 32 cm H 54 cm  
1 x E14 x 40W



Art. TL111  
Pd 40cm H 70cm  
1 x E27 x 60W



Art.361  
Pø 45 cm  
H tot. 75 cm  
1 x E27 x 60W



Art.358  
Pø 45 cm H 80 cm  
1 x E27 x 60W



Art.359  
H 60 cm  
Pø 33 cm  
1 x E27 x 60W





Lampada in cristallo fiorentino molato a mano, paralume a sottana in pizzo avorio e bordo oro.

Art.1544  
Pø 43 cm H 70 cm  
1 x E27 x 60W



Lampada in cristallo fiorentino molato a mano, paralume a sottana chiffon bordeaux e ricamo in Swarovski.

Art.1545  
Pø 43 cm H 70 cm  
1 x E27 x 60W





Art.TL42  
 Pø 40 cm H 75 cm  
 1 x E27 x 60W



Art.360  
 Pø 45 cm H tot. 80 cm  
 1 x E27 x 60W



Art.525  
Sp 25 cm Pø 30 cm  
H tot. 40 cm  
1 x E14 x 40W



Art.523  
P 25 cm Pø 40 cm  
H tot. 160 cm  
1 x E27 x 60W

Art.524  
Pø 37 cm  
H tot. 58 cm  
1 x E27 x 60W



Art.867  
ø 33 cm H 54 cm  
1 x E27 x 60W

Art.870  
ø 28 cm H 43 cm  
1 x E27 x 60W







304

Art.570  
 Pø 40 cm H tot. 70 cm  
 3 x E14 x 40W

Art.570/C  
 Candles not included

Art.560  
 Pø 25 cm H tot. 45 cm  
 1 x E14 x 40W



305

Art.856/M  
 ø 25 cm H 47 cm  
 1 x E14 x 40W

Art.856/P  
 ø 20 cm H 36 cm  
 1 x E14 x 40W

Art.856/G  
 ø 30 cm H 56 cm  
 1 x E27 x 60W



Art.358/AM  
Pø 40 cm H 66 cm  
1 x E27 x 60W  
Cristallo Ambra



Art.358/GR/BX  
Pø 40 cm H 66 cm  
1 x E27 x 60W  
Cristallo Grigio

Art.358 NR/NR  
Pø 40 cm H 66 cm  
1 x E27 x 60W  
Cristallo Nero

Art.358 TR/RO  
Pø 40 cm H 66 cm  
1 x E27 x 60W  
Cristallo Trasparente





Art.1854  
Pø 45 cm H 89 cm  
1 x E27 x 60W  
Nappa N. 10 ORO



Art.1846  
Pø 48 x 35 cm H 83 cm  
1 x E27 x 60W  
Nappa N. 10 ORO





Art.1811/FL/KR  
Ø 55 cm H 185 cm  
3 x E27 x 60W



Art.1847  
PØ 45 cm H 86 cm  
1 x E27 x 60W  
Nappa N. 42





*Lampada  
in vetro di  
Murano,  
paralume in  
chiffon avorio  
plissé.*

Art.935/P  
Pø 40 cm H 68 cm  
1 x E27 x 60W



Art.1531  
Pø 50 cm H 78 cm  
1 x E27 x 60W  
Nappa N. 17



314

Art.929/V  
ø 14 cm H 40 cm

Art.929  
ø 45 cm H 84 cm  
1 x E27 x 60W



315

Il Parlame Marina

Art.935  
ø 50 cm H 78 cm  
1 x E27 x 60W



316

Art.943  
ø 28 cm H 193 cm  
1 x E27 x 60W



317

Il Paralume Marina

Art.977/C  
ø 8 cm H 17 cm

Art.977/P  
ø 8 cm H 10 cm

Art.977/M  
ø 8 cm H 12 cm

Art.956  
ø 26 cm H 47 cm



Art.936/BIS  
Pø 50 cm H 78 cm  
1 x E27 x 60W



Art.957/G  
ø 30 cm H 44 cm

Art.936  
ø 50 cm H 78 cm  
1 x E27 x 60W

Art.957/P  
ø 50 cm H 78 cm





Art.1233/P  
 Pø 33 cm H 60 cm  
 1 x E27 x 60W

Art.1233/M  
 Pø 45 cm H 75 cm  
 1 x E27 x 60W

*Vetro soffiato di Murano lavorazione "Margherita"*



Art.1233/V  
 ø 40 cm H 35 cm

Art.1233/Z  
 ø 30 cm H 50 cm



Art.1293/G  
 Pø 45 cm H 110 cm  
 1 x E27 x 60W





Art.926/G Cromo  
Pø 40 cm H 75 cm  
1 x E27 x 60W



Art.1008  
Pø 40 cm H 75 cm  
1 x E27 x 60W





Art.934/MRO  
Pø 35 cm H 55 cm  
1 x E27 x 60W



Art.934/G  
Pø 45 cm H 81 cm  
1 x E27 x 60W





326

Art.TL1PP  
H 52 cm  
Pø 26 cm  
1 x E14 x 40W  
Nappa Fascetta

Art.TL1  
H 80 cm  
Pø 45 cm  
1 x E27 x 60W  
Nappa N.1 Marrone oro

Art.TL1P  
H 68 cm  
Pø 35 cm  
1 x E27 x 60W  
Nappa Fascetta



327

Art.TL1  
H 80 cm  
Pø 45 cm  
1 x E27 x 60W



Art.TL1R  
 Pø 45 cm H tot. 77 cm  
 x E27 x 60W  
 Nappa Grossa

Art.TL1 PICCOLA ORO  
 Pø 33 cm H tot. 58 cm  
 1 x E27 x 60W  
 Nappa Semplice



Art:875  
 ø 45 cm H 85 cm  
 1 x E27 x 60W  
 Nappa Grossa



*Lampada in vetro di murano soffiata a bocca ambra. Paralume in chiffon avorio con federa in seta gialla bordo barocco ambra/oro*



Art.748  
H 55 cm Pø 33 cm  
1 x E27 x 60W  
Nappa Pon Pon

Art.747  
H 77 cm Pø 45 cm  
1 x E27 x 60W  
Nappa Pon Pon

*Paralume in chiffon avorio foderato in seta gialla con bordo oro-barocco vetro di murano soffiato a bocca ambra e oro. Fusione artigianale in terra, eseguita su stampi colata a mano*



Art.TL12  
H 52 cm Pø 30 cm  
1 x E27 x 60W  
Nappa semplice oro

Art.TL13  
H 75 cm P. ovale 40 cm  
1 x E27 x 60W  
Nappa Pon Pon





Art.574/B  
H min 150 cm  
max 180 cm  
Pø 35 cm  
1 x E27 x 60W



Art.701  
H 105 cm ø 45 cm  
1 x E27 x 60W



Art.702  
H 45 cm ø 22 cm  
1 x E14 x 40W

Art.638P  
H 46 cm Pø 29 cm  
1 x E14 x 40W



Art.TL2P  
H 41 cm Pø 25 cm  
1 x E14 x 40W



Art.445P  
H 57 cm Pø 25 cm  
1 x E14 x 40W





334

Art.150  
H 59 cm P quadro 33x24 cm  
2 x E14x 40W

Art.603  
H 70 cm Pø 30 cm  
1 x E27 x 60W

Art.756P  
H 39 cm Pø 26 cm  
1 x E14x 40W



Art.905  
H 35 cm ø 33 cm  
ventola ø 11 cm  
2 x E14x 25W



Art.861  
H 42 cm  
L27 cm  
1 x E27 x 25W



Art.638/A  
H 50 cm ø 30 cm  
2 x E14x 25W



335

Art.862  
Pd 50cm H 180cm  
2 x E27 x 60W





Art.TL2  
H tot. 80 cm  
Pø 48 cm  
1 x E27 x 60W

Art.TL3  
H tot. 170 cm  
Pø 55 cm  
1 x E27 x 60W

Art.606  
H 55 cm  
Pø 40 cm



Art.614  
H tot. 55 cm  
Pø 44 cm  
3 x E14 x 40W

Art.516 R  
H tot. 160 cm  
Pø 40 cm  
1 x E27 x 60W

Art. 617  
H tot. 43 cm Pø 20 cm  
1 x E14 x 40W





Art.1330/P/OVRS  
H 50 cm P ovale ø 28 cm  
1 x E14 x 40W

Art.1330 M/OVRS  
H 65 cm P ovale ø 35 cm  
1 x E27 x 60W



338

Art.1330/P/OVTO  
H 50 cm P ovale ø 28 cm  
1 x E14 x 40W

Art.1330 M/OVAM  
H 65 cm P ovale ø 35 cm  
1 x E27 x 60W



Art.1358  
H 180 cm P ø 55 cm  
1 x E27 x 60W



340

Art.953/BIS  
H 182 cm ø 50 cm  
2 x E27 x 60W



341

Art.926/G  
H 77 cm ø 40 cm  
1 x E27 x 60W

Art.926/P  
H 49 cm ø 25 cm  
2 x E14 x 40W

Il Paralume Marina 



Art.969  
H 88 cm ø 45 cm  
3 x E14 x 40W

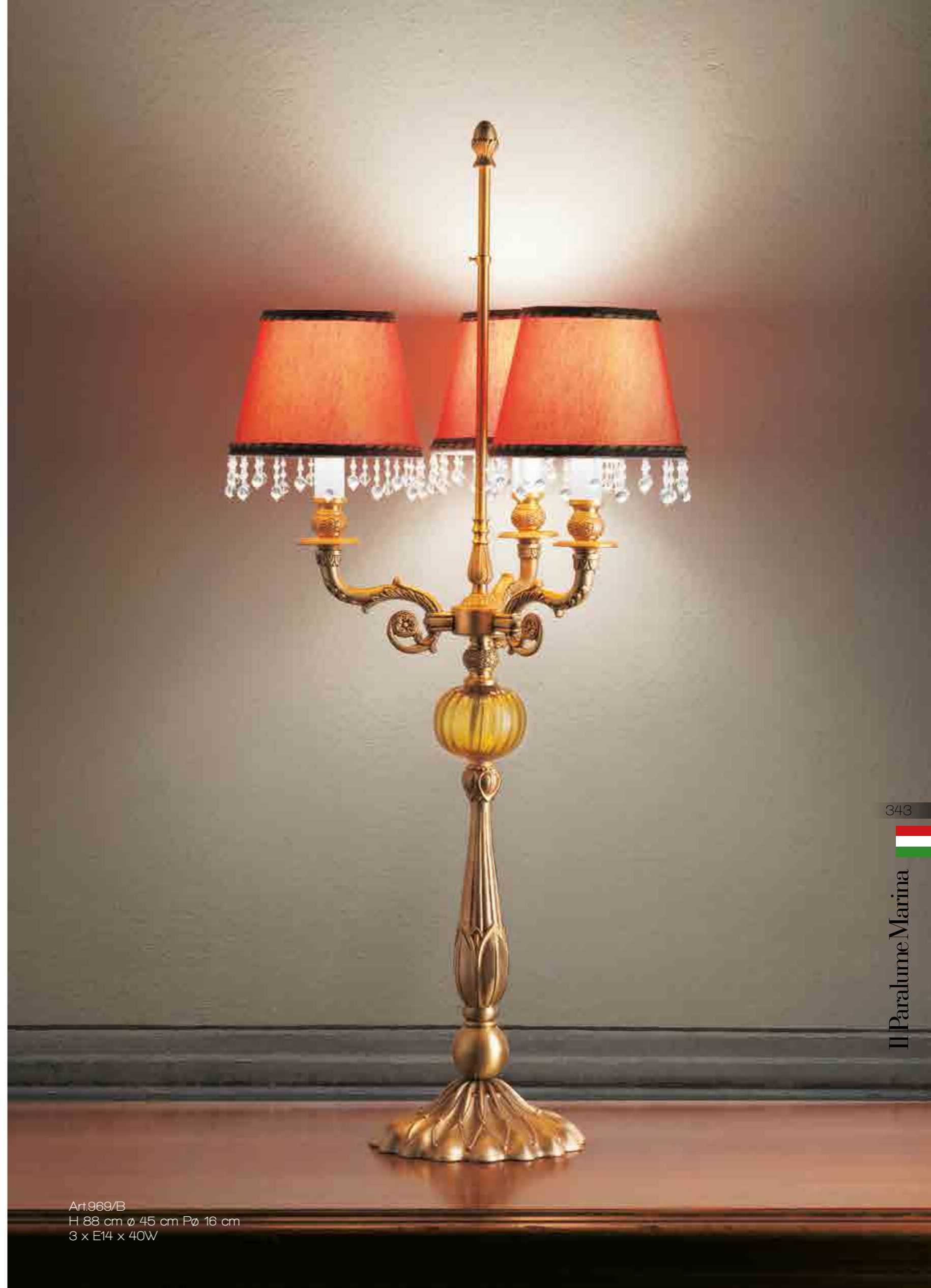

Art.969/B  
H 88 cm ø 45 cm Pø 16 cm  
3 x E14 x 40W



Art.TL68  
H 68 cm ø 50 cm  
3 x E14 x 40W



Art.TL63  
H 78 cm ø 40 cm  
1 x E27 x 60W  
Nappa N.1 Oro



Art.644  
H 67 cm ø 40 cm  
3 x E14 x 40W



Art.644/A  
H 60 cm ø 35 cm  
P 19 cm  
2 x E14 x 40W



Art.633  
H 56 cm ø 35x17 cm  
2 x E14 x 40W



Art.827  
H 90 cm ø 46 cm  
3 x E14 x 40W





348

Art.911  
H 47 cm ø 15 cm  
1 x E14 x 40W

Art.912  
H 55 cm ø 18 cm  
1 x E27 x 40W



Art.910  
H 160 cm ø 25 cm  
estensione max  
braccio 38 cm  
1 x E27 x 60W



Pinella  
di  
Marta

Art.109  
H tot. 80 cm  
L 49 cm P 31 cm  
Pø 45 cm  
1 x E27 x 60W



Art.314  
H tot. 53 cm  
Pø 40 cm ø base 25 cm  
2 x E27 x 60W



Art.312  
H tot. 46 cm L 30 cm  
ø base 25 cm  
1 x E27 x 60W



Art.313  
H 45 cm P 22x14 cm  
ø base 25 cm  
1 x E27 x 60W



Art.108  
H tot. 65 cm  
Pø 40 cm  
1 x E27 x 60W

Art.266  
H 38 cm  
Pø 25 cm  
1 x E14 x 40W

Art.107  
H 52 cm  
Pø 25 cm  
1 x E27 x 60W





Art. 771  
Pø 25 cm  
H 78 cm  
1 x E14 x 40W

Art. 770  
Pø 35 cm  
H 170 cm  
1 x E27 x 60W



Lamp on  
Lamp off



Art.1433/KR  
H 50 cm L 38 cm  
1 x E27 x 60W



Art.1433/BI  
H 50 cm L 38 cm  
1 x E27 x 60W





Art. 184  
H tot. 180 cm  
Pø 45 cm  
Sp max 50 cm  
1 x E27 x 60W



Art. 182  
H tot. 163 cm  
Pø 50 cm 1 x E27 x 60W



Lampshade open in back.  
Ventola aperta dietro.

Art. 515  
H tot. 180 cm Pø 60 cm  
1 x E27 x 60W



Art. 426  
H tot. 170 cm  
Pø 50 cm  
1 x E27 x 60W





Art.516  
H tot. 160 cm  
Pø 40 cm  
1 x E27 x 60W



Art.331  
H tot. 160 cm  
Pø 30 cm  
1 x E27 x 60W



Art.443  
H tot. 165 cm  
Pø 40 cm  
1 x E27 x 60W



Art.967  
H 184 cm ø 60 cm  
3 x E14 x 40W  
Nappa N.1 marrone oro

356

357

Il Paralume Marina





Art.845  
H 190 cm Ø 60 cm  
2 x E27 x 60W



Piantana oro vecchio  
modello bridge da lettura,  
paralume in seta pura  
ricamata e foderata avorio.

Art.124/BIS  
H 180 cm PØ 47 cm  
1 x E27 x 60W





Art.1461/BI  
H 180 cm Pø 50 cm  
2 x E14 x 60W  
Nappa N. 1  
marrone-oro  
2 x E27 x 60W

*Piantana in fusione  
di ottone laccata avorio,  
paralume in pizzo e  
piume marroni su  
federa avorio.*

Floor lamp in ivory brass  
lacquered, lampshade  
made of brown lace and  
plume on a ivory lining,  
string in Murano brown and  
gold hand-made pearls.

**Напольная лампа из плавки  
латуни лакированной  
цветом слоновой кости,  
абажур с кружевами  
и пухом коричневого  
цвета на подкладке цвета  
слоновой кости, шнурок из  
Муранского коричневого и  
золотого бисера.**

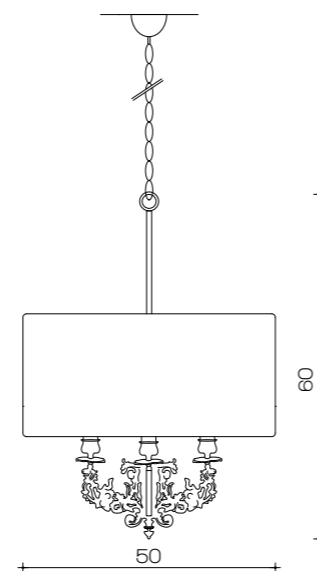

Art.1461/CH3/BI  
H 60 cm Pø 50 cm  
3 x E14 x 60W



Piantana in fusione di ottone oro  
vecchio e paralume dorato in  
seta pura devorè.

Art.1461/OV  
H 180 cm Pø 50 cm  
2 x E27 x 60W





Art.863  
H 210 cm  
1 x E27 x 60W



Art.TL25  
H 30 cm ø 21 cm  
P 18 cm  
1 x E14 x 40W

Art.TL23  
H 37 cm ø 28 cm  
1 x E27 x 100W



Art.909  
ø 28 cm H 45 cm  
paralume ø 11 cm  
2 x E14 x 25W



Art.420/B  
ø 47 cm H 44 cm  
3 x E14 x 40W





Art.421  
Pø 18 cm  
H tot. 52 cm  
1 x E14 x 40W



Art.420  
Pø 16 cm  
Ø 42 cm x H 42 cm  
3 x E14 x 40W



Art.422  
Pø 18 cm  
H tot. 52 cm  
Ø 40 x H 50 cm  
2 x E14 x 40W



Art.419  
Pø 60 cm  
H tot. 170 cm  
Oval 50 cm x 30 cm  
2 x E27 x 60W



Art.418  
Pø 45 cm  
H tot. 65 cm  
Oval 42 cm x 26 cm  
2 x E27 x 40W







Art.588/B  
 ø 43 cm H 37 cm  
 Pø 14 cm  
 2 x E14 x 40W



Art.973  
 ø 58 cm H 45 cm  
 Pø 16 cm  
 3 x E14 x 40W

Art.590/CH6  
 ø 70 cm H 50 cm  
 Pø 18 cm  
 6 x E14 x 40W



Art.588  
 H 137 cm  
 ø 36 cm Sp 17 cm  
 2 x E14 x 40W

Art.587  
 ø 23 cm Sp 16 cm  
 H 36 cm  
 1 x E27 x 40W

Art.586  
 Pø 30 cm  
 H 54 cm  
 1 x E27 x 40W

Art.585  
 Pø 17 cm  
 H 43 cm  
 1 x E14 x 40W

Art.589  
 Pø 50 cm  
 H 170 cm  
 3 x E14 x 40W





Art.567  
Pø 31 cm H 30 cm  
2 x E14 x 40W



Art.569/3  
H 55 cm  
Pø 35 cm  
3 x E14 x 40W



Art.569/2  
H 55 cm  
Pø 33 cm  
2 x E14 x 40W



Art.564  
Pø 50 cm H 170 cm  
4 x E14 x 40W

Art.565  
Pø 50 cm H 170 cm  
2 x E14 x 40W



Art.404  
Pø 25 cm Sp 25 cm  
H 12 cm  
1 x E27 x 40W

Art.432  
Pø 47 cm  
1 x E27 x 60W





Art.779  
Pø 48 cm  
H 170 cm  
3 x E14 x 40W



Art.778  
Oval  
54 cm x 37 cm  
H 175 cm  
2 x E14 x 40W



Art.707  
ø 20 cm H 45 cm  
Sp 12 cm  
1 x E14 x 25W

Art.709  
ø 74 cm  
5 x E14 x 40W

Art.705  
Oval 30 x 22 cm  
H 56 cm  
1 x E27 x 40W

Art.706  
Oval 25 cm  
x 18 cm  
H 42 cm  
1 x E14 x 40W

Art.708  
Oval  
54 cm x 37 cm  
H 166 cm  
2x E27 x 60W





Art.590/S  
Ø 78 cm H 45 cm  
6 x E14 x40W



Art.TL26  
Ø 105 x H 62 cm  
6x E14 x 40W



Art.633/3  
PØ 35 cm H 60 cm  
3 x E14 x 40W

Art.TL40  
PØ 55 cm  
H 175 cm  
2 x E27 x 60W





Art.543  
ø 38 cm H 33 cm Pø 11cm  
2 x E14 x 25W



Art.542  
ø 34 cm H 35 cm  
Pø 14 cm  
2 x E14 x 25W



Art.544  
ø 38 cm Pø 11cm H 34 cm  
2 x E14 x 25W



Art.464  
ø 30 cm H 20 cm  
1 x E27 x 60W



Art.466  
ø 30 cm H 25 cm  
1 x E27 x 60W



Art.520  
Pø 16 cm  
Ø 76 cm H 45 cm  
6x E14 x 40W



Art.521  
Pø 35 cm H 45 cm  
2x E14 x 40W





Art.592  
ø 40 cm Sp 12 cm  
H 38 cm  
1 x E27 x 40W



Art.615  
H 56 cm  
ø 31 cm Sp 15 cm  
1 x E27 x 40W



Art.594  
ø 34 cm Sp 12 cm  
H 52 cm  
2x E14 x 25W



Art.594/P  
ø 20 cm Sp 15 cm  
H 40 cm  
1 x E14 x 25W



Art.616  
H 40 cm  
Sp 15 cm ø 25 cm  
1 x E27 x 40W



Art.593  
Pø 16cm  
H 50 cm  
ø 60 cm Sp 27 cm  
3 x E14 x 25W

Art.613  
H 43 cm Pø 11cm  
ø 47 cm Sp 28 cm  
3 x E14 x 25W

Art.591  
H 46 cm  
Sp 11 cm ø 40 cm  
2x E14 x 25W



Art.651  
ø 60 cm H 42 cm  
Sp 11 cm  
4 x E14 x 25W



Art.625  
ø 30 cm H 50 cm  
Sp 14 cm  
2 x E14 x 25W



Art.627  
ø 18 cm H 38 cm  
1x E14 x 25W



Art.628  
ø 37 cm H 34 cm  
Sp 14 cm  
2x E14 x 25W



Art.1510  
L 36 cm H 62 cm  
4 x G9 x 25W



382

Art.TL46  
Pø 11cm L 50 cm  
H 65 cm  
4 x E14 x 25W



Art.1397/A2  
L 35 cm H 56 cm  
2 x E14 x 25W

*Appliques foglia  
oro con pendenti  
Swarovski, ventola  
in seta pura e ricamo  
Swarovski*

Art.1393/A3  
L 50 cm H 70 cm  
3 x E14 x 25W

383







Art.851  
 ø 133 cm H 93 cm  
 2 x E27 x 60W



Art.431/C  
 ø 55 cm H 38 cm  
 2 x E14 x 25 W



Art.554  
 ø 116 cm H 50 cm  
 Pø 16 cm  
 8 x E14 x 25W



Art.431/B  
 ø 42 cm H 42 cm  
 2 x E14 x 25W

Art.650  
ø 35 cm H 25 cm  
P 16 cm  
2 x E14 x 40W



Art.545  
ø 40 cm H 18 cm  
2 x E14 x 25W



Art.550  
ø 35 cm H 33 cm  
3 x E14 x 25W



386

Art.652  
ø 35 cm H 34 cm  
Sp 11 cm Pø 11 cm  
2 x E14 x 25W



387

Art.541  
ø 54 cm H 48 cm  
2 x E14 x 25W



Art.549  
ø 27 cm H 28 cm  
1 x E27 x 25W





Art.403  
ø 32 cm H 40 cm  
Pø 14 cm  
2 x E14 x 25W



Art.232  
ø 57 cm H 35 cm  
Pø 14 cm  
2 x E14 x 25W



Art.402  
ø 70 cm H 40 cm  
Pø 14 cm  
4 x E14 x 25W



Art.311  
ø 120 cm H 40 cm  
Pø 40 cm  
4 x E27 x 25W

Art.375  
Pø 23 cm  
1 x E27x 60W



Art.322  
H 43 cm ø 37 cm  
2 x E27 x 25W



Art.151  
H tot. 56 cm  
Pø 31 cm  
2 x E14 x 25W

Art.320  
H 30 cm ø 40 cm  
2 x E14 x 25W



Art.323  
H 27 cm ø 27 cm  
1 x E27x 25W



Art.324  
H 27 cm ø 27 cm  
1 x E27x 25W



Art.231  
H 40 cm ø 30 cm  
Pø 16 cm  
1 x E14 x 25W



Art.230  
H 70 cm ø 50 cm  
Pø 16 cm  
2 x E14 x 25W



Art.504  
H 70 cm ø 50 cm  
1 x E27 x 40W



Art.505  
H 70 cm ø 40 cm  
Pø 28 cm  
1 x E27 x 40W



Art.526  
H 20 cm Pø 28 cm  
L max 54 cm  
1 x E27 x 40W



Art.535  
H 30 cm ø 27 cm  
1 x E27 x 25W

Art.527  
H 18 cm Pø 27 cm  
Sp 18  
1 x E27 x 40W



Art.949  
H 42 cm ø 27 cm  
1 x E27 x 25W



Art.947  
H 46 cm ø 30 cm  
1 x E27 x 25W



Art.948  
H 37 cm ø 34 cm  
2 x E14 x 25W



Art.950  
H 49 cm ø 30 cm  
1 x E27 x 25W



Art.626  
H 40 cm ø 20 cm  
1 x E27 x 25W



Art.648  
H 38 cm ø 35 cm  
1 x E27 x 25W



Art.647  
H 24 cm ø 25 cm  
SP max 37  
1 x E14 x 25W



Art.346  
H 27 cm L 26 cm  
1 x E27 x 25W



Art.280  
H 35 cm L 18 cm  
1 x E27 x 25W

394



Art.759  
H 34 cm L 38 cm  
2 x E14 x 25W



Art.347  
H 47 cm L 25 cm  
1 x E27 x 25W



Art.324  
H 35 cm L 26 cm  
1 x E27 x 25W

395



Il Paralume Marina



Art.399  
H 40 cm ø 35 cm  
1 x E27 x 40W



Art.431  
H 38 cm L 30 cm  
Pø 12 cm  
2 x E27 x 25W



Art.407  
L 27 cm  
H 48 cm  
Sp 6 cm



Art.405  
L 27 cm H 30 cm  
Sp 10 cm



Art.406  
L 36 cm H 28 cm  
Sp 17 cm

396

397

Art.408  
H 55 cm ø 30 cm  
1 x E27 x 40W



Art.342/B  
 ø 80 cm H 38 cm  
 Pø 16 cm  
 6 x E14 x 40W



Art.975  
 ø 80 cm H 45 cm  
 Pø 16 cm  
 8 x E14 x 25W

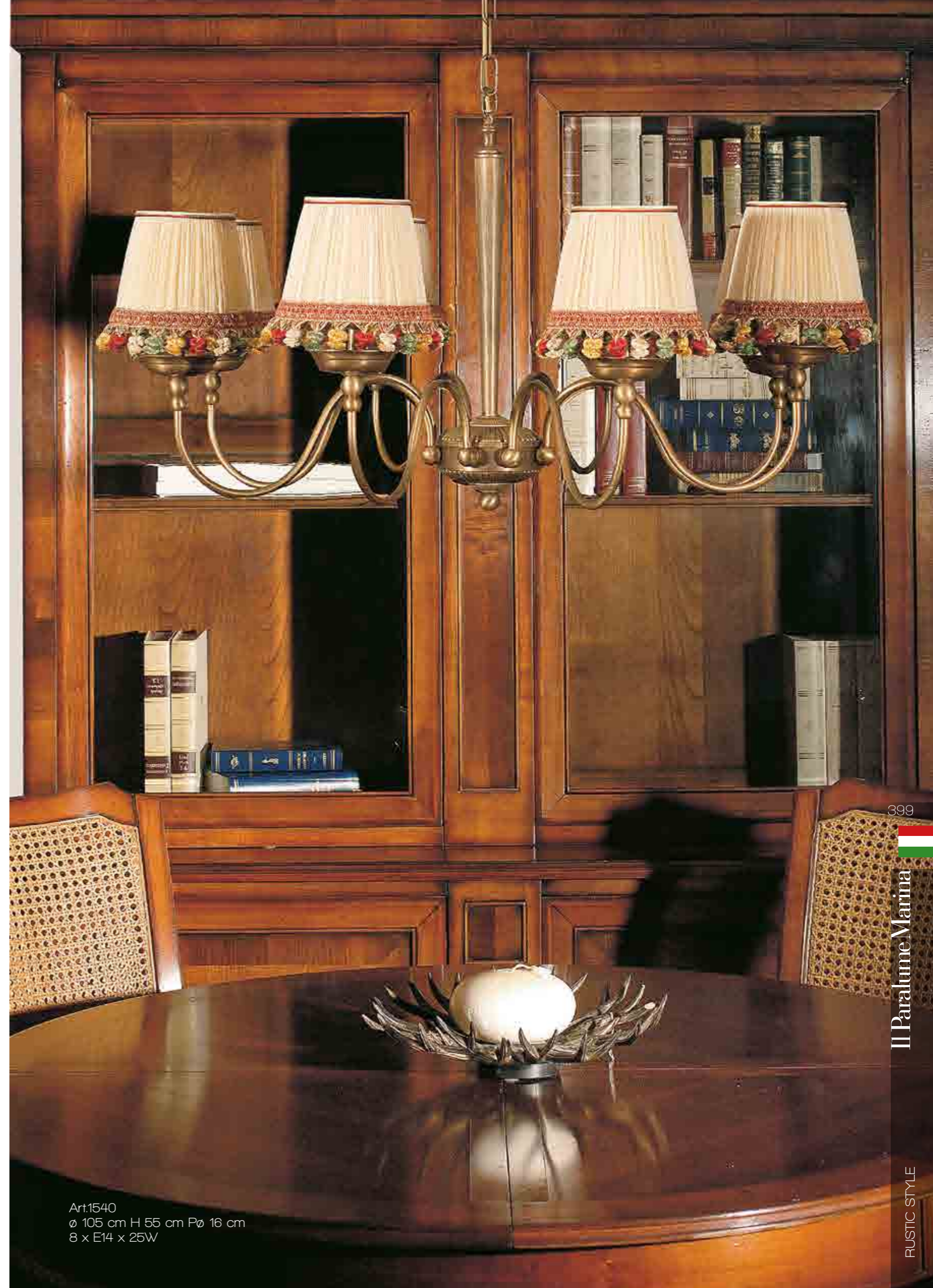

Art.1540  
 ø 105 cm H 55 cm Pø 16 cm  
 8 x E14 x 25W





Art.M21  
H tot. 175 cm ø 55 cm  
Nappa Grossa Oro  
2 x E27 x 60W



Art.512  
H tot. 135 cm  
H tot. 160 cm Pø 28 cm  
1 x E27 x 60W



Art.262 T  
H max 210 cm min 175 cm  
Tavolo ø 40 cm Pø 60 cm  
1 x E27 x 60W

Art.551  
Ø 66 cm x H 35 cm  
3 x E14 x 40W



Art.552  
Ø 76 cm H 35  
6 x E14 x 40W



Art.553  
Ø 86 x H 55 cm  
8 x E14 x 25W



Art.342/P1  
Ø76 cm x H 38 cm  
Pø 16 cm  
6 x E14 x 40W



Art.506  
H 35 cm  
ø 27 cm  
1 x E27 x 25W



Art.534  
H 46 cm  
ø 34 cm  
2 x E14 x 40W

Art.507  
Pø 26 cm H tot. 32 cm  
1 x E27 x 25W



Art.508  
Pø 38 cm H tot. 45 cm  
1 x E27 x 40W



Art.902  
 ø 37 cm H 90 cm  
 1 x E27 x60W

Art.903  
 ø 37 cm H 90 cm  
 1 x E27 x60W



Art.463  
 ø 50 cm  
 1 x E27 x60W



Art.465  
 Pø 30 cm H tot. 20 cm Sp 20 cm  
 1 x E27 x 60W



Art.483/L  
 H tot. 180 cm  
 ø 50 cm  
 1 x E27 x60W





406



407



Il Paralume Marina

Art. 2041/CH5/KR  
L 290 cm ø 48 cm H 110 cm  
5 x E27 x 60W



Art.1852/BI  
ø 36 cm H 40 cm  
1 x E27 x 60W



Art.1822  
ø 50 cm H 60 cm  
1 x E27 x 60W



*La fusione d'ottone in questa collezione di lanterne, si veste di diversi stili espressivi, da brunito classico, al cromato contemporaneo, fino al bianco provenzale.*

In this collection of the lanterns brass fusion acquires different expressive styles: from classic bronzed till contemporary chromed and white colours.

Латунь в этой коллекции фонарей обретает разные экспрессивные формы, цвета и стили: от классического бронзового до современного хромированного и белого.

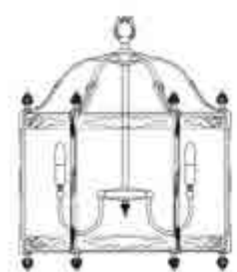

Art.1881/P  
 ø 63 cm H 76 cm  
 6 x E27 x 40W



Art.1881/M  
 ø 63 cm H 91 cm  
 6 x E27 x 40W

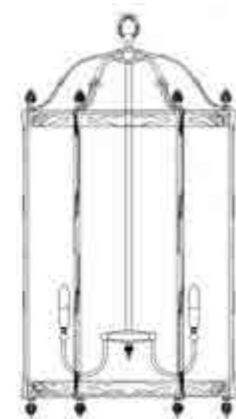

Art.1881/G  
 ø 63 cm H 120 cm  
 8 x E27 x 40W



Art.1804/G/BR  
 ø 44 cm H 85 cm  
 5 x E27 x 40W



Art. 2053/ORO24  
 L 101 cm x 62 cm H 106 cm  
 8 x E14 x 40W



Art.1804/P/KR  
Ø 21 cm H 40 cm  
1 x E27 x 60W



Art.1804/M/BI  
Ø 34 cm H 66 cm  
3 x E14 x 40W





Art.1838  
ø 47 cm H 75 cm  
5 x E14 x 40W



*La fusione d'ottone in questa collezione di lanterne, si veste di diversi stili espressivi, da brunito classico, al cromato contemporaneo, fino al bianco provenzale.*

In this collection of the lanterns brass fusion acquires different expressive styles: from classic bronzed till contemporary chromed and white colours.

Латунь в этой коллекции фонарей обретает разные экспрессивные формы, цвета и стили: от классического бронзового до современного хромированного и белого.

Art.1837/P  
ø 38 cm H 75 cm  
1 x E27 x 60W



Art.1837/G  
ø 42 cm H 114 cm  
3 x E14 x 60W







Art. 2104/OV  
ø 58 cm H 80 cm  
50 cm chain  
1 x E27 x 60W





Art.763  
L asta 80 cm  
1 x E27 x60W

*"I sottoportegghi"*



Art.734  
ø 30 cm H 22 cm  
P 67 cm  
1 x E27 x 60W

Art.738  
ø 30 cm H 45 cm  
P 60 cm  
1 x E27 x 60W

Art.733  
ø 25 cm H 14 cm  
P 50 cm  
1 x E27 x 60W



Art.763  
L asta 80 cm  
1 x E27 x60W

Art.764  
L 60 - 130 cm  
Piatto ø 30 cm  
1 x E27 x60W





Art.737  
 ø 35 cm H 32 cm  
 P 97 cm  
 1 x E27 x60W

Art.740  
 ø 35 cm H 62 cm  
 P 71 cm  
 1 x E27 x60W



Art.736  
 ø 30 cm H 32 cm  
 P 72 cm  
 1 x E27 x60W



Art.735  
 ø 25 cm H 27 cm  
 P 36 cm  
 1 x E27 x60W



Art.739/F  
 P 35 cm  
 H 19 cm ø 25 cm  
 1 x E27 x60W



Art.739  
 ø 25 cm H 19 cm  
 P 35 cm  
 1 x E27 x60W



Art.762  
 ø 45 cm  
 1 x E27 x60W



Art.761  
 Sp 30 cm H 40 cm  
 1 x E27 x 60W



Art.792  
 L 98 cm  
 H max 120 cm min 80 cm  
 1 x E27 x60W



Art.793  
 L 130 cm  
 H max 120 cm min 80 cm



422

AC 3

filo seta

AC 1

Art.739/F  
H 19 cm Sp 35 cm  
1 x E27 x60W



423

Art.884  
Sp 77 cm ø 35 cm  
1 x E27 x60W

## Faretti ad incasso

Collezione di faretti da incasso a soffitto in fusione di ottone, finito in diverse finiture e decorato a smalto in diversi colori. Fonde tradizione e ricercatezza, cura nei dettagli e innovazione.

The collection of recessed ceiling spotlights in fused brass, available in various finishings and decorated with enamel in various colours. A perfect mix of tradition and refinement, attention to detail and innovation.

Коллекция встраиваемых в потолок светильников spot light из латуни в различных покрытиях и эмалях. Слияние традиции и изысканности, внимания к деталям и инновации.



Art.1816/LU/VERDE  
 ø est 100 mm  
 ø int 53 mm  
 ø foro per incasso 65 mm  
 completo di molle - with screws

Available on green, red, blue enamel  
 Disponibile in lacca verde, blue e rossa.



Art.1882/LU  
 ø est 140 mm  
 ø int 52 mm  
 ø foro per incasso 75 mm  
 completo di molle - with screws



Art. 2048/NL  
 L 100 x 100 mm ø INT 52mm øForo per  
 incasso 65mm completo di molle-with screw

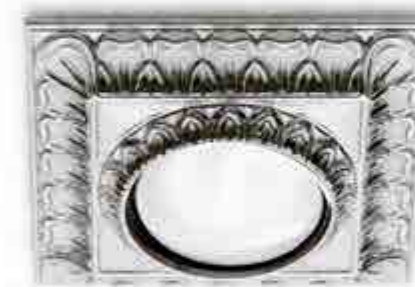

Art. 2047/NL  
 L 100 x 100 mm ø INT 52mm øForo per  
 incasso 65mm  
 completo di molle-with screw



Art.1819/OV  
 ø est 100 mm  
 ø int 52 mm  
 ø foro per incasso 65 mm  
 completo di molle - with screws



Art.1819/KR  
 ø est 100 mm  
 ø int 52 mm  
 ø foro per incasso 65 mm  
 completo di molle - with screws



Art.1819/BI  
 ø est 100 mm  
 ø int 52 mm  
 ø foro per incasso 65 mm  
 completo di molle - with screws



Art.1815/KR  
 ø est 100 mm  
 ø int 52 mm  
 ø foro per incasso 65 mm  
 completo di molle - with screws



Art.1817/LU/BLU  
 ø est 100 mm  
 ø int 52 mm  
 ø foro per incasso 65 mm  
 completo di molle - with screws



Art.1817/LU/ROSSO  
 ø est 100 mm  
 ø int 52 mm  
 ø foro per incasso 65 mm  
 completo di molle - with screws

Available on green, red, blue enamel  
 Disponibile in lacca verde, blue e rossa.

Available on green, red, blue enamel  
 Disponibile in lacca verde, blue e rossa.





Art.1856/KR  
L x L - 410 mm  
ø int 52 mm  
ø foro per incasso 85 mm  
H max 25 mm  
completo di molle  
with screws



Art.1857/BR orientabile  
ø est 120 mm ø int 52 mm  
ø foro per incasso 85 mm  
H. max 35 mm  
completo di molle - with screws



Art.1883/KR  
ø est 125 mm  
ø int 52 mm H 180 mm  
ø foro per incasso 65 mm  
completo di molle - with screws





Art.1884/KR  
Ø est 260 mm  
H 40 cm  
5 x G9



Art.1858/FO  
Ø est 125 mm Ø int 53 mm  
Ø foro per incasso 65 mm H 140 mm  
completo di molle - with screws



Art.1886/KR  
Ø est 125 mm Ø int 53 mm  
H 140 mm Ø foro per incasso 65 mm  
completo di molle - with screws

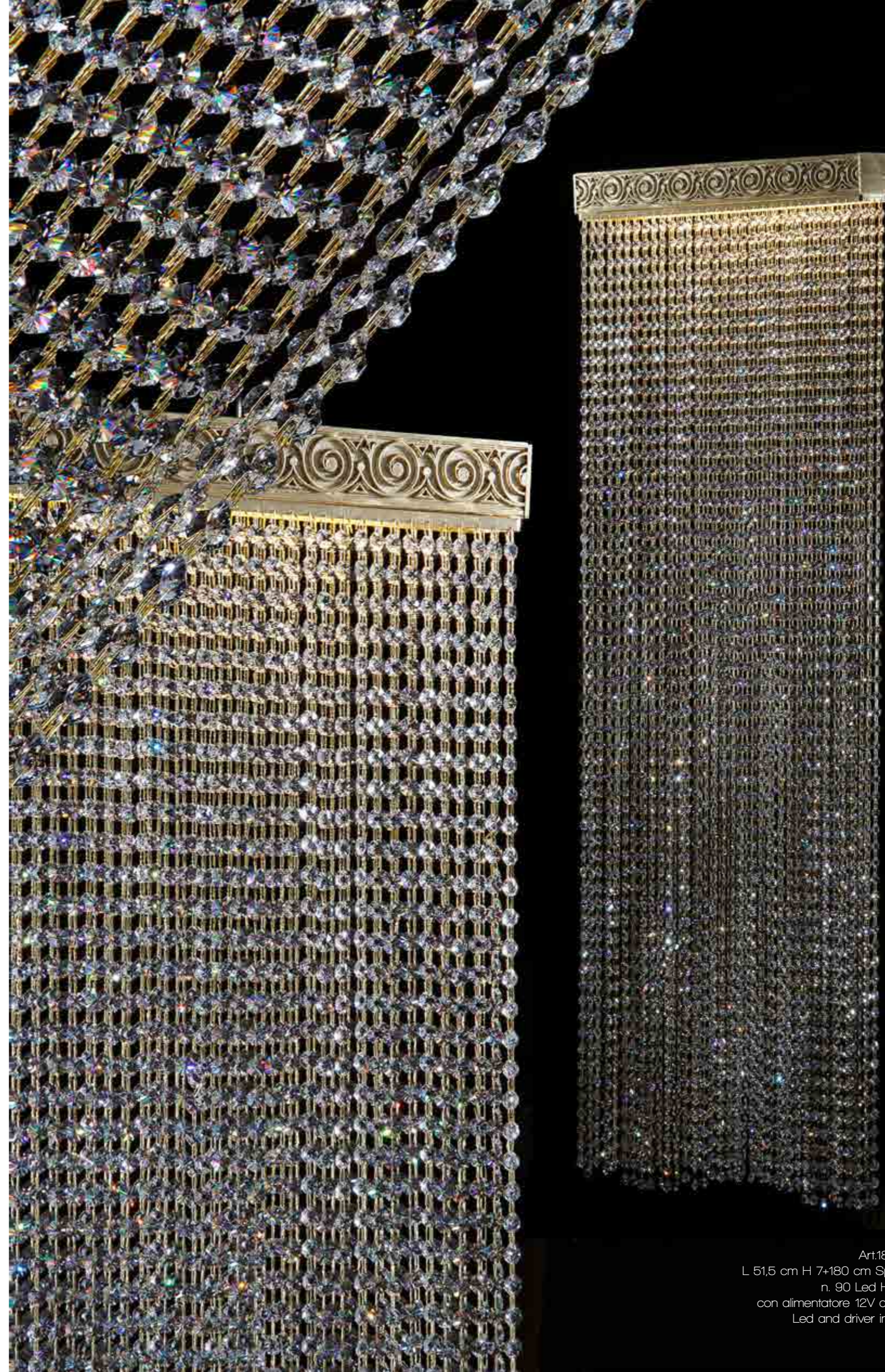

Art.1885/FO  
L 51,5 cm H 7+180 cm Sp 7 cm  
n. 90 Led HL10W  
con alimentatore 12V dc 20W  
Led and driver included





Art. 2046/LU  
ø 100 mm ø INT 52mm  
ø Foro per incasso 65mm  
completo di molle-with screw



Art. 2074/LU  
ø 16 cm H 8 cm  
1 x G9x Led 10W



Art. 2069/LU  
ø 42 cm H 12cm  
4 x G 9 x Led 10W



Art. 2075/LU  
ø 16 cm H 15 cm  
1 x G9x Led 10W



Art. 2076/LU  
ø 16 cm H 15 cm  
1 x G9x Led 10W







Art.799  
ø 42 cm  
2 x E27 x 60W



Art.798  
ø 32 cm  
2 x E27 x 60W



Art.731  
ø 32 cm  
2 x E27 x 60W



Art.732  
ø 42 cm  
2 x E27 x 60W



Art.1773/P/LU  
ø 24 cm H 17 cm  
2 x E14 x 40W

Art.1773/G/LU  
ø 38 cm H 24 cm  
3 x E14 x 60W



Art.1494/A  
ø 50 cm H 20 cm  
3 x E14 x 40W



435



Il Paralume Marina

Art.1771/P  
ø 41 cm H 20 cm  
2 x E14 x 40W

Art.1771/G  
ø 50 cm H 20 cm  
3 x E14 x 40W

Art.1772/G  
ø 50 cm H 20 cm  
3 x E14 x 40W

Art.1494/B  
ø 50 cm H 20 cm  
3 x E14 x 40W

434

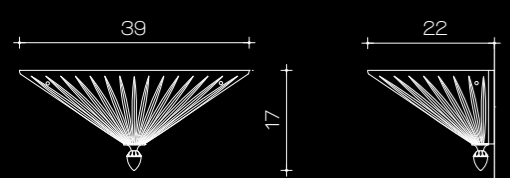

Art.1621/B Applique  
ø 39 cm H 17 cm  
1 x G9 x 40W

Art. 2038/A2/KR  
L 43 cm H 22 cm Sp 22 cm  
2 x E14 x 40W



Art. 2038/CH8/KR  
ø 95 cm H 75 cm  
8 x E14 x 40W  
+ 3 x E14 x 5W  
LED ONLY

437

Il Paralume Marina

Art.1855/OV/AM  
L 32 cm H 20 cm  
Sp max 26 cm  
2 x E14 x 40W



Picture wall lamp  
ø 31 cm Sp 25 cm ø Base 10 cm  
5 Led Luce bianco caldo 3150°K  
86 Lm/W Consumo 1 W per led



Art.1922/NL



Art.1923/NL



Art.1922/BR



Art.1922/LU

Art. 2044/LU  
L 36 cm H 17 cm Sp 20  
5 Led Luce bianco caldo 3150°K  
86 Lm/W Consumo 1 W per led



Art.1855/KR/TR  
L 32 cm H 20 cm  
Sp max 26 cm  
2 x E14 x 40W



Art.908/P  
ø 19 cm profondità 29 cm  
1 x E14 x 25W



Art.908/G  
ø 31 cm profondità 29 cm  
2 x E14 x 25W



Art. 2073/AV  
L 101 cm x 62 cm H 106 cm  
4 x G9x Led 10W



Art. 2043/A2/AV  
L 57 cm x H 11 cm Sp 24 cm  
2 x E14 x 25W



Art. 2043/A1/AV  
L 25 cm H 11 cm Sp 24 cm  
1 X E14 X 25W

Art.490  
 L 35 cm H 12 cm  
 Sp 21 cm Pø 33 cm  
 base ovale 10x6 cm  
 2 x E14 x 25W



Faretto a parete in ottone cromato e diffusore  
 in vetro di Murano trasparente soffiato a coste  
 orizzontali.

Wall lamp made on chrome brass and  
 trasparent Murano glass blown on  
 horizontal stripe.



Lamp On

Art.490/RP  
 L 42 cm P 20 cm  
 2 x E14 x 25W



Art.490/RM  
 L 32 cm P 20 cm  
 2 x E14 x 25W



Art.490/RG  
 L 22 cm P 20 cm  
 1 x E14 x 25W



Art.1409  
 L 50 cm  
 Sp max 24 cm  
 2 x E14 x 25W



Lamp Off

Art.1409/A  
 H 50 cm  
 Sp 9 cm  
 2 x E14 x 25W



5 Led Luce bianco caldo  
3150°K 86 Lm/W  
Consumo 1 W per led



Art.1492/A  
L 31 cm H 36 cm  
Sp 32 cm - led



Art.1454  
L 31 cm H 12 cm  
Sp 24 cm - led



Art.1453  
L 31 cm H 16 cm  
Sp 24 cm - led

444



Art.1492  
L 31 cm - led  
H 35 cm



Art.1463  
L 60 cm  
H 180 cm  
4 x G9x Led 10W

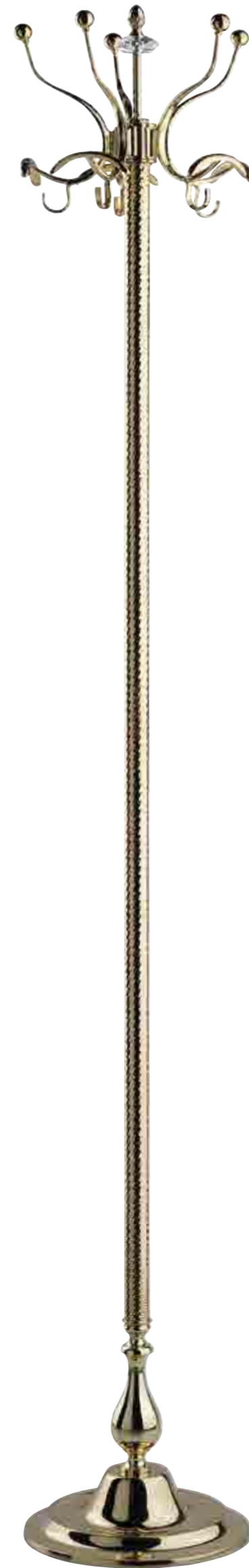

Art.1466  
H 190 cm



Art.1465  
ø 22 cm  
H 180 cm  
1 alogena 300W

445



Il Paralume Marina

N. 19

N. 20

N. 21

N. 22

N. 23

N. 24

N. 25

N. 26

N. 27

N. 28

N. 29

N. 30



446

447



N. 31

N. 32

N. 33  
L 20 cm  
ø 5 cm

N. 34  
L 47 cm  
ø 6 cm

N. 35  
L 19 cm  
ø 4 cm

N. 36  
L 38 cm  
ø 5 cm

N. 37  
L 41 cm  
ø 9 cm

N. 38  
L 70 cm  
ø 6,5 cm

N. 39  
L 40 cm  
ø 3 cm

N. 40  
L 40 cm  
ø 6 cm  
Rosa

N. 41  
L 53 cm  
ø 6,5 cm

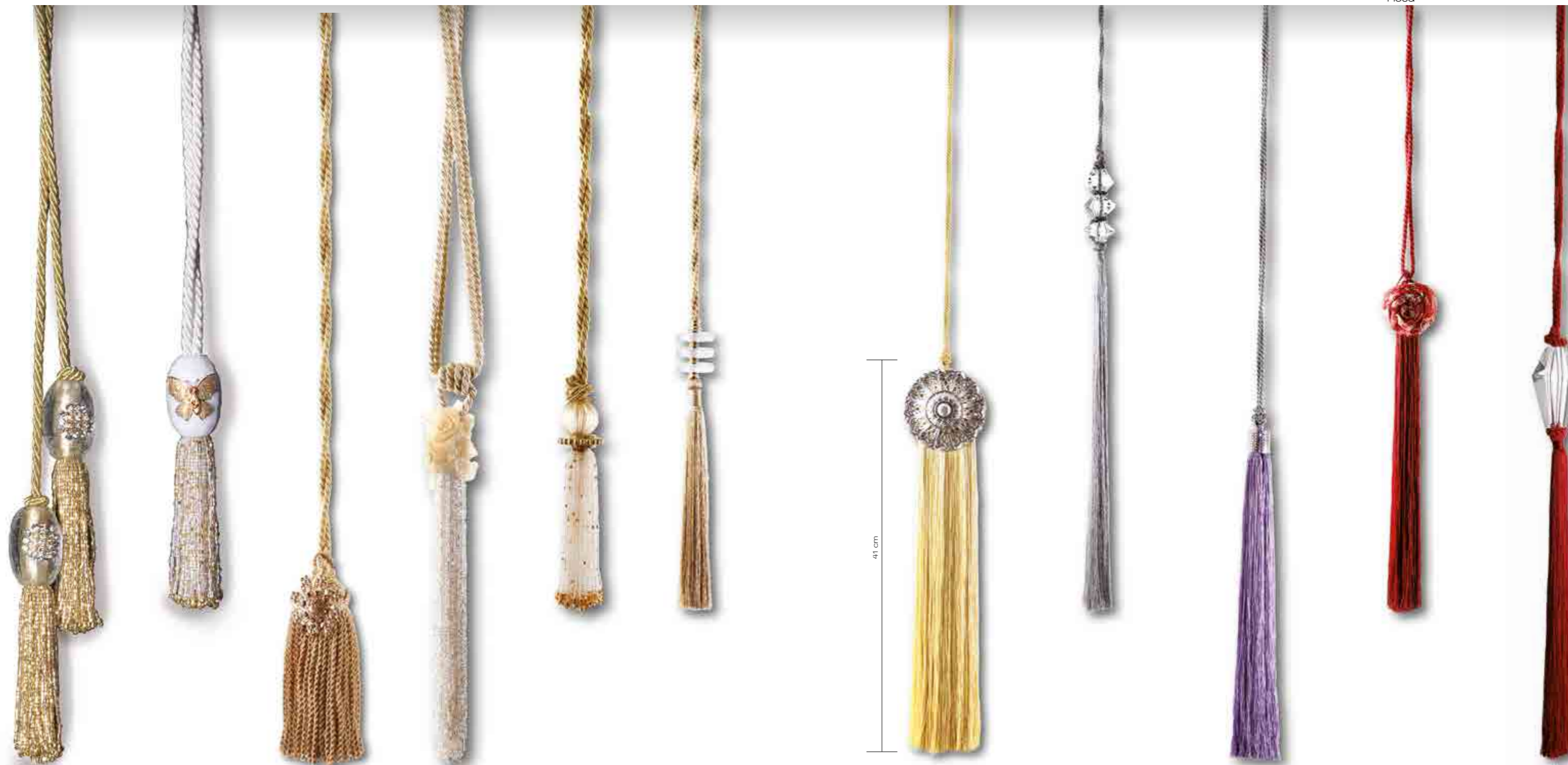

N10

N16

N17/1

N15

N12

N13

N14

N16

N17/2

N18



450

451



Strass oro

Strass bianco/oro

Grossa oro

Fascetta oro

Strass blu/oro

Strass marrone/oro

Pon-Pon

Oro semplice

Argento

Verde



Bordo 1



Bordo 2



Bordo 3



Bordo 4



Bordo 5



Bordo 6



Bordo 7



Bordo 8



Bordo 9



Bordo 10



Bordo 11



Bordo 12



Bordo 13



Bordo 14



Bordo 15



Bordo 16



Bordo 17



Bordo 18



Bordo 19



Bordo 20



Bordo 21



Bordo 22



Bordo 23



Bordo 24



Bordo 25



Bordo 26



Bordo 27



Bordo 28



Bordo 29



Bordo 30



Bordo 31



Bordo 32



Bordo 33



Bordo 34



Bordo 35 H 6 cm



Bordo 36 H 4 cm



Bordo 37 H 3 cm



Bordo 38 H 1 cm



Bordo 39 H 2,5 cm



Bordo 40 H 0,8 cm



Bordo 41 H 1,5 cm



Bordo 42 H 0,8 cm



Bordo 43 H 0,8 cm



Bordo 44 H 1,1 cm



Bordo 45 H 0,3 cm



Bordo 46 H 0,5 cm



Bordo 50 H 0,3 cm



Bordo 51 H 0,3 cm



Bordo 52 H 0,8 cm



Bordo 53 H 2,5 cm



Bordo 56 H 4 cm



Bordo 57 H 0,8 cm



Bordo 58 H 0,6 cm



Bordo 59 H 6 cm



Bordo 60 H 5 cm



Bordo 61 H 5 cm



Bordo 62 H 4 cm



Bordo 63 H 5 cm



Bordo 64 H 3,5 cm



Bordo 65 H 4 cm



Bordo 66 H 5 cm



Bordo 67 H 13 cm



Bordo 68 H 6 cm



Bordo 70 H 4 cm



Bordo 73 H 10 cm



Bordo 74 H 13 cm



Bordo 76 H 2 cm



Bordo 77 H 2 cm



Bordo 78 H 2 cm



Bordo 79 H 2 cm



Bordo 80 H 1 cm



Bordo 81 H 1,2 cm



Bordo 82 H 3 cm



Bordo 83 H 2,5 cm



Bordo 84 H 0,7 cm



Bordo 85 H 0,6 cm



Bordo 86 H 1,3 cm



Bordo 87 H 4,5 cm

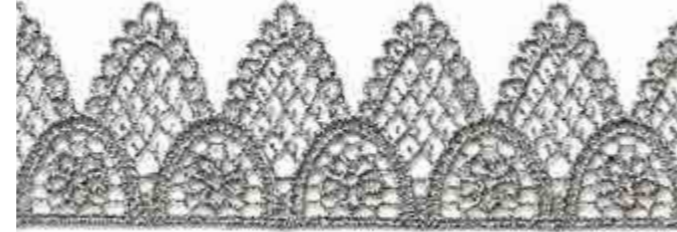

Bordo 88 H 6 cm



Bordo 89 H 3 cm



Bordo 90 H 0,9 cm



Bordo 93 H 3,4 cm



Bordo 94 H 5 cm



Bordo 95 H 5 cm



Bordo 96 H 5 cm



Bordo 97 H 5 cm



Bordo 98 H 4 cm



Bordo 100 H 0,8 cm



Bordo 101 H 0,5 cm



Bordo 102 H 0,5 cm



Bordo 104 H 3,8 cm



Bordo 105 H 4,5 cm



Bordo 106 H 2 cm



# Il Paralume Marina

*Made in Italy*  
since 1987

Marina Luce Vol. 1  
*Contemporary*





1 2 3 4 5 6 7 8



70 71 72 73 74 75 76 77 78



10 11 12 13 14 15 16 17 18



80 81 82 83 84 85 86 87 88



20 21 22 23 24 25 26 27 28



90 91 92 93 94 95 96 97 98



30 31 32 33 34 35 36 37 38



100 101 102 103 104 105 106 107 108



40 41 42 43 44 45 46 47 48



110 111 112 113 114 115 116 117 118



50 51 52 53 54 55 56 57 58



120 121 122 123 124 125 126 127 128



60 61 62 63 64 65 66 67 68



130 131 132 133 134 135 136 137 138

462

463





140

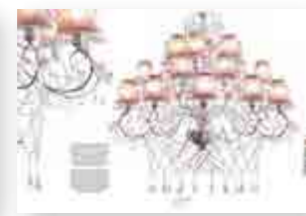

142



144



146



148



210



212



214



216



218



150



152



154



156



158



220



222



224



226



228

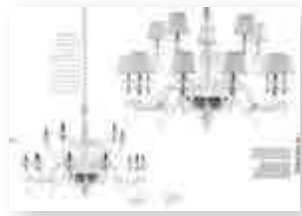

160



162



164



166



168



230



232



234



236



238



170



172



174



176



178



240



242



244



246



248



180



182



184



186



188



250



252



254



256



258



190



192



194



196



198



260



262



Table Lamps



264



266



200



202



204



206



208



268



270



272



274



276



278



280



282



284



286



348



350



352



354



356



288



290



292



294



296



358



360



362

Appliques



364



298



300



302



304



306



366



368



370



372



374



308



310'



312



314



316



376



378



380



382



384



318



320



322



324



326



386



388



390



392



394

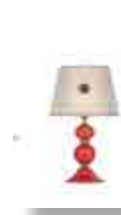

328



330



332



334



336



396



398



400



402



404



338



340



342



344



346



406



408



410



412



414



416 418 420 422 424



426 428 430 432 434



436 438 440 442 444

Spotlights



*Handmade, it's A Surplus  
The added value of marina luce will  
always be the quality of our products.  
All the chandeliers come out the  
factory as unique pieces handmade  
one by one by our incredibly talented  
seamstresses. They are led by the one  
and only Marina, the founder of  
the company and master of beauty,  
that hands down all the secrets to the  
new generation.*



Art. 1954/G  
Pø 29 cm H 92 cm  
1 x E27 x 60W  
  
Art. 1954/P  
Pø 23 cm H 67 cm  
1 x E27 x 40W

Art.1948/LU  
P oval 46x25 cm H 98 cm  
1 x E27 x 60W  
Nappa N.10 Oro





SWAROVSKI® è un marchio registrato



Atelier del Paralume  
Atelier lampshades  
Ателье абажуров

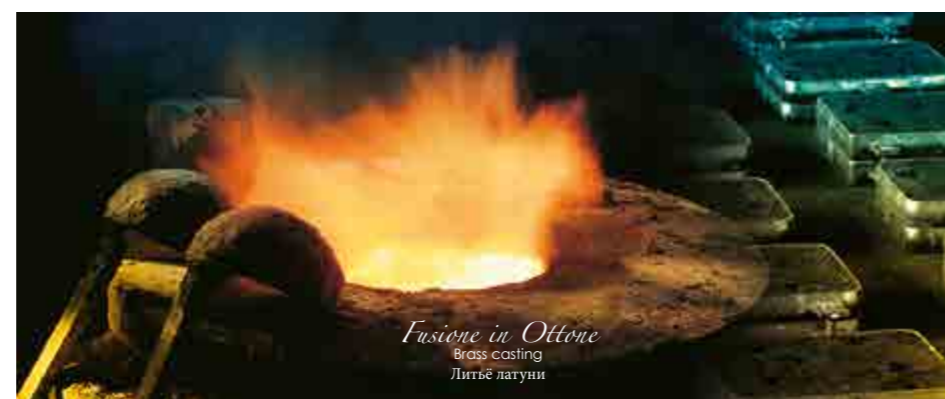

Fusione in Ottone  
Brass casting  
Литье латуни



Vetro di Murano  
Murano glass  
Муранское стекло



Cristallo Italiano  
Italian Crystal  
Итальянский хрусталь

• La Passione, la dedizione e la cura attentissima del dettaglio, animano l'atelier della Signora Marina. Moderne tecnologie affiancano lavorazioni manuali tradizionali x ottenere un prodotto totalmente esclusivo e di eccellenza, 100% Made in Italy . La continua ricerca e innovazione di tessuti e passamanerie rende Il Paralume Marina Leader nel creare oggetti su misura.

• *Passion, dedication and careful attention to detail bring to life the workshop of Mrs. Marina. Modern technologies alongside traditional manual processes obtain a product totally unique and of high quality, 100% Made in Italy. The continuous research and innovation of fabrics and trimmings makes Il Paralume Marina, the Leader in creating custom-made products.*

• В ателье госпожи Марины царят Вдохновение, Страсть, Самоотдача и высочайшее Внимание к деталям. Современные технологии идут рука об руку с традиционными техниками рукоделия, воплощаясь в эксклюзивном продукте, 100% сделанном в Италии. Постоянные исследования и применения последних инноваций в тканях и окантовках делают Il Paralume Marina лидером среди производителей персонализированных изделий.

• La fusione in terra dell'ottone è un'arte antica, che ancora oggi sa emozionare. La pressofusione crea oggetti di eccellenza e di altissima qualità sinonimi di lusso ed eleganza esclusivamente made in Italy. Fondiamo metallo trasformando l'idea di architetti e designer in oggetti esclusivi, dal prototipo allo stampo, al prodotto finito.

• *Brass sand casting is an ancient art, which still continues to excite. Casting creates objects of excellence and of the highest quality, demonstrating luxury and elegance exclusively made in Italy. We base metal transformation on the ideas of exclusive product architects and designers, from the prototype, to the mould, to the finished product.*

• Литье латуни «в землю» - это античное искусство, которое и сегодня способно вызывать эмоции. Литье создает предметы высокого качества с особым благородным шармом, присущим роскошным интерьерам, сделанным исключительно в Италии. Мы плавим металл, трансформируя идею архитектора и дизайнера в эксклюзивные предметы: от прототипа – к штампу – до законченного продукта

• Maestri artigiani che tramandano l'arte antica muranese garantiscono un prodotto di classe di alta gamma e qualità indiscutibili. La produzione interamente artigianale e l'uso di tecniche raffinate rendono ogni oggetto un pezzo unico. L'esperienza dei maestri per noi è un punto di partenza per creare oggetti attuali di arredamento e di emozione. La forza del Paralume Marina è la qualità eccellente e la flessibilità nell'assecondare le richieste di un mercato internazionale sempre in evoluzione.

• *Master craftsmen who hand down the ancient art of Murano guarantee a high-class product of unquestionable quality. Total handmade production and the use of sophisticated techniques make each product unique. The experience of the master craftsmen is a starting point for us to create real pieces of furniture of emotion. The strength of Il Paralume Marina is the excellent quality and flexibility to adapt to the demands of an ever changing market.*

• Мастера-ремесленники передают античное искусство муранского стекла из поколения в поколение, что гарантирует их изделиям высочайший уровень качества. Изготовление вручную и использование искусных техник делают каждое их творение уникальным и неповторимым. Опыт Мастеров является для нас отправной точкой для создания актуальных предметов интерьера с ярким эмоциональным оттенком. Сильной стороной Il Paralume Marina является безупречное качество и гибкость в подходе к требованиям динамичного и такого разнообразного международного рынка.

• Il cristallo è orgogliosamente solo italiano. Si ottiene fondendo in appositi forni a temperatura elevata, superiore a 1400°, utilizzando materie prime di qualità superiore si ottiene un prodotto con oltre il 24% di PbO, che conferisce una luminosità e trasparenza indiscutibili. La lavorazione del cristallo è eseguita artigianalmente; viene soffiato a bocca e le incisioni sono eseguite interamente a mano per cui ogni oggetto diviene "Oggetto d'Arte".

• *Paralume Marina proudly uses only Italian crystal. It is made by melting in special high temperature furnaces, exceeding 1400°, using optimum quality raw materials a product is obtained with over 24% of PbO, which gives an undeniable brightness and clarity. The processing of crystal is carried out by hand; it is blown and the incisions are made entirely by hand so that every object becomes an "Objet d'art".*

• Исключительно лучший итальянский хрусталь является нашей гордостью и отличительной чертой. Его получают посредством плавки в специальных печах при высокой температуре, превышающей 1400°, используя материалы лучшего качества. Это позволяет получить продукт с процентом свинца в составе в 24% и выше, что придает изделиям безупречную прозрачность и яркость. Обработка хрусталя проходит вручную: его выдувают, а затем гравировать полностью вручную, что гарантирует каждому изделию титул Произведения Искусства.

# Il Paralume Marina



*Luxury Light Made in Italy*

## Il Paralume Marina

Classic Lighting

Design: Arch. Federica Vicentini  
Proget Director: Thomas Simoncello  
Printing: Girardi Print Factory

Tutte le misure sono indicate in cm  
H = altezza, L = larghezza,  
ø = diametro, Pø = diametro del paralume,  
Sp = sporgenza.

Tutti i diritti riservati.  
Sono vietate la pubblicazione la trasmissione la fotocopiatura e qualsiasi altra forma di duplicazione o riproduzione, parziali e totali dei testi e della grafica qui contenuti, senza il preventivo consenso scritto della ditta il Paralume Marina. Il produttore si riserva il diritto di introdurre modifiche tecnologiche. Il produttore declina qualsiasi responsabilità per eventuali errori di stampa.

Il Paralume Marina s.r.l.  
Vicolo Col Beretta, 6  
36022 San Zeno di Cassola (VI) ITALY

Tel +39 0424 33 042  
FAX +39 0424 511 817

[www.ilparalumemarina.com](http://www.ilparalumemarina.com)  
[info@ilparalumemarina.it](mailto:info@ilparalumemarina.it)  
Skype: ilparalumemarina

*Made in Italy*  
Since 1987



Ogni progetto è una sfida che affrontiamo con serietà e passione, dedizione al cliente e cura nei dettagli maniacale. Il Paralume Marina con la sua esperienza e con il suo team interno di designer e ingegneri, garantisce un servizio esclusivo ai professionisti che desiderano utilizzare soluzioni di illuminazione decorativa nei loro progetti, proponendo alternative stilistiche, tecniche ed economiche adeguate alla richieste della committenza.

*Each project is a challenge that we approach with seriousness and passion, dedication to the customer and meticulous attention to detail. Il Paraluma Marina with its experience and in-house team of designers and engineers, guarantees an exclusive service for users who wish to use decorative lighting solutions in their projects, offering stylistic, technical and inexpensive options adapted to the demand of the client.*

Каждый проект – это вызов, который мы принимаем с максимальной серьезностью и страстью, преданностью клиенту и маниакальным вниманием к деталям. Il Paralume Marina со своим опытом и собственной сплоченной командой дизайнеров и инженеров, гарантирует эксклюзивный сервис для профессионалов, которые желают включить в собственные проекты смелые решения по декоративному освещению, предлагая стилистические, технические и экономические альтернативы, оптимально адаптированные под запрос Заказчика.



# Il Paralume Marina

*Made in Italy*  
since 1987



[www.ilparalumemarina.it](http://www.ilparalumemarina.it)