

VEBLÉN



VEBLÉN



Luxury Edition by Fiam Italia



Villa Miralfiore Anni '50 - Foto archivio Miralfiore
Villa Miralfiore in the 1950s - Shots from Miralfiore archive

La storia di VEBLÉN nasce lontana nel tempo, una cultura di design partita dall'Italia, le cui radici, legate all'eleganza, al gusto per il bello, all'artigianalità, hanno influenzato il gusto dell'arredamento, stabilendo regole nuove ed entrando a far parte dell'immaginario del jet-set internazionale.

Con il cristallo, materiale tra i più antichi nella storia dell'uomo, da sempre sinonimo di agiatezza e stile per chi lo possiede, a partire dalle aristocratiche famiglie egizie ritratte nei geroglifici con i loro monili in vetro, FIAM Italia conquista le abitazioni più famose del mondo, diventando terreno fertile per le idee dei designer più prestigiosi e brand riconosciuto da un pubblico particolarmente attento e raffinato.

VEBLÉN parte dalla storia scritta dalla famiglia Livi sul vetro e cristallo, dal know how raggiunto sull'esclusività delle forme e si fa, ora, interprete del desiderio di chi voglia arricchire la propria dimora con arredi preziosi che comunichino eleganza con maggiore enfasi.

VEBLÉN trova sede nella prestigiosa cornice di Villa Miralfiore, dimora quattrocentesca, riportata all'antico splendore dalla famiglia Livi, dove tra stucchi, affreschi e decorazioni prende vita il fascino di VEBLÉN.

Proprio da questo luogo, ricco di cultura, arte e del buon vivere, nascono il simbolo ed il nome della VEBLÉN: l'ermellino, un animale emblema di aristocratica purezza e regalità, è stato scoperto durante il restauro della Villa; il nome è stato ispirato dalle misteriose leggende che la circondano.

Chi ne sceglie i prodotti, si appropria di frammenti di tradizioni e saperi senza tempo.

The history of VEBLÉN has origins far away in time, a design culture that was born in Italy, whose roots, connected to elegance, taste for beauty and craftsmanship, have influenced the taste for furniture, establishing new rules and becoming part of the idealistic international jet-set.

With crystal, one of the most ancient materials in human history which has always been synonym of wealth and style for the owner, starting from the aristocratic Egyptian families portrayed in hieroglyphs with their glass trinkets, FIAM Italia has conquered the most famous homes of the world, becoming fertile ground for the ideas of the most prestigious designers and brands recognized by a particularly attentive and refined audience.

VEBLÉN has its starting point in the history written by the Livi family on glass and crystal, in the know-how gained on the exclusivity of shapes, and is now an interpreter of the desire of those who want to enrich their lives with precious furnishings that convey elegance with greater emphasis.

VEBLÉN is established in the prestigious setting of Villa Miralfiore, a fifteenth-century residence, restored to its former glory by the Livi family, where - among stuccos, frescos and decorations - the charm of Veblén comes to life.

It is from this place, full of culture, art and good living, that the symbol and name of Veblén originate: the ermine, an animal that symbolizes aristocratic purity and regality, was discovered during the restoration of the Villa; the name was inspired by the mysterious legends that surround it.

Those who choose its products, receive fragments of timeless traditions and knowledge.





Queen Elizabeth
poltroncina - armchair

Dimensioni (cm) L. P. H.
Dimensions (cm) L. W. H.

86 x 69 x 106
33 7/8" x 27 3/16" x 41 3/4"





Versailles

boiserie

Dimensioni (cm) L. P.H.
Dimensions (cm) L. W. H.
80 x 3 x 240
31 1/2" x 1 13/16" x 94 1/2"









New Baroque
specchio - mirror

Dimensioni (cm) L. P. H.
Dimensions (cm) L. W. H.

110 x 5 x 220
43 5/16" x 2" x 86 5/8"







New Baroque
specchio - mirror

Dimensioni (cm) L. P. H.
Dimensions (cm) L. W. H.

sagomato / shaped
128 x 5 x 180
50 3/8" x 2" x 70 7/8"

rettangolare / rectangular
110 x 5 x 220
43 5/16" x 2" x 86 5/8"

tondo / round
Ø 150 x 5
Ø 59" x 2"

New Baroque
specchio - mirror

Dimensioni (cm) L. P. H.
Dimensions (cm) L. W. H.

128 x 5 x 180
50 3/8" x 2" x 70 7/8"





New Baroque
specchio - mirror





New Baroque
specchio - mirror

Dimensioni (cm) L. P.H.
Dimensions (cm) L. W. H.

180 x 5 x 128
70 7/8" x 2" x 50 3/8"



Trinity
specchio - mirror

Dimensioni (cm) L. P. H.
Dimensions (cm) L. W. H.

ellittico / elliptical	sagomato / shaped
40 x 1,5 x 60	40 x 1,5 x 60
15 3/4" x 9/16" x 23 5/8"	15 3/4" x 9/16" x 23 5/8"
	53 x 1,5 x 65
	20 7/8" x 9/16" x 25 9/16"
	55 x 1,5 x 80
	21 5/8" x 9/16" x 31 1/2"
	80 x 1,5 x 140
	31 1/2" x 9/16" x 55 1/8"





Trinity
specchio - mirror







Arabesque
console



Arabesque
consolle

Dimensioni (cm) L. P. H.
Dimensions (cm) L. W. H.

150 x 42 x 73
59" x 16 ⁹/₁₆" x 28 ³/₄"





Venice

consolle

Dimensioni (cm) L. P.H.
Dimensions (cm) L. W. H.

150 x 53 x 76
59" x 20 7/8" x 30"





Venice
console



Venice

tavolo - table

Dimensioni (cm) L. P. H.
Dimensions (cm) L. W. H.

150 x 100 x 76
59" x 39 3/8" x 30"







Venice
tavolo - table

Dimensioni (cm) L. P.H.
Dimensions (cm) L. W. H.

220 x 120 x 76
86 5/8" x 47 3/4" x 30"
300 x 120 x 76
118 1/8" x 47 3/4" x 30"









Cocò
tavolo - table

Dimensioni (cm) L. P. H.
Dimensions (cm) L. W. H.

tondo / round
Ø 158 x 74 - 76
Ø 62 ³/₁₆" x 29 ¹/₈" - 30"

rettangolare / ovale
rectangular / oval
360 x 120 x 74
141 ³/₄" x 47 ¹/₄" x 29 ¹/₈"





Arabesque
tavolo - table





Arabesque

tavolo - table

Dimensioni (cm) L. P.H.
Dimensions (cm) L. W. H.

quadrato / square
140 x 140 x 76
55 1/8" x 55 1/8" x 30"

ellittico / elliptical
250 x 130 x 76
98 7/16" x 51 3/16" x 30"

rettangolare / rectangular
250 x 120 x 76
98 7/16" x 47 1/4" x 30"

360 x 120 x 76
141 3/4" x 47 1/4" x 30"

tondo / round
Ø 158 x 76
Ø 62 3/16" x 30"



Arabesque
tavolo - table



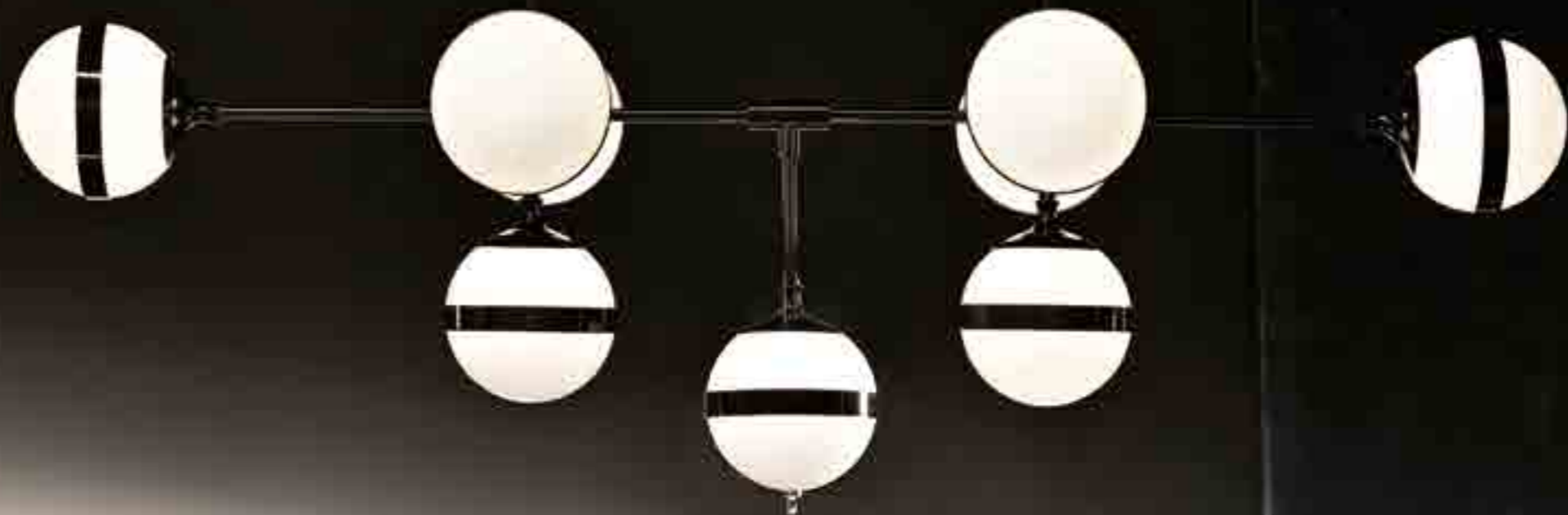

Arabesque
tavolo - table





Sophia
sedia - chair

Dimensioni (cm) L. P. H.
Dimensions (cm) L. W. H.

51 x 66 x 104
20" x 25" x 41"





Audrey
sedia - chair

Dimensioni (cm) L. P. H.
Dimensions (cm) L. W. H.
50 x 63 x 110
19 ¹¹/₁₆" x 24 ¹³/₁₆" x 43 ⁵/₁₆"



Burberry
vetrina - showcase

Dimensioni (cm) L. P. H.
Dimensions (cm) L. W. H.

Burberry	Burberry King
64 x 37 x 166	100 x 44 x 162
25 ³ / ₁₆ " x 14 ⁹ / ₁₆ " x 65 ³ / ₈ "	39 ³ / ₈ " x 17 ⁵ / ₁₆ " x 63 ³ / ₄ "





Notre Dame

vetrina - showcase

Dimensioni (cm) L. P.H.
Dimensions (cm) L. W. H.
140 x 50 x 130
55 1/8" x 19 11/16" x 51 3/16"



Ducale

tavolino - coffee table

Dimensioni (cm) L. P. H.
Dimensions (cm) L. W. H.

quadrato / square	rettangolare / rectangular
130 x 130 x 40	160 x 100 x 40
51 ³ / ₁₆ " x 51 ³ / ₁₆ " x 15 ³ / ₄ "	62" x 39 ³ / ₈ " x 15 ³ / ₄ "



Bohème
tavolino - coffee table

Dimensioni (cm) L. P. H.
Dimensions (cm) L. W. H.
160 x 100 x 35
62" x 39 3/8" x 13 3/4"



Rocks
tavolino - coffee table



Rocks
tavolino - coffee table





Rocks
tavolino - coffee table

Dimensioni (cm) L. P. H.
Dimensions (cm) L. W. H.

80 x 80 x 28
31 1/2" x 31 1/2" x 11"



Rocks
tavolino - side table

Dimensioni (cm) L. P.H.
Dimensions (cm) L. W. H.
40 x 40 x 70
15 3/4" x 15 3/4" x 27 9/16"





Icon
tavolino - coffee table

Dimensioni (cm) L. P. H.
Dimensions (cm) L. W. H.

Ø 50 x 55
Ø 19 ¹¹/₁₆" x 21 ⁵/₈"
Ø 65 x 45
Ø 25 ⁹/₁₆" x 17 ¹¹/₁₆"
Ø 90 x 35
Ø 35 ⁷/₁₆" x 13 ³/₄"

Napoleon
porta-tv - tv cabinet





Napoleon
porta-tv - tv cabinet

Dimensioni (cm) L. P. H.
Dimensions (cm) L. W. H.
189 x 43 x 189
74 7/16" x 17" x 74 7/16"

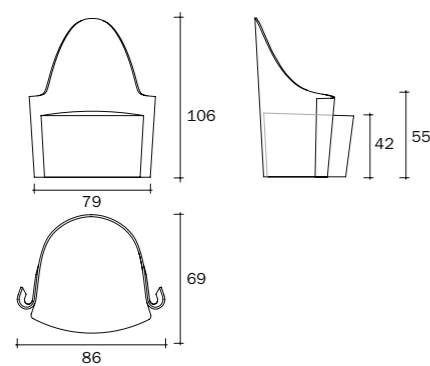

Queen Elizabeth

Poltroncina con struttura in vetro curvato da 10 mm e seduta imbottita rivestita in pelle o tessuto. Struttura disponibile in vetro fumè o bronzo.

Armchair with 10 mm curved glass structure and upholstered seat covered with leather or fabric. Structure available in smoked or bronze glass.

Dimensioni (cm) L. P.H.
Dimensions (cm) L. W. H.

86 x 69 x 106
33 7/8" x 27 3/16" x 41 3/4"

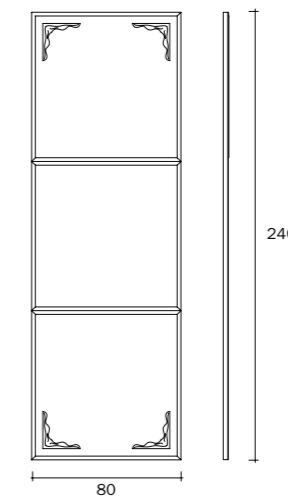

Versailles

Boiserie composta da 3 moduli quadrati a specchio in vetro fumè o bronzo da 5 mm molato, arricchiti da fregi angolari in resina. Struttura in fibra di legno ed alluminio.

Panelling consisting of 3 square mirror modules made of 5 mm bevelled smoked or bronze glass, decorated with angular resin friezes. Structure made of wood fibre and aluminium.

Dimensioni (cm) L. P.H.
Dimensions (cm) L. W. H.
80 x 3 x 240
31 1/2" x 1 13/16" x 94 1/2"

Composizione di tre
Composition of three
240 x 3 x 240
94 1/2" x 1 13/16" x 94 1/2"

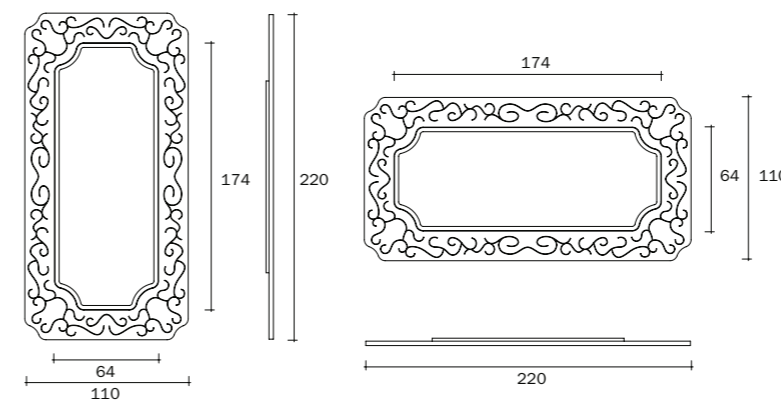
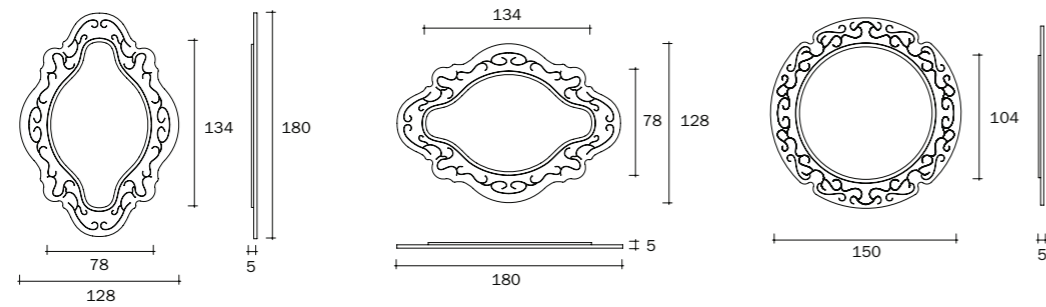

New Baroque

Specchio da parete sagomato costituito da cornice in vetro fuso a gran fuoco da 6 mm retroargentato con decoro a rilievo. Disponibile nelle finiture fumè o bronzo. Specchio piano da 5 mm disponibile nelle finiture neutro, fumè o bronzo. Telaio posteriore in metallo verniciato. Possibilità di appendimento in orizzontale o verticale.

Shaped wall mirror consisting of a 6 mm fused glass frame back-silvered with relief decorations. Available with smoked or bronze finishes. 5 mm flat mirror available with neutral, smoked or bronze finishes. Rear frame made of painted metal. It can be hung horizontally or vertically.

Dimensioni (cm) L. P.H.
Dimensions (cm) L. W. H.

sagomato / shaped
128 x 5 x 180
50 3/8" x 2" x 70 7/8"

rettangolare / rectangular
110 x 5 x 220
43 5/16" x 2" x 86 5/8"

tondo / round
Ø 150 x 5
Ø 59" x 2"

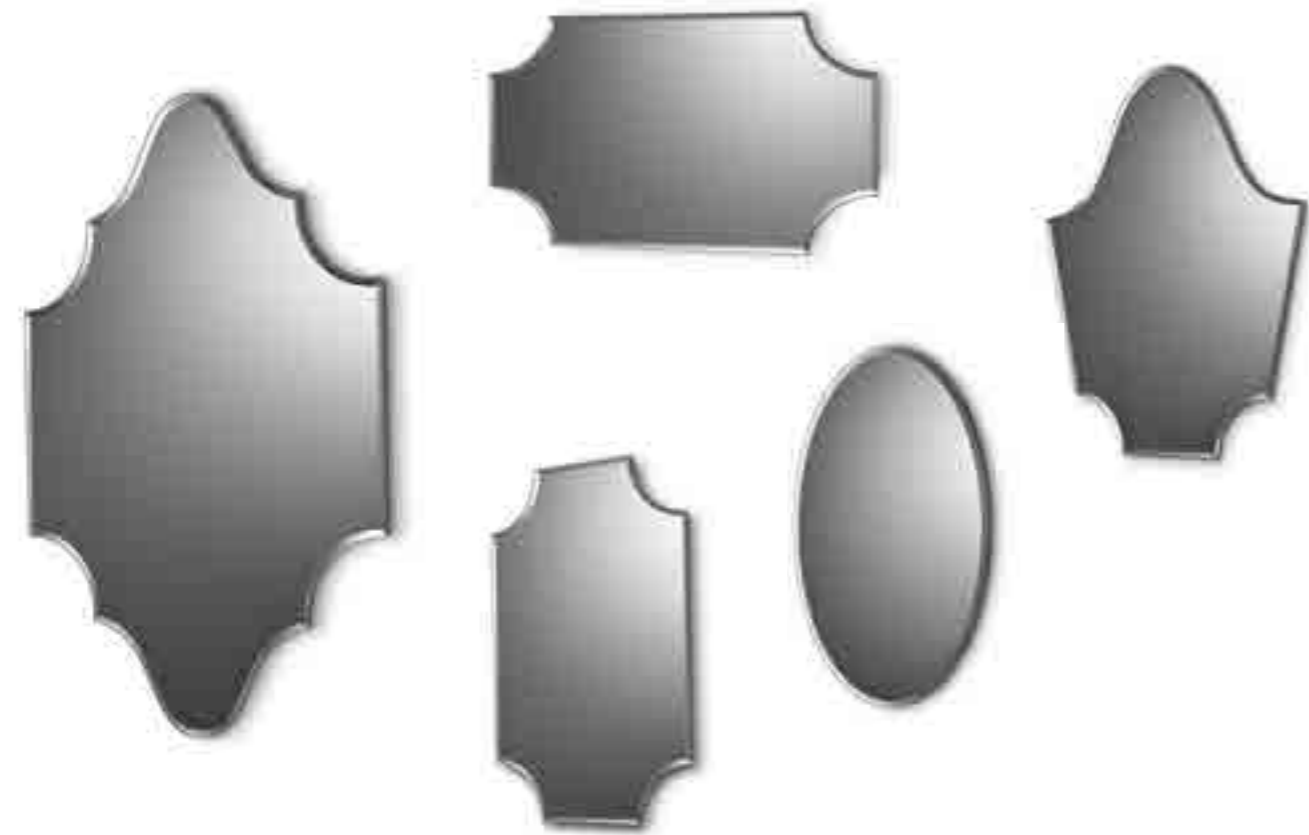

MODULO A
MODULE A

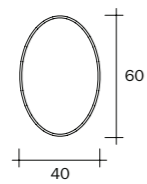

MODULO B
MODULE B

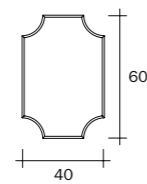

MODULO C
MODULE C

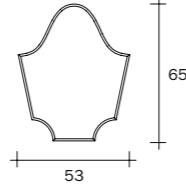

MODULO D
MODULE D

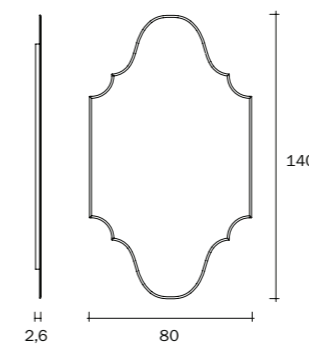
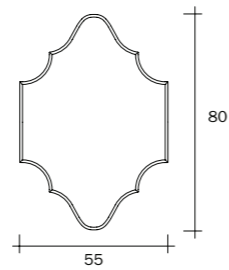

Trinity

Specchio da parete
in vetro fumè da 6 mm
sagomato e molato.
Telaio posteriore
in metallo.

Wall mirror in 6 mm
shaped and bevelled
smoked glass.
Metal rear frame.

Dimensioni (cm) L. P. H.
Dimensions (cm) L. W. H.

ellittico / elliptical
40 x 1,5 x 60
15 3/4" x 9/16" x 23 5/8"

sagomato / shaped
40 x 1,5 x 60
15 3/4" x 9/16" x 23 5/8"
53 x 1,5 x 65
20 7/8" x 9/16" x 25 9/16"
55 x 1,5 x 80
21 5/8" x 9/16" x 31 1/2"
80 x 1,5 x 140
31 1/2" x 9/16" x 55 1/8"

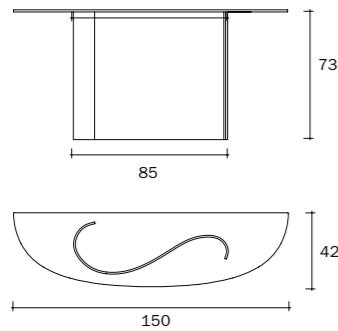

Arabesque

Consolle con piano in vetro temperato da 10 mm. Base in vetro curvato da 10 mm. Disponibile in vetro fumè o bronzo.

Console with 10 mm tempered glass top. Base made of 10 mm curved glass. Available in smoked or bronze glass.

Dimensioni (cm) L. P.H.
Dimensions (cm) L. W. H.
150 x 42 x 73
59" x 16 9/16" x 28 3/4"

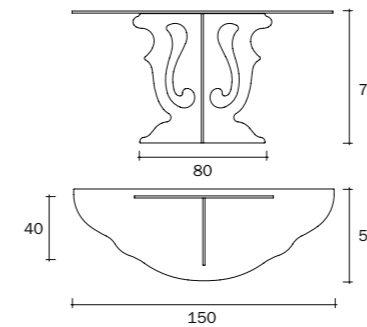

Venice

Consolle con piano in vetro fumè temperato da 12 mm. Base composta da elementi in vetro fumè temperato da 12 mm sagomati ed incollati.

Console consisting of a 12 mm tempered smoked glass top. Base consistig of 12 mm tempered shaped glass elements in smoke finish.

Dimensioni (cm) L. P.H.
Dimensions (cm) L. W. H.
150 x 53 x 76
59" x 20 7/8" x 30"

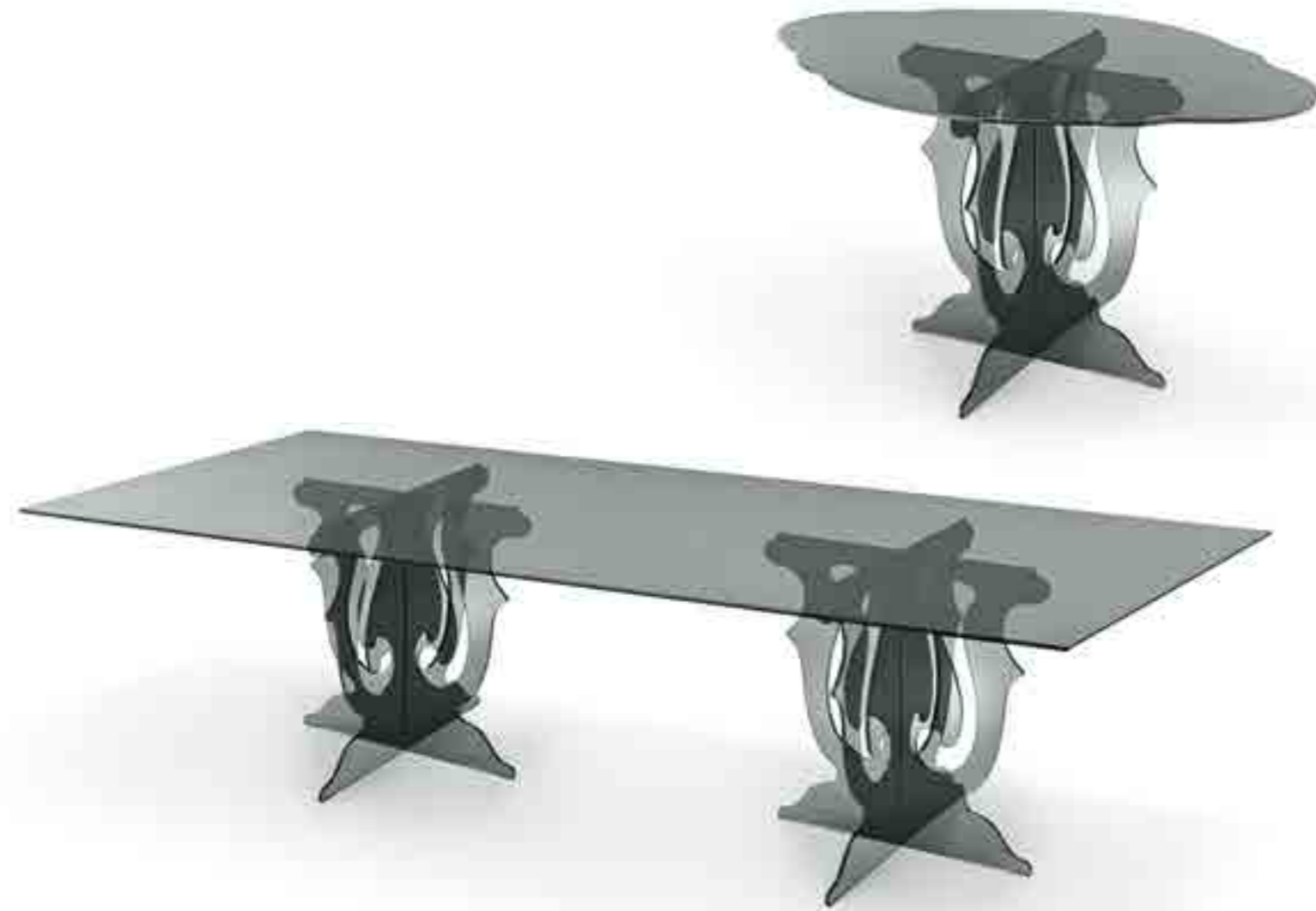

Venice

Tavolo con piano sagomato o rettangolare, bisellato in vetro fumè temperato da 12 mm. Base composta da elementi in vetro fumè temperato da 12 mm sagomato ed incollato. Base disponibile a 3 o 4 razze, in funzione delle dimensioni del piano.

Dimensioni (cm) L. P. H.
Dimensions (cm) L. W. H.

sagomato / shaped
150 x 100 x 76
59" x 39 3/8" x 30"

Table with a shaped or rectangular top made of 12 mm tempered smoked glass, bevelled. Base made of 12 mm tempered smoked glass elements, shaped and glued. Base available with 3 or 4 spokes, depending on the size of the top.

rettangolare / rectangular
220 x 120 x 76
86 5/8" x 47 1/4" x 30"
300 x 120 x 76
118 1/8" x 47 1/4" x 30"

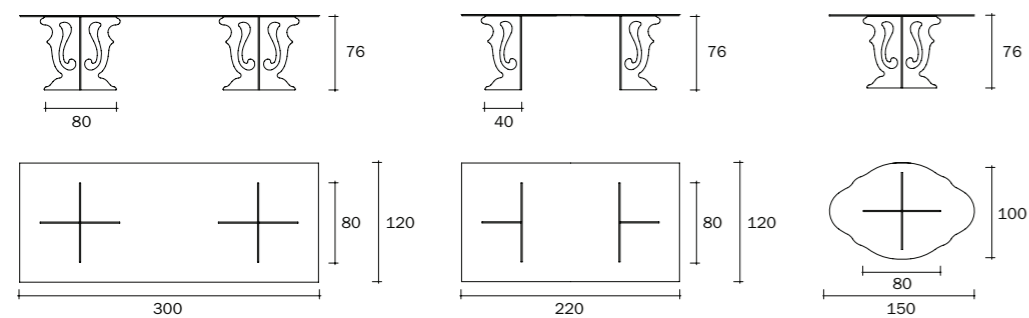

Cocò

Tavolo con piano in vetro fumè o impiallacciato frassino verniciato nero a poro aperto. Base composta da elementi in vetro fumè da 12 mm temperato, sagomati e disposti a raggiera.

Dimensioni (cm) L. P. H.
Dimensions (cm) L. W. H.

tondo / round
Ø 158 x 74 - 76
Ø 62 3/16" x 29 1/8" - 30"

Table with a smoked glass or an open pore, black painted veneered ash top. Base made of 12 mm tempered smoked glass, shaped and arranged in spokes.

rettangolare / rectangular
ovale / oval
360 x 120 x 74
141 3/4" x 47 1/4" x 29 1/8"

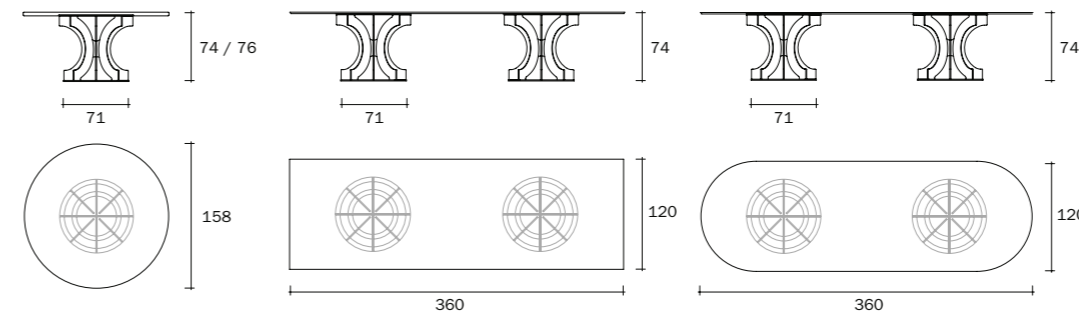

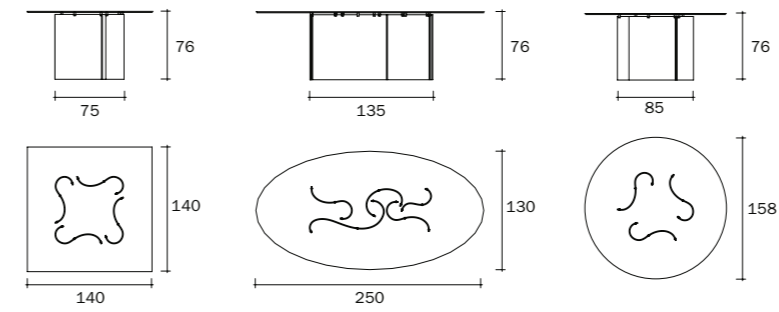
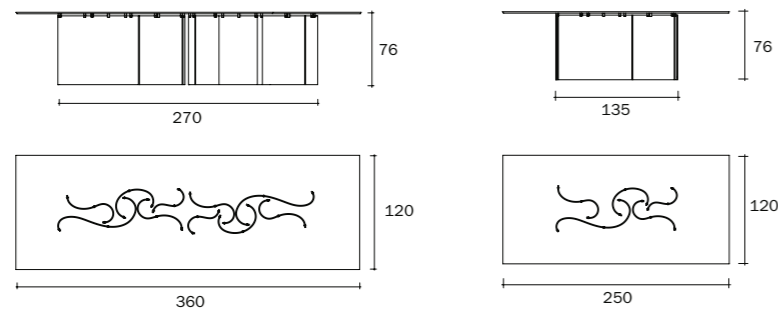
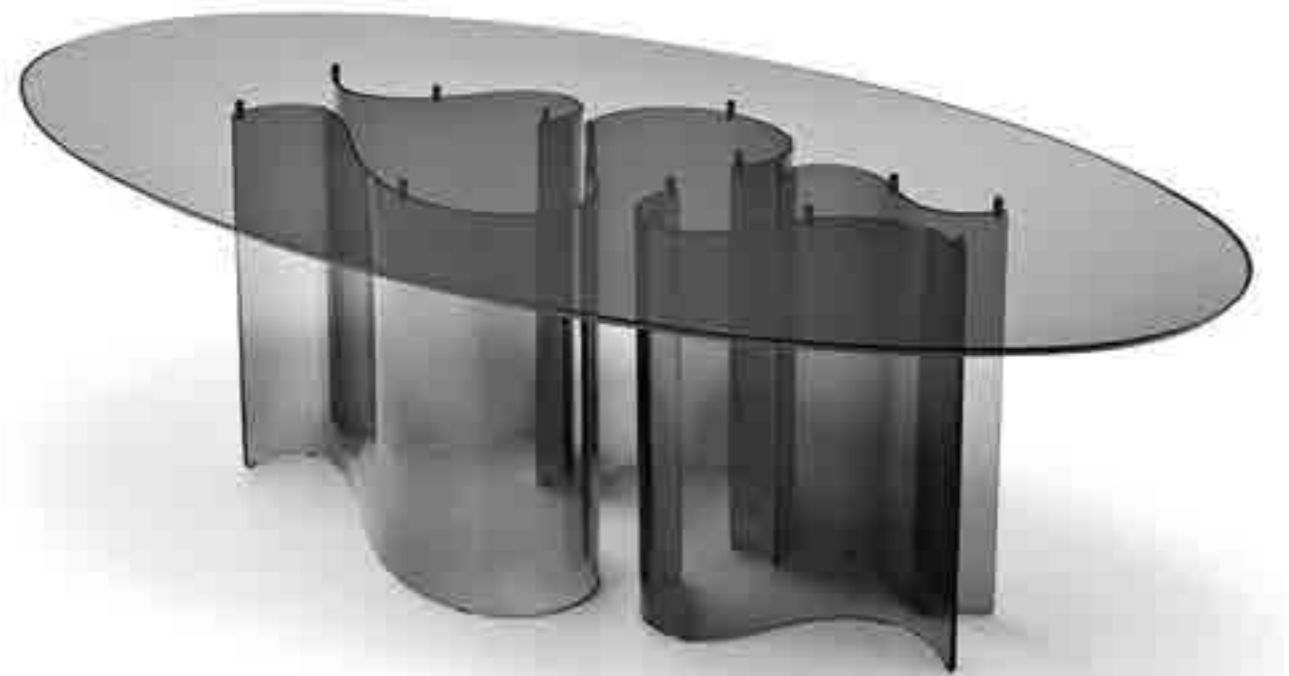

Arabesque

Tavolo con piano in vetro fumè stratificato o temperato, bisellato. Base composta da elementi in vetro fumè curvato da 10 mm. Il numero di elementi varia a seconda delle dimensioni del piano.

Table with a laminated or tempered, bevelled smoked glass top. Base consisting of 10 mm curved smoked glass elements. The number of elements varies depending on the size of the top.

Dimensioni (cm) L. P. H.
Dimensions (cm) L. W. H.

quadrato / square	rettangolare / rectangular	ellittico / elliptical
140 x 140 x 76	250 x 120 x 76	250 x 130 x 76
55 1/8" x 55 1/8" x 30"	98 7/16" x 47 1/4" x 30"	98 7/16" x 51 3/16" x 30"
	360 x 120 x 76	tondo / round
	141 3/4" x 47 1/4" x 30"	Ø 158 x 76
		Ø 62 3/16" x 30"

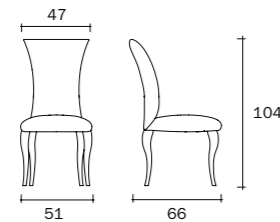

Sophia

Sedia con struttura in legno massello imbottita, rivestita in pelle o tessuto. Gambe in legno massello verniciato nero a poro aperto.

Solid wood, upholstered chair, covered with leather or fabric. Legs in solid wood, painted black open pore.

Dimensioni (cm) L. P. H.
Dimensions (cm) L. W. H.

51 x 66 x 104
20" x 25" x 41"

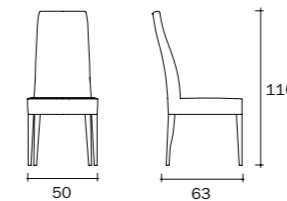

Audrey

Sedia con struttura in legno massello imbottita, rivestita in pelle o tessuto. Gambe in legno massello verniciato nero a poro aperto.

Solid wood, upholstered chair, covered with leather or fabric. Legs in solid wood, painted black open pore.

Dimensioni (cm) L. P. H.
Dimensions (cm) L. W. H.

50 x 63 x 110
19 11/16" x 24 13/16" x 43 5/16"

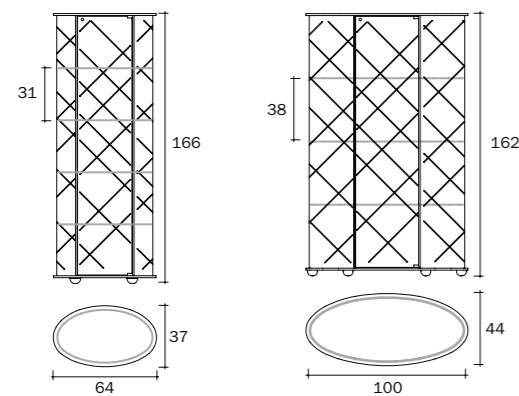

Burberry - Burberry King

Vetrina elettrificata in vetro curvato da 6 mm inciso, con quattro ripiani fissi in vetro da 6 mm. Top in vetro fumè da 12 mm, base in vetro fumè da 12 mm retroverniciato nero. Profili in alluminio verniciati nero opaco. Anta con serratura. Corpo illuminante (optional) posizionabile anche sotto il top. Corpo vetrina e ripiani disponibili in vetro fumè o bronzo.

Dimensioni (cm) L. P. H.
Dimensions (cm) L. W. H.

Wired showcase in 6 mm engraved curved glass, with four fixed 6 mm glass shelves. 12 mm smoked glass top, 12 mm smoked glass base painted black. Profiles in aluminium painted matt black. Door with lock. The optional lights can also be placed under the top. Structure and shelves available in smoked or bronze glass.

64 x 37 x 166
25 3/16" x 14 9/16" x 65 3/8"
100 x 44 x 162
39 3/8" x 17 5/16" x 63 3/4"

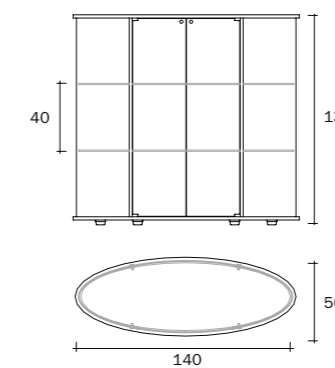

Notre Dame

Vetrina in vetro curvato da 6 mm con due ripiani fissi in vetro da 8 mm. Top e base in legno di frassino verniciato nero a poro aperto. Profili in legno verniciato nero a poro aperto. Anta con serratura. Corpo vetrina e ripiani disponibili in vetro fumè o bronzo.

Dimensioni (cm) L. P. H.
Dimensions (cm) L. W. H.

140 x 50 x 130
55 1/8" x 19 11/16" x 51 3/16"

Showcase in 6 mm curved glass with two fixed 8 mm glass shelves. Top and base made of open pore ash wood painted black. Profiles made of open pore wood painted black. Door with lock. Structure and shelves available in smoked or bronze glass.

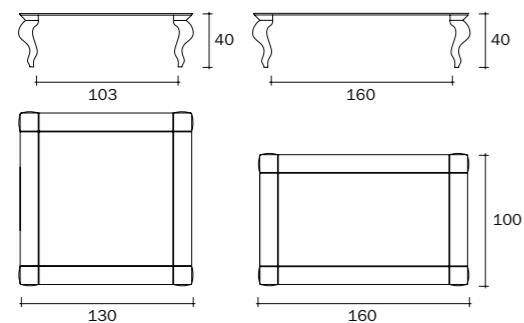

Ducale

Tavolino composto da piano in vetro fumè temperato da 12 mm, bisellato ed inciso. Gambe in resina colata verniciate nero opaco.

Dimensioni (cm) L. P. H.
Dimensions (cm) L. W. H.

Coffe table consisting of a 12 mm tempered smoked glass top, bevelled and engraved. Legs made of cast resin, painted matt black.

quadrato / square
130 x 130 x 40
51 3/16" x 51 3/16" x 15 3/4"
rettangolare / rectangular
160 x 100 x 40
62" x 39 3/8" x 15 3/4"

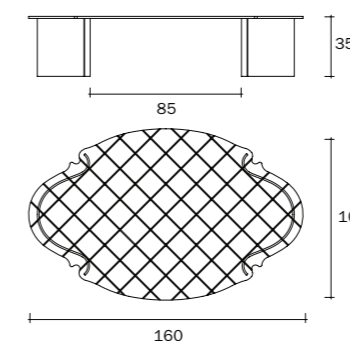
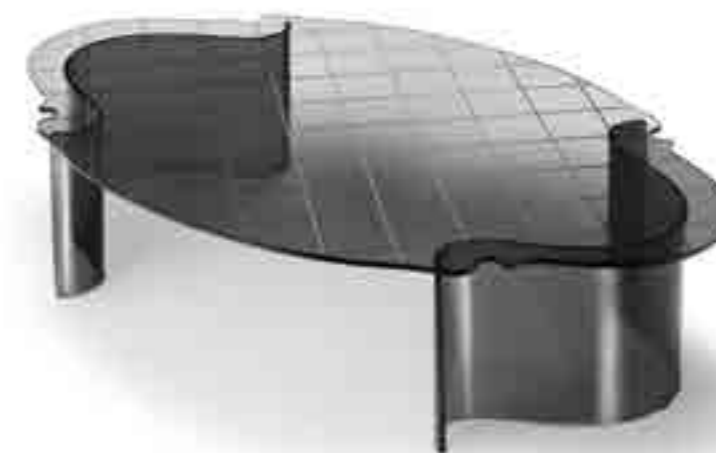

Boheme

Tavolino con piano in vetro fumè temperato da 12 mm sagomato ed inciso. Base composta da due elementi in vetro fumè curvato da 10 mm.

Dimensioni (cm) L. P. H.
Dimensions (cm) L. W. H.
160 x 100 x 35
62" x 39 3/8" x 13 3/4"

Coffee table with 12 mm tempered smoked glass top, shaped and engraved. Base consisting of two 10 mm curved smoked glass elements.

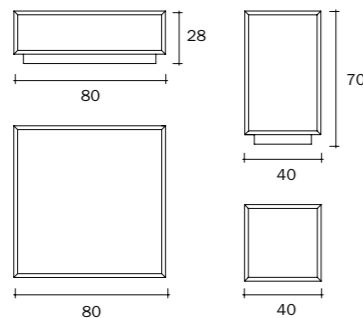

Rocks

Tavolino con struttura in fibra di legno rivestita da specchi in vetro fumè o bronzo da 5 mm molato.

Coffee table with a wood fibre structure, covered with 5 mm bevelled mirrors in smoked or bronze glass.

Dimensioni (cm) L. P.H.
Dimensions (cm) L. W. H.

80 x 80 x 28
31 1/2" x 31 1/2" x 11"

40 x 40 x 70
15 3/4" x 15 3/4" x 27 9/16"

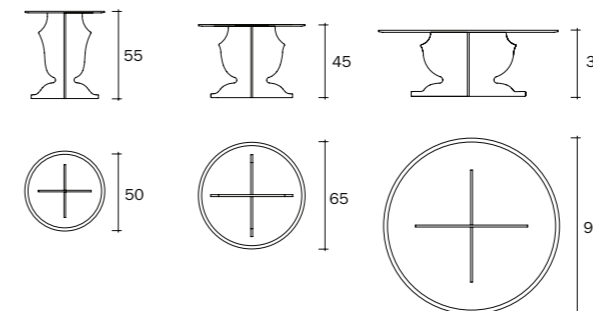

Icon

Tavolino con piano in vetro da 10mm sabbato e bisellato. Base in vetro da 10 mm sagomato ed incollato. Disponibile in vetro fumè o bronzo.

Coffee table with 10 mm sanded and beveled glass top. Base made of 10 mm shaped and glued glass. Available in smoked and bronze glass.

Dimensioni (cm) L. P.H.
Dimensions (cm) L. W. H.

Ø 50 x 55
Ø 19 11/16" x 21 5/8"
Ø 65 x 45
Ø 25 9/16" x 17 11/16"
Ø 90 x 35
Ø 35 7/16" x 13 3/4"

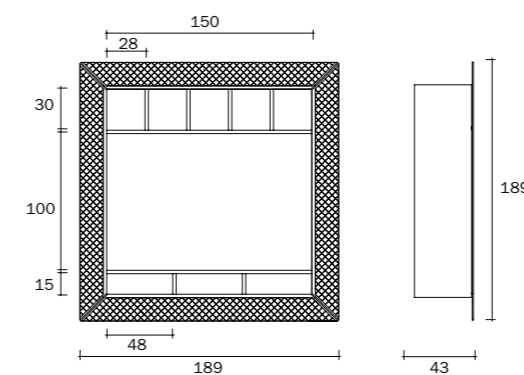

Napoleon

Mobile porta TV a parete
con cornice in vetro
Nero95 da 8mm fuso
con effetto capitonnè.
Struttura in fibra di legno
impiallacciato frassino
fiammato verniciato
nero a poro aperto.

TV wall cabinet with
a Black 95 8 mm
fused glass frame
with a quilted effect.
Structure made
of veneered ash wood
fibre, flamed and painted
black, open pore.

Dimensioni (cm) L. P.H.
Dimensions (cm) L. W. H.
189 x 43 x 189
74 7/16" x 17" x 74 7/16"



Tessuti / Fabrics

Viggo CS - Velluto / Velvet



2_Perla
Pearl

4_Tortora
Dove-Grey

6_Fango
Mud

22_Nero
Black

23_Smoke
Smoke

Honey Moon - Velluto / Velvet



1_Gesso
Chalk

11_Marmotta
Marmot

17_Polvere
Dust

19_Grigio
Grey

130_Tortora
Dove-Grey



200_Bianco
White



205_Fumo
Smoke

Si precisa che le tonalità dei colori qui riprodotti potrebbero non corrispondere fedelmente a quelle reali, per motivi dipendenti dai limiti connessi alle tecniche di stampa su carta. Per una reale valutazione, fare riferimento al campionario finiture. Please note that the colour shades reproduced here may not correspond exactly to the actual shade due to the limits in printing on paper. For a true evaluation, refer to the finish samples.

Pelli / Leathers

Nubuk - Nabuk / Nabuk



2114_Testa di moro
Brown

2215_Tortora
Dove-Grey

2116_Castagna
Chestnut

2117_Fumo
Smoke

2118_Sabbia
Sand

Zaffiro - Pelle / Leather



1112_Smoke
Smoke

1135_Grigio perla
Pearl grey

1141_Nero
Black

1181_Sabbia
Sand

1187_Testa di moro
Brown



1634_Ghiaccio
Ice



1660_Fango
Mud

Si precisa che le tonalità dei colori qui riprodotti potrebbero non corrispondere fedelmente a quelle reali, per motivi dipendenti dai limiti connessi alle tecniche di stampa su carta. Per una reale valutazione, fare riferimento al campionario finiture. Please note that the colour shades reproduced here may not correspond exactly to the actual shade due to the limits in printing on paper. For a true evaluation, refer to the finish samples.



Vetri / Glass



Fumè
Smoked

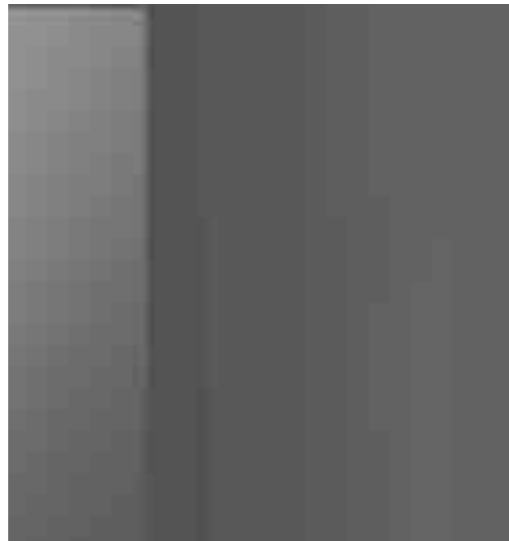

Fumè retroargentato
Back-silvered smoked



Fumè fuso retroargentato
Fused back-silvered smoked



Nero 95 Fuso
Fused Black 95



Bronzo
Bronze



Bronzo retroargentato
Back-silvered bronze



Bronzo fuso retroargentato
Fused back-silvered bronze



Frassino verniciato nero a poro aperto
Ash wood black open pore laquered

Legno / Wood

Si precisa che le tonalità dei colori qui riprodotti potrebbero non corrispondere fedelmente a quelle reali, per motivi dipendenti dai limiti connessi alle tecniche di stampa su carta. Per una reale valutazione, fare riferimento al campionario finiture. Please note that the colour shades reproduced here may not correspond exactly to the actual shade due to the limits in printing on paper. For a true evaluation, refer to the finish samples.

Si precisa che le tonalità dei colori qui riprodotti potrebbero non corrispondere fedelmente a quelle reali, per motivi dipendenti dai limiti connessi alle tecniche di stampa su carta. Per una reale valutazione, fare riferimento al campionario finiture. Please note that the colour shades reproduced here may not correspond exactly to the actual shade due to the limits in printing on paper. For a true evaluation, refer to the finish samples.



Sommario / Summary



Queen Elizabeth _ 7/88

Boiserie
Boiserie



Versailles _ 8-13 / 89

Specchi
Mirrors



New Baroque _ 14-25 / 90-91



Trinity _ 26-31 / 92-93

Consolle
Consoles



Arabesque _ 32-35 / 94



Venice _ 36-39 / 95

Tavoli
Tables



Venice _ 40-45 / 96



Cocò _ 46-53 / 97

Tavoli
Tables



Arabesque _ 54-61 / 98-99



Sedie
Seatings



Sophia _ 62-63 / 101



Audrey _ 64-65 / 100

Vetrine
Showcases



Burberry-Burberry King _ 66-67 / 102



Notre Dame _ 68-69 / 103

Tavoli bassi
Coffee tables



Ducale _ 70-71 / 104



Bohème _ 72-73 / 105



Rocks _ 74-81 / 106



Icon _ 82-83 / 107

Porta-Tv
Tv units



Napoleon _ 84-87 / 109

art direction
Marzia e Leonardo Dainelli

graphic design and layout
Acanto Comunicazione

photography and postproduction
Studio Leon

styling
Giorgia Angelini

coordination and logistics
Daniele Livi

selections
Olimpia visual plan

print and packaging
Grapho 5

Aprile 2015

credits
CECCOTTI COLLEZIONI
BAXTER
INICIPIT
BOSA
VISTOSI
ARKE TIPO

RECHERCHE ARTE
(pag 12/13 - 60/61)



Villa Miralfiore: particolare dal Salone delle feste,
medaglione con l'impresa dell'ermellino.

Villa Miralfiore: detail of Ballroom,
shield with the ermine deed.



Luxury Edition by Fiam Italia

Fiam Italia - Via Ancona 1/b - 61010 Tavullia (PU), Italia
Tel. 0039 0721 20051 - Fax: 0039 0721 202432

www.veblen.eu info@veblen.eu

Luxury Edition by Fiam Italia