

DIVANI POLTRONE TAVOLINI

DIVANI POLTRONE TAVOLINI

Photo:
Beppe Brancato
Concept image & Styling:
Alessandro Pasinelli
Styling Assistant:
Veronica Leali
Copywriter:
Francesco Cremonese
Lucia Viola Zampieri

Lithography & Printing:
Grafiche Antiga
Printed in Italy

Vieta la riproduzione a qualsiasi scopo, comprese promozionale gratuito, non destinato alla vendita - Escluso IVA Art. 2 Comma 4 D.P.R. 633/72 - Esonerato da bolli di accompagnamento Art. 4 Punto 6 D.P.R. 65/79

PIANCA

PIANCA

INDICE INDEX

Divani / Sofas	
Volo	08
Mood	20
Charme	32
Family	44
Family Plus	56
Time	68
Limbo	82
Delano	94
Duo	106
Insieme	118
Otto	132
Poltrone / Armchairs	
Dialogo	140
Isotta	146
Oplà	152
Dolcevita	158
Paesaggio	164
Tavolini / Coffee tables	
Mono	172
Abaco	174
Frame Evo	176
Icaro	178
Dedalo	180
Delano	182
Antonietta	184
Joker	186
Servogiro e Servoquadro	188
Tessuti e pelli / Fabric and leather	
Custom by Rubelli	193
Tessuti Fabric	194
Pelle e cuoio Leather and hide	200
Pelle sintetica Eco-leather	201
Cerniere e bordini Zippers and edges	202



APARTMENT



Come sospeso, si appoggia su gambe sottili, leggero allo sguardo, fiero ed elegante. La sua linea slanciata abbraccia i cuscini, partendo dagli stretti braccioli che diventano schienale. E se rivestito in pelle, conquista le cinque stelle. Per voli in prima classe e atterraggi morbidi. Divano Volo, con l'aria pulita intorno.

Almost floating on its slender legs, it looks light, proud and elegant. Its sleek lines enfold the cushions, with narrow armrests that broaden into the back. And in the leather-covered version, it truly is a five-star piece. For first-class flights and soft landings.
Volo sofa, flying high, floating on air.







Fg.10-11 | Composizione Volo ad angolo con penisola L 332x403 rivestita in pelle e corredata di cuscini in tessuto. Piedini in finitura cromo satinato. Tavolini Mono L 50 P 50 H 30 in laccato opaco Sole. Modulo a giorno People pensile in metallo verniciato opaco Nero.

Fg.12 | Composizione Volo con penisola L 332x237 rivestita in tessuto e corredata di cuscini in tessuto. Piedini in finitura cromo satinato. Tavolino Servogiro Ø 45 H 53 con struttura cromo e piano in laccato lucido spazzolato Bianco. Modulo Vision pensile in laccato opaco Mela.

Fg.13 | Dettaglio del poggiatesta addizionale.

P.10-11 | Volo corner composition with penisola W 332x403, leather-covered, with fabric cushions. Satin chrome finish feet. Mono coffee tables, W 50 D 50 H 30 in Sole matt lacquered. People wall-hanging open module in Nero matt painted metal.

P.12 | Volo composition with penisola W 332x237, fabric-covered with fabric cushions. Satin chrome finish feet. Servogiro coffee table Ø 45 H 53 with chrome structure and top in Bianco high gloss lacquered. Vision wall-hanging module in Mela matt lacquered.

P.13 | Detail of extra headrest.





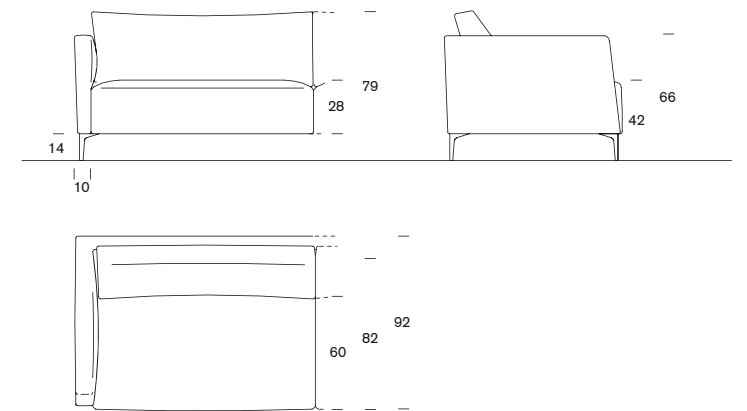

Pg.15 | Divano Volo L 250 P 92 rivestito in tessuto e corredato di cuscini in tessuto.
Poltrone Volo L 72 P 86 e pouf Volo L 92 P 92 rivestiti in tessuto, piedini in finitura cromo satinato.
Tavolino Servogiro Ø 45 H 53 con struttura cromo e piano in laccato lucido spazzolato Bianco.

Pg.16-17 | Divani Volo L 185 e 250 P 92 rivestiti in tessuto e corredati di cuscini in tessuto.
Pouf Volo L 92 P 92 rivestito in tessuto. Piedini in finitura cromo satinato.
Tavolino Servoquadro L 45 P 45 H 53 con struttura cromo e piano in laccato lucido spazzolato Sole.

P.15 | Volo sofa W 250 D 92, fabric-covered with fabric cushions.
Volo armchairs W 72 D 86 and Volo Pouf W 92 D 92, fabric-covered, feet in satin chrome finish.
Servogiro coffee table Ø 45 H 53 with chrome structure and top in Bianco high gloss lacquered.

P.16-17 | Volo Sofas W 185 and 250 D 92, fabric-covered with fabric cushions.
Volo Pouf W 92 D 92, fabric-covered. Satin chrome finish feet.
Servoquadro coffee-table W 45 D 45 H 53 with chrome structure and top in Sole high gloss lacquered.

Un fascino senza trucchi, come un volto rassicurante, bello e semplice. Con un'inclinazione dei braccioli verso l'interno che invita a lasciarsi andare, e ad abbandonarsi al soffice. Caratterizzato da due possibili confezioni, si propone in tessuto teso, o con gonna e bordino in tinta o a contrasto. Divano Mood, per ogni stato del cuore.

A guileless charm, reassuring as a warm, pretty face. The inward-sloping arms invite you to relax and sink into this softness. Dressed in two different styles, you can opt for a classic fabric covering or add a skirt and edging in matching or contrasting colours. Mood sofa, feels good, however you're feeling.







Pg.22-23 | Composizione Mood con penisola L 284 P 226 rivestita con confezione tesa in pelle e corredata di cuscini rivestiti in tessuto. Moduli Spazio a terra e penzili in laccato opaco Bianco e Nero.

P.22-23 | Mood composition with penisola W 284 D 226, leather covered with fabric covered cushions. Floor-standing and wall-hanging Spazio modules in Bianco and Nero matt lacquered.

Pg.24 | Composizione Mood con penisola L 333 P 96 rivestita con confezione con gonna in tessuto e corredata di cuscini in tessuto. Tavolino Abaco Ø 60 H 45 con struttura cromo e piano in laccato opaco Prato.

P.24 | Mood composition with penisola W 333 D 96, fabric covering with skirt and fabric cushions. Abaco coffee table Ø 60 H 45 with chrome structure and top in Prato matt lacquered.

Pg.25 | Dettaglio del poggiatesta addizionale.

P.25 | Detail of extra headrest.





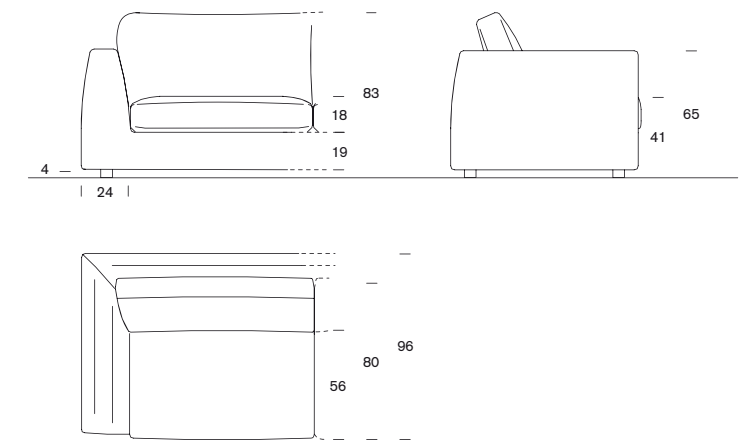

Pg.27 e 30 | Composizione Mood ad angolo L 304x304 rivestita con confezione con gonna in tessuto e corredata di cuscini in tessuto. Tavolini Abaco Ø 76 H 30 e Ø 90 H 18 con struttura e piano laccato opaco Bianco. Moduli Spazio pensili in laccato opaco Bianco.

Pg.28-29 | Divano Mood L 228 P 96 rivestito con confezione tesa in tessuto e corredata di cuscini in tessuto. Poltrona Dialogo L 84 P 98 rivestita in tessuto. Madia Contemporanea in laccato lucido spazzolato Petrolio con maniglia in tinta.

P.27 and 30 | Mood corner composition W 304x304, fabric covering with skirt and fabric cushions. Abaco coffee tables Ø 76 H 30 and Ø 90 H 18 with structure and top in Bianco matt lacquered. Wall-hanging Spazio modules in Bianco matt lacquered.

P.28-29 | Mood sofa W 228 D 96 fabric covered with fabric cushions. Dialogo armchair W 84 D 98, fabric covered. Madia Contemporanea in Petrolio high gloss lacquered with matching handle.

CHARME

Braccioli straordinariamente accoglienti grazie a morbide rotondità interne. Doppia profondità di seduta, comfort superiore o gradevoli conversazioni? Scegliete voi. La bicromia tra bordino e rivestimento raffina lo stile, in vista di incontri importanti. Divano Charme, fascino che nutre gli occhi.

Its soft, rounded armrests are extraordinarily cosy. Double-depth seats, superior comfort or pleasant conversations? It's your choice. The contrasting between edge and covering lends refinement, ready for important encounters. Charme sofa, easy on the eye.







Pg.34-35 | Composizione
 Charme ad angolo L 351 P 327
 rivestita in tessuto con bor-
 dino in contrasto e corredata
 di cuscini in tessuto.
 Basamenti in verniciato opaco
 Bianco.
 Tavolino Frame Evo L 132 P 71
 H 18 con struttura verniciata
 e piano in vetro lucido Nero.
 Moduli Spazio pensili in lac-
 cato opaco Bianco e Nero.

P.34-35 | Charme corner com-
 position W 351 D 327, fabric
 covered with contrasting
 edging and fabric cushions.
 Base structure in Bianco matt
 lacquered.
 Frame Evo coffee table W 132
 D 71 H 18 with painted struc-
 ture and top in Nero high
 gloss glass lacquered.
 Wall-hanging Spazio modules
 in Bianco and Nero matt lac-
 quered.







PROFONDITÀ 96 CM / 96 CM DEPTH

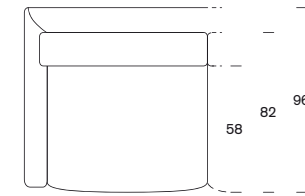
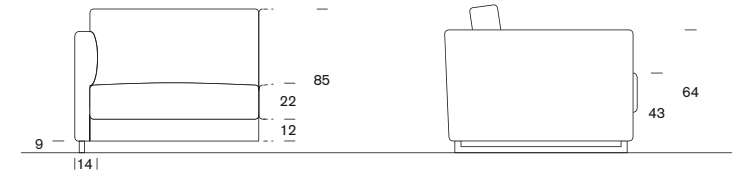

PROFONDITÀ 120 CM / 120 CM DEPTH

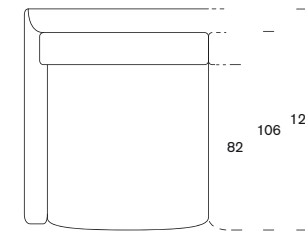
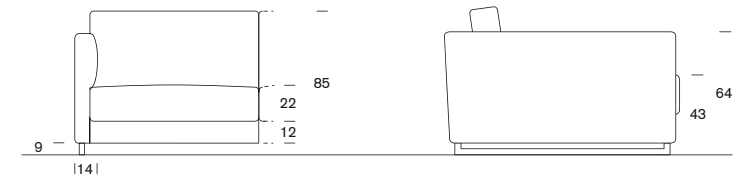

Eg.40-41 | Divano Charme
L 240 P 120 rivestito in tessuto e corredato di cuscini in tessuto.
Basamenti in verniciato opaco Caffè.
Modulo People a terra in laccato lucido spazzolato Tortora.

P.40-41 | Charme sofa W 240 D 120, fabric covered with fabric cushions.
Base structure in Caffè matt lacquered.
Floor-standing People module in Tortora high gloss lacquered.

Un design che esprime certezze e assicura affidabilità, donando sicurezza. Prende forma grazie a moduli, cuscini e schienali sicuri, sostenuti da stabili basamenti in essenza o metallo cromato. Estratto il letto, si fa accogliente con ogni ospite inaspettato.
Divano Family, congratulazioni meritate.

A design that exudes certainty and reliability, a sense of security. It is formed of modules, strong backrests and cushions, supported by sturdy wood or chrome bases. Simply pull out the bed to welcome any unexpected guests.
Family sofa, a commendable couch.







Pg.46-47 | Divano Family
L 232 P 95 rivestito in tessuto e corredato di cuscini in tessuto.
Poltrona Family L 88 P 83 rivestita in tessuto.
Piedi in Rovere Grigio.
Moduli Spazio pensili in laccato opaco Ciclamino e Violetto.
Tavolino Antonietta L 38 P 38 H 45 verniciato Bianco.

Pg.48 | Poltrona Family L 88 P 83 rivestita in tessuto.
Piedi in Rovere Grigio.
Tavolino Antonietta L 38 P 38 H 45 verniciato Bianco.

P.46-47 | Family sofa W 232 D 95, fabric covered with fabric cushions.
Family armchair W 88 D 83, fabric covered. Feet in Rovere Grigio.
Wall-hanging Spazio modules in Ciclamino and Violetto matt lacquered.
Antonietta coffee table W 38 D 38 H 45 painted Bianco.

P.48 | Family armchair W 88 D 83, fabric covered.
Feet in Rovere Grigio.
Antonietta coffee table W 38 D 38 H 45 painted Bianco.





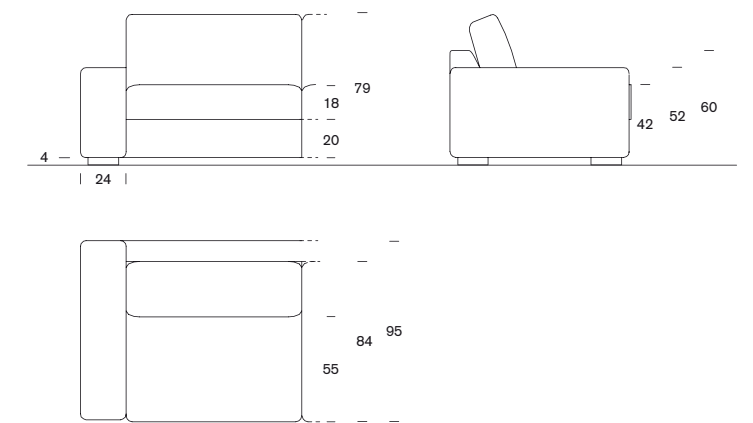

Pg.52-53 | Composizione Family L 283 e 208 P 95 rivestita in tessuto e corredata di cuscini in tessuto. Piedi in finitura cromo. Tavolino Joker L 90 P 90 H 12 in laccato opaco Bianco. Moduli Spazio a terra e pensili in laccato opaco Bianco.

P.52-53 | Family composition W 283 and 208 D 95, fabric covered, with fabric covered cushions. Feet in chrome finish. Joker coffee table W 90 D 90 H 12 in Bianco matt lacquered. Floor-standing and wall-hanging Spazio modules in Bianco matt lacquered.

FAMILY PLUS

Un restyle che parte da un punto ben saldo e volge il suo sguardo avanti, per continuare a stupire. Con i bordini rifiniti e i braccioli più alti e fascianti, alza il tiro, e raggiunge la massima espressione rivestito di raffinata pelle, meritandosi la lode.

Divano Family Plus, addizione contemporanea.

A restyle that sets out from solid roots and looks ahead, ready to amaze you once more. With its neat edging and its higher, cosier armrests, it sets its sights higher, achieving its ultimate expression when elegantly covered with leather, and glory. Family Plus sofa, a contemporary addition.







Fg.60 | Composizione Family Plus con chaise longue L 314 P 185 rivestita in pelle e corredata di cuscini in tessuto. Piedi a scomparsa. Tavolino Servogiro Ø 45 H 53 con struttura cromo e piano in laccato lucido spazzolato Bianco.

P.60 | Family Plus composition with chaise longue W 314 D 185, leather-covered with fabric cushions. Hidden feet. Servogiro coffee table Ø 45 H 53 with chrome structure and top in Bianco high gloss lacquered.





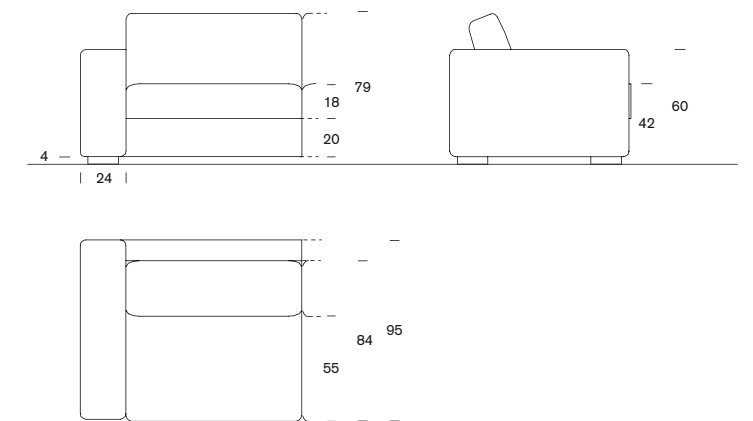

P.63 | Family Plus sofa
W 232 D 95, fabric covered
with fabric cushions.
Hidden feet.
Family Plus Pouf W 95 D 95,
fabric covered.
Madia Quadra in laccato opa-
co Prato.

Pg.63 | Divano Family Plus
L 232 P 95 rivestito in tes-
suto e corredato di cuscini
in tessuto. Piedi a scom-
parsa.
Pouf Family Plus L 95 P 95
rivestito in tessuto.
Madia Quadra in laccato opa-
co Prato.

L'ora giusta per il relax la decidete voi.
La seduta è come scivolata al suo posto
tra i comodi braccioli inclinati, e a
sostenerla una struttura sospesa da terra,
poggiata ai lati su piedi a ponte. Stabile
negli anni per uno stile senza tempo.
Divano Time, ogni giorno, tutti i giorni.

You decide when it's the right time for
relaxation. The seat seems to have slid
in between the comfortable sloping arms,
standing on a raised structure with bridged
feet on either side. Built to last, for a
timeless style.
Time sofa, any day, every day.





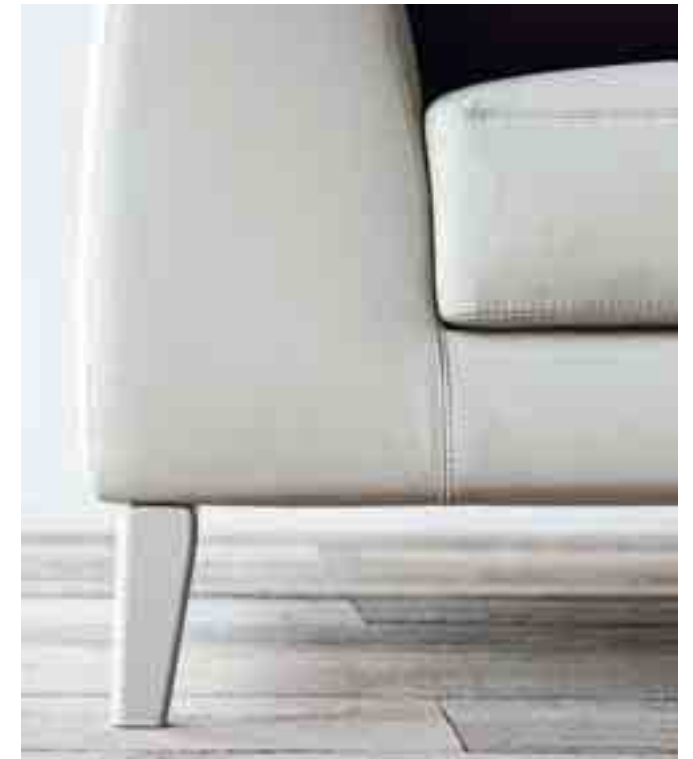

Pg.70-71 | Composizione Time L 304 P 96 e divano Time L 208 P 96 rivestiti in tessuto e corredati di cuscini in tessuto. Basamenti in Rovere Grigio. Tavolino Joker L 91 P 91 H 13 rivestito in pietra Multicolor. Modulo a giorno People pensile in metallo verniciato opaco Nero.

Pg.72 | Composizione con chaise longue Time L 314 P 152 rivestita in tessuto e corredata di cuscini in tessuto. Basamenti in Rovere Grigio. Tavolini Mono L 50 P 50 H 30 in laccato opaco Prugna. Modulo Spazio pensile in laccato opaco Nero.

P.70-71 | Time composition W 304 D 96 and Time sofa W 208 D 96, fabric covered with fabric cushions. Base structure in Rovere Grigio. Tavolino Joker W 91 D 91 H 13 covered in Multicolor stone. People wall-hanging open module in Nero matt painted metal.

P.72 | Time composition with chaise longue W 314 D 152, fabric covered with fabric cushions. Base structure in Rovere Grigio. Mono coffee tables, W 50 D 50 H 30 in Prugna matt lacquered. Wall-hanging Spazio module in Nero matt lacquered.





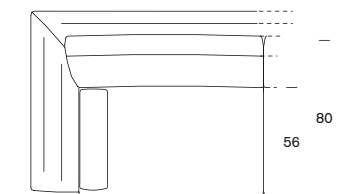
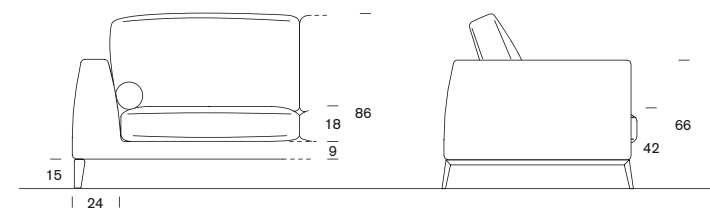

Pg.75 | Poltrona Time L 92 P 86 rivestita in tessuto. Basamenti in laccato opaco Petrolio. Tavolino Abaco Ø 60 H 45 con struttura nera e piano laccato opaco Prugna.

P.75 | Time armchair W 92 D 86, fabric covered. Base structure in Petrolio matt lacquered. Abaco coffee table Ø 60 H 45 with black structure and top in Prugna matt lacquered.

Pg.76-77 | Composizione con penisola Time L 304 P 206 rivestita in tessuto e corredata di cuscini in tessuto. Basamenti in rovere naturale. Tavolini Mono L 100 P 100 H 20 e L 50 P 50 H 30 in laccato opaco Bianco. Modulo Spazio pensile in laccato opaco Sole.

P.76-77 | Time composition with penisola W 304 D 206, fabric covered with fabric cushions. Base structure in natural oak. Mono coffee tables W 100 D 100 H 20 and W 50 D 50 H 30 in Bianco matt lacquered. Wall-hanging Spazio modules in Sole matt lacquered.

Pg.78 | Divano Time L 288 P 96 rivestito in pelle e corredato di cuscini in tessuto. Basamenti in laccato opaco Tortora. Poltrona Time L 92 P 86 rivestita in tessuto. Basamenti in laccato opaco Petrolio. Moduli Spazio pensili in laccato opaco Bianco.

P.78 | Time sofa W 288 D 96, leather covered with fabric cushions. Base structure in Tortora matt lacquered. Time armchair W 92 D 86, fabric covered. Base structure in Petrolio matt lacquered. Wall-hanging Spazio module in Bianco matt lacquered.

STUDIO



Sistema di divani in leggero e maneggevole polistirolo, privo di strutture fisse e rigide. Dinamico e giovane nel creare soluzioni di living inaspettate e informali. Facile nell'offrire la possibilità di unire i moduli tramite cerniere e ganci. Moderno e giocoso nel contrasto cromatico tra bordini e forme. Divano Limbo, musica per corpi liberi.

A sofa system in light, malleable polystyrene, free of all fixed and rigid structures. Dynamic and youthful, it creates unexpected, informal living solutions. With easily-combined units using zips and hooks. Modern and playful with colour contrasts between edging and volumes. Limbo sofa, music for lithe bodies.







Fg.83 | Elemento centrale Limbo con funzione di poltrona L 83 P 90 e pouf Limbo L 83 P 58, entrambi rivestiti in pelle.
Tavolino Antonietta L 38 P 38 H 45 verniciato Bianco.

P.83 | Limbo central element with armchair function W 83 D 90 and Limbo pouf W 83 D 58, both leather-covered.
Antonietta coffee table W 38 D 38 H 45 painted Bianco.

Fg.84-85 | Elementi centrali Limbo con funzione di poltrona L 83 P 90 e pouf Limbo L 83 P 58, tutti rivestiti in tessuto.
Divano Limbo due posti L 230 P 90 rivestito in pelle.
Tavolino Servoquadro L 45 P 45 H 53 con struttura cromo e piano in laccato lucido spazzolato Nero.
Tavolino Servogiro Ø 45 H 53 con struttura cromo e piano in laccato lucido spazzolato Bianco.

P.84-85 | Limbo central elements with armchair function W 83 D 90 and Limbo pouf W 83 D 58, both leather-covered.
Limbo two-seat sofa W 230 D 90 H 73, leather-covered.
Servoquadro coffee table W 45 D 45 H 53 with chrome structure and top in Nero high gloss lacquered.
Servogiro coffee table Ø 45 H 53 with chrome structure and top in Bianco high gloss lacquered.

Fg.86 | Composizione Limbo L 263 P 90 rivestita in tessuto.
Tavolini Joker L 90 P 90 H 12 in laccato opaco Bianco.

P.86 | Limbo composition W 263 D 90, fabric covered.
Joker coffee tables W 90 D 90 H 12 in Bianco matt lacquered.



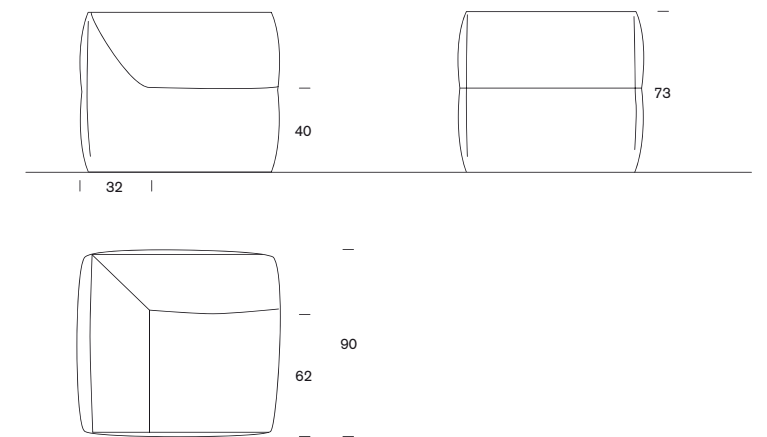

Pg.89 | Elemento centrale Limbo con funzione di poltrona L 83 P 90 e pouf Limbo L 83 P 58, entrambi rivestiti in tessuto.

P.89 | Limbo central element with armchair function W 83 D 90 and Limbo pouf W 83 D 58, both leather-covered.

Pg.90-91 | Composizione Limbo L 346x263 P 90 rivestita in tessuto e corredata di cuscini in tessuto.

P.90-91 | Limbo composition W 346x263 D 90, fabric covered with fabric cushions.

Pg.92 | Chaise longue Limbo L 83 P 160 rivestita in tessuto. Pouf Limbo Ø 58 e Ø 90 rivestiti in tessuto.

P.92 | Limbo chaise longue W 83 D 160, fabric covered. Limbo Pouf Ø 58 and Ø 90, fabric covered.

I due livelli degli schienali ne movimentano il disegno e lo spazio, mentre la pedana minimale sostiene gli ampi cuscini di seduta, per accogliere dolcemente come se fosse la prima volta. In questo caso la si potrà anche scordare: quella dopo sarà bella uguale. Divano Delano, comfort costante.

The split-level backrests give a sense of movement, while the minimal base supports the large seat cushions, to welcome softly, as if it were the first time. But even if you forget it, the next time will be just as beautiful. Delano sofa, constant comfort.







Pg.95 | Dettaglio della libreria uso bracciolo.

Pg.96-97 | Composizione Delano L 429 P 99 rivestita in tessuto e corredata di cuscini in tessuto, libreria con tavolino uso bracciolo in laccato opaco Tortora. Tavolino Servoquadro L 45 P 45 H 53 in laccato lucido Nero. Moduli Spazio pensili in laccato opaco Petrolio.

Pg.98 | Divano Delano con schienale basso L 330 P 99 rivestito in tessuto e corredata di cuscini in tessuto. Pouf Delano L 99x99 rivestito in pelle.

P.95 | Detail of armrest-bookcase.

P.96-97 | Delano composition W 429 D 99, fabric covered with fabric cushions, bookcase with armrest-table in Tortora matt lacquered. Servoquadro coffee table W 45 D 45 H 53 in Nero high gloss lacquered. Wall-hanging Spazio modules in matt lacquered Petrolio.

P.98 | Delano sofa with low back W 330 D 99, fabric covered with fabric cushions. Delano pouf W 99x99, leather-covered.



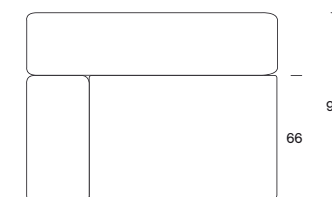
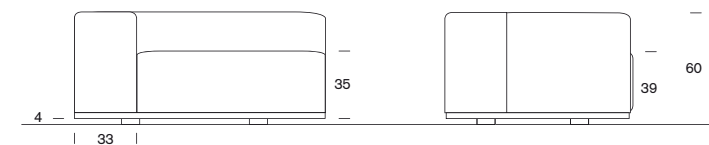
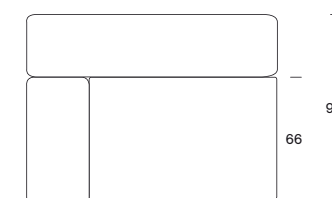
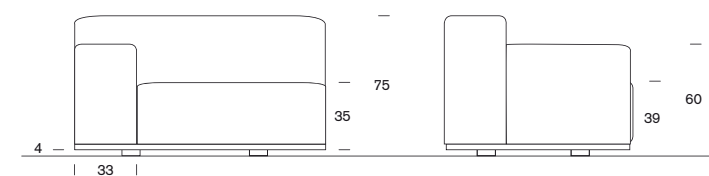

**SCHIENALE BASSO****SCHIENALE ALTO**Pg.101 | Dettaglio cuscina-
tura.

P.101 | Detail of cushions.

Pg.102-103 | Composizione Delano ad angolo con schienali alti e bassi L 396x363 P 99, rivestita in tessuto e corredata di cuscini in tessuto.
Tavolino Frame Evo L 132 P 71 H 30 con struttura verniciata e piani in vetro Nero.

P.102-103 | Delano corner composition with high and low backs W 396x363 D 99, fabric covered with fabric cushions.
Frame Evo coffee table W 132 D 71 H 30 with painted structure and tops in Nero glass.

Pg.104 | Composizione Delano L 330 P 165 con chaise longue e pouf rivestiti in pelle, corredata di cuscini in pelle.
Tavolino Dedalo L 98 P 98 H 25 con cassetto in laccato Bianco lucido.

P.104 | Delano composition W 330 D 165 with leather-covered chaise longue and pouf, and leather cushions.
Dedalo coffee table W 98 D 98 H 25 with drawers in Bianco high gloss lacquered.

L'ampia e sottile seduta in piuma viene accolta nel corpo del divano, donando a quel comfort assoluto uno spessore visivo esile e leggero. Tra doppi schienali fissi o reclinabili, due diversi braccioli possibili, e la sua vastissima modularità, permette di soddisfare ogni esigenza, con grazia.
Divano Duo, tutte le misure dell'eleganza.

The large, thin feather cushion is incorporated into the body of the sofa, combining that absolute comfort with a light, slender visual impact. With double fixed or reclining backs, a choice of two different armrests and a wide range of modular options, it can satisfy all requirements, with grace.
Duo sofa, elegance in all sizes.







Pg.107 | Particolare dello schienale nelle due posizioni.

P.107 | Detail of back in its two positions.

Pg.108-109 | Divani Duo L 260 (braccioli L 30) e L 240 (braccioli L 20), con schienale abbassato P 100, con schienale alzato P 108, rivestiti in tessuto e corredati di cuscini in tessuto.

P.108-109 | Duo sofas W 260 (armrests W 30) and W 240 (armrests W 20), lowered backrest position D 100, raised backrest position D 108, fabric covered with fabric cushions.

Pg.110 | Divano Duo con schienale fisso L 280 P 100, rivestito in tessuto e corredato di cuscino in tessuto. Pouf Duo L 100 P 100 rivestito in tessuto.

P.110 | Duo sofa with fixed backrest W 280 D 100, fabric covered with fabric cushions. Duo pouf W 100 D 100 fabric covered.



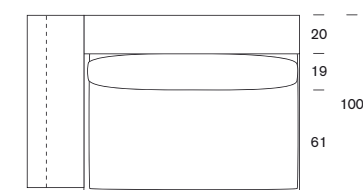
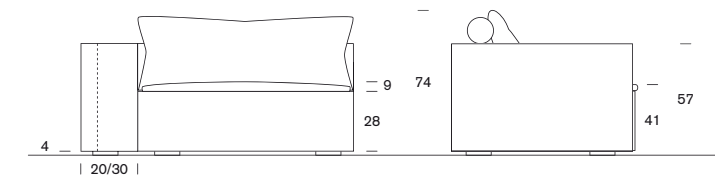
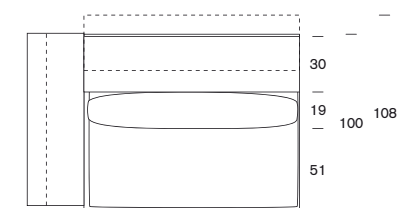
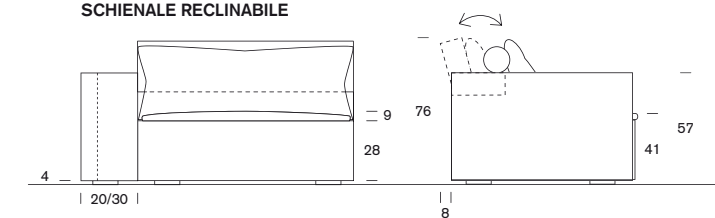

**SCHIENALE FISSO****SCHIENALE RECLINABILE**

Pg.113 | Dettaglio del bracciolo.

P.113 | Detail of armrest.

Pg.114-115 | Composizione Duo con schienali reclinabili e schienali fissi L 440/448 x L 350 P 100/108, rivestita in tessuto e corredata di cuscini in tessuto. Basamento cromo.

Tavolini Joker in laccato opaco Bianco L 135 P 65 H 12. Composizione di mensole Mp3.

P.114-115 | Duo composition with reclining and fixed backs W 440/448 x W 350 D 100/108, fabric covered with fabric cushions. Base structure in chrome finish.

Joker coffee tables in Bianco matt lacquered W 135 D 65 H 12. Composition of Mp3 shelves.

Pg.116 | Sacca portaoggetti in pelle in appoggio sul bracciolo, cuscino schienale con rullo.

P.116 | Leather sofa tidy hangs on armrest, backrest cushion with roll.

Un divano davvero componibile, con elementi indipendenti e insoliti. Essenziale nel design ed estroso nella modularità, con uno stile nitido o stravagante e pouf di ogni tipo. Coniugabile con la praticità di una libreria/contenitore, accoglie ogni estensione di te.
Divano Insieme, fantasia a portata di mano.

A truly modular sofa, with striking, independent elements. Essential design and creative modularity, with a clear, distinctive style and poufs of all sorts. Combined with the pragmatism of a bookshelf/storage unit, it is a welcoming extension of yourself.
Insieme sofa, keeping your imagination handy.



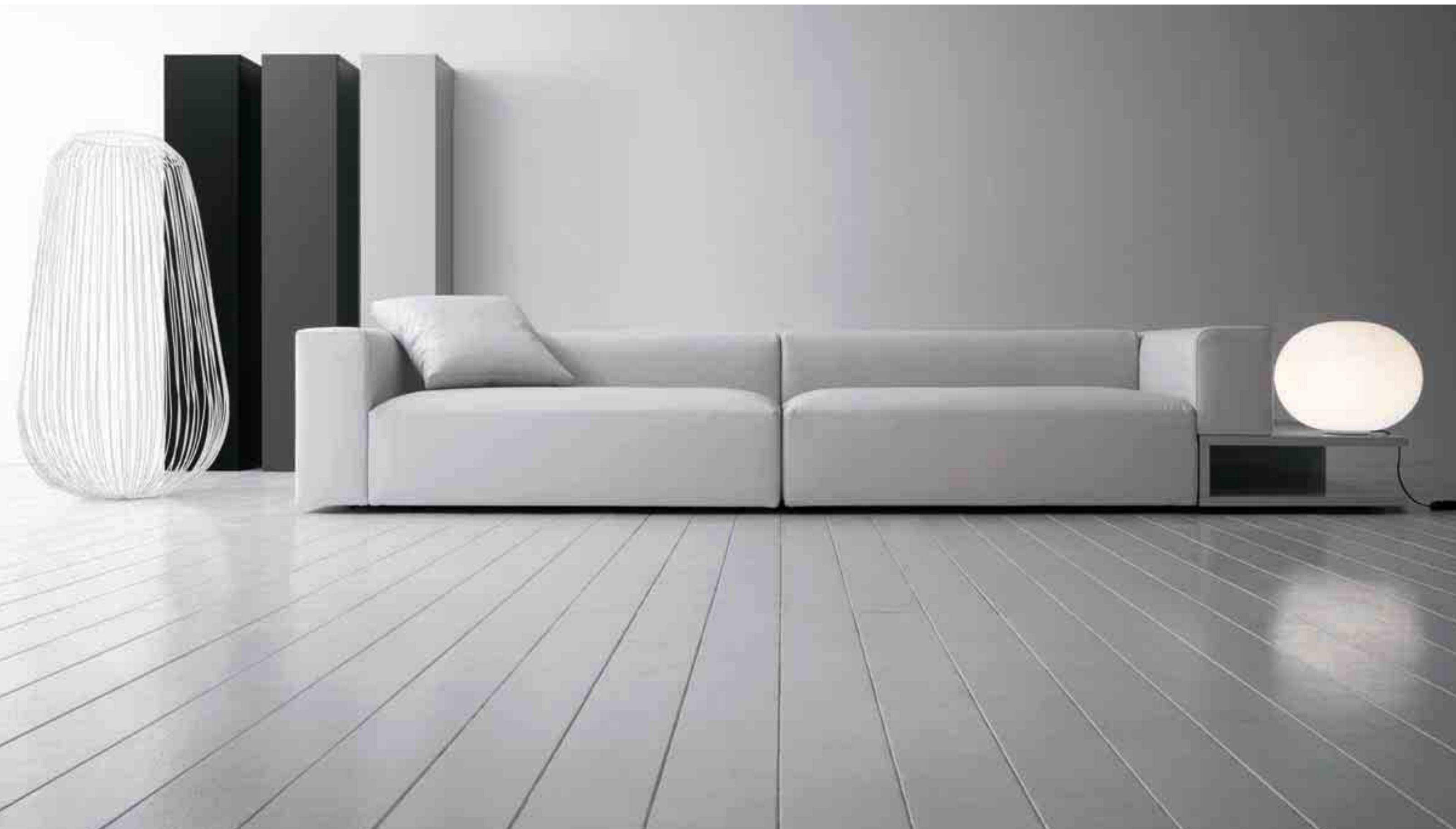



Pg.119 | Composizione Insieme L 201 P 98 rivestita in tessuto e corredata di cuscini con e senza rullo in tessuto. Pouf Insieme anteriore L 131 P 45 rivestito in tessuto.

P.119 | Insieme composition W 201 D 98 fabric covered with fabric cushions with and without roll. Insieme front pouf W 131 D 45 fabric covered.

Pg.120-121 | Composizione Insieme & People L 352 P 125 rivestita in pelle e corredata di cuscino in pelle, con moduli People in laccato lucido spazzolato Bianco. Composizione di moduli Spazio a terra in laccato opaco Bianco, Grigio scuro e Nero.

P.120-121 | Insieme & People composition W 352 D 125, leather-covered with leather cushion, with People modules in Bianco high gloss lacquered. Floor-standing composition of Spazio modules in Bianco, Grigio scuro and Nero matt lacquered.

Pg.122 | Composizione Insieme & People L 327 P 125 rivestita in pelle e corredata di cuscini in pelle. Moduli People in laccato lucido spazzolato Bianco.

P.122-327 | Insieme & People composition W 327 D 125, leather-covered with leather cushions. People modules in Bianco high gloss lacquered.

Pg.123 | Composizione di pouf con forme sagomate e di varie dimensioni, rivestiti in tessuto. Tavolino Antonietta L 38 P 38 H 45 in metallo verniciato Nero.

P.123 | Composition of asymmetrical-shaped poufs of various sizes, fabric covered. Antonietta coffee table W 38 D 38 H 45 in Nero painted metal.









SEDUTA LINEARE

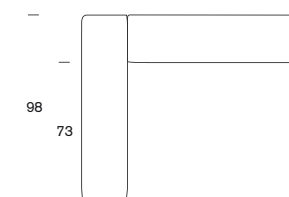
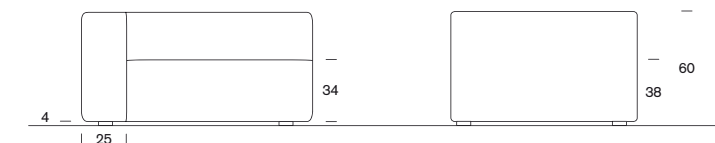

SEDUTA SAGOMATA

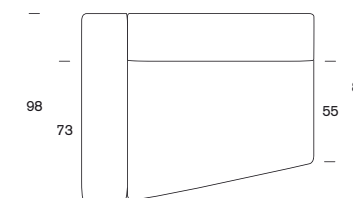
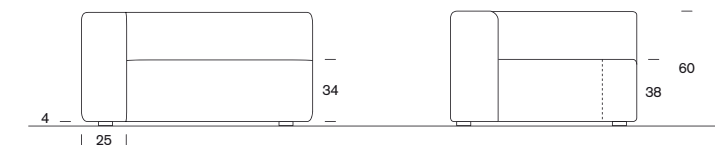

Pg.124-125 | Composizione Insieme L 400 P 98 rivestita in tessuto e corredata di cuscini in tessuto. Composizione di moduli a giorno People in metallo verniciato Bianco.

P.124-125 | Insieme composizione W 400 D 98, fabric covered with fabric cushions. Composition of People open modules in Bianco painted metal.

Pg.127 | Dettaglio del modulo People in laccato lucido spazzolato Nero.

P.127 | Detail of the People module in Nero high gloss lacquered.

Pg.128-129 | Composizione Insieme L 344 P 98 rivestita in tessuto e corredata di cuscini in tessuto. Composizione Spazio moduli in laccato opaco Sole.

P.128-129 | Insieme composizione W 344 D 98, fabric covered with fabric cushions. Composition of Spazio modules in Sole matt lacquered.

Pg.130 | Dettaglio della libreria ad angolo e del modulo People in laccato lucido spazzolato Bianco.

P.130 | Detail of the corner bookcase and People module in Bianco high gloss lacquered.

Un divano profondo e importante, un naturale elemento centrale di arredo. Una lieve curva muove lo schienale, distanziandolo dalle pareti e ampliando le dimensioni della seduta. Una cascata di cuscini ne completano il design. Disponibile anche in versione poltrona. Divano Otto, lo spazio che serve.

A large, deep sofa, which naturally forms a central element in any setting. The back curves gently, setting it away from the walls and enlarging the seat. A cascade of cushions completes the design. Also available as an armchair. Otto sofa, all the space you need.

Design: Aldo Cibic.





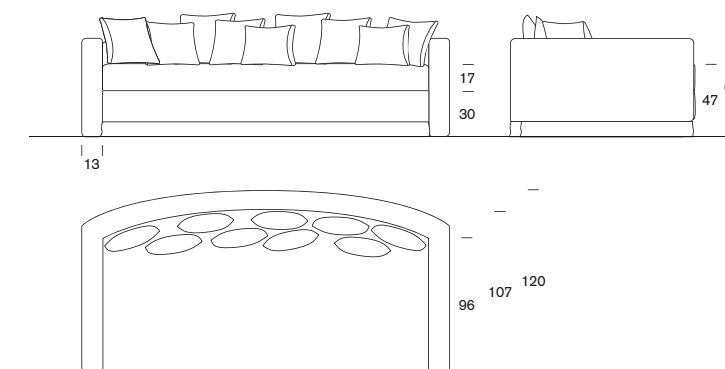

Fg.134-135 | Divano Otto
L 240 P 120 rivestito in tessuto e corredato di cuscini di schienale in dotazione in tessuto.
Tavolini Antonietta L 38 P 38 H 45 in metallo verniciato Bianco.

P.134-135 | Otto sofa W 240 D 120, fabric covered with back fabric cushions supplied.
Antonietta coffee tables W 38 D 38 H 45 in Bianco painted metal.

Fg.136 | Poltrona Otto L 120 P 120 rivestita in tessuto corredata di cuscini di schienale in dotazione in tessuto.

P.136 | Otto armchair W 240 D 120, fabric covered with back fabric cushions supplied.

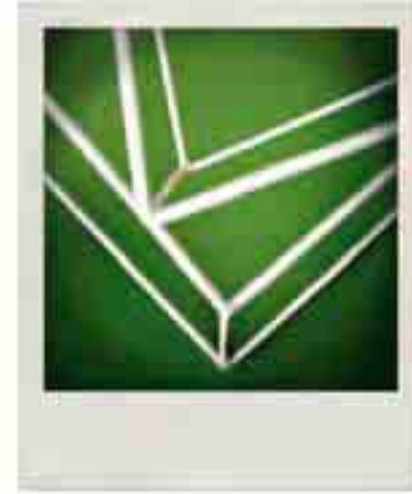

DIALOGO

Lo schienale alto invita a lasciarsi alle spalle le preoccupazioni quotidiane, a concedersi il comfort tattile del tessuto, o ad accarezzare l'abbondanza di morbida pelle. Esteticamente composta, comunica senza invadenza, parlando chiaro, ma solo con il suo stile, impeccabile. Poltrona Dialogo, le parole vengono dopo.

The high back invites you to leave the day's worries behind you and sink into the tactile comfort of the fabric, or caress the abundance of soft leather. Aesthetically sedate, it communicates without intruding, speaking volumes through its impeccable style. Dialogo armchair, words can wait.







Pg.141 | Poltrona Dialogo
L 84 P 98 rivestita in pelle
e corredata di cuscino in
tessuto.
Tavolino Mono L 30 P 30 H 50
verniciato opaco Bianco.

P.141 | Dialogo armchair
W 84 D 98, leather-covered
with fabric cushion.
Mono coffee tables W 30 D 30
H 50 in Bianco matt painted.

Pg.142-143 | Poltrona Dialo-
go L 84 P 98 rivestita in
tessuto e corredata di cusci-
no in tessuto, pouf Dialogo
L 68 P 56 rivestito in tes-
suto.

P.142-143 | Dialogo armchair
W 84 D 98 fabric covered
with fabric cushion and Dia-
logo pouf W 68 D 56 fabric
covered.

Pg.144 | Poltrona Dialogo
L 84 P 98 rivestita in tes-
suto, pouf Dialogo L 68 P 56
rivestito in tessuto.

P.144-143 | Dialogo armchair
W 84 D 98 fabric covered,
Dialogo pouf W 68 D 56 fa-
bric covered.

La struttura in frassino naturale o laccata nei colori della collezione, disegna una silhouette essenziale e neutra. È la seduta a definire lo stile, che nelle diverse versioni può cambiare totalmente: austera e vintage se in cuoio, giovane e fresca se in tessuto trapuntato. Per serate di gala e giornate di sole. Poltrona Isotta, architettata per i lieti fini.

The frame, in natural ash wood or lacquered in the colors of the collection, traces an essential, neutral silhouette. The style is defined by the seat, changing completely according to the version: austere and vintage in leather, fresh and youthful in padded fabric. For gala evenings and sunny days. Isotta armchair, designed for happy endings.







Pg.148-149 | Poltrone Isotta
L 75 P 80 con rivestimento
in tessuto trapuntato e con
rivestimento in cuoio.
Moduli a giorno Spazio in
laccato opaco Sole.

P.148-149 | Isotta armchairs
W 75 D 80 with quilted
fabric covering, and with
leather covering. Spazio
open modules in Sole matt
lacquered.

Come un tulipano schiuso, la struttura raccoglie il meglio di una seduta subito confortevole. Grazie al basamento girevole può girare su se stessa, per seguire facilmente la luce e il movimento attorno. Poltrona Oplà, fiore di casa.

Like an open tulip, its shape offers the best of an immediately comfortable seat. With its rotating base, it can spin around, easily following the light and movement around it.
Oplà armchair, a flower for your home.







Fg.154-155 | Poltrona Oplà Ø 70 rivestita in tessuto bicolore.
Composizione Spazio Moduli in laccato opaco Bianco.

Fg.156 | Poltrona Oplà Ø 70 rivestita in tessuto e corredata di cuscino in tessuto.
Moduli Spazio pensili con ante battenti e top in laccato opaco e lucido spazzolato Bosco.

P.154-155 | Oplà armchair Ø 70 two-color fabric covered.
Composition of Spazio modules in Bianco matt lacquered.

P.156 | Oplà armchair Ø 70 fabric covered with fabric cushion.
Wall-hanging Spazio modules with wing doors and top in Bosco matt and high gloss lacquered.

DOLCEVITA

Ospitale e generosa nelle forme arrotondate dei braccioli e dello schienale, contiene un cuscino di seduta alto e sensuale. Si protende verso l'alto sospesa sopra un basamento girevole cromato e lucido. Poltrona DolceVita, da vivere così.

The generous, welcoming, rounded forms of the arms and back surround a high, sensual seat cushion. It reaches upwards, suspended on a shiny, chrome-plated rotating base. DolceVita armchair, live it like it is.







Fg.160-161 | Poltrone Dolcevita L 74 P 76 rivestite in tessuto.
Moduli Spazio in laccato lucido spazzolato Bianco e mensola laccato opaco Nero.

Fg.162 | Poltrona Dolcevita L 74 P 76 rivestita in tessuto e corredata di cuscino in tessuto.
Moduli People a terra in laccato lucido spazzolato Creta.

P.160-161 | Dolcevita armchairs W 74 D 76, fabric covered.
Spazio modules in Bianco high gloss lacquered and Nero matt lacquered shelf.

P.162 | Dolcevita armchair W 74 D 76, fabric covered with fabric cushion.
Floor-standing People modules in Creta high gloss lacquered.

Dal passato riprende quello stile sobrio e pulito. Panca essenziale dalla struttura metallica, tre morbide sezioni e un cuscino cilindrico. Tanto basta per poter utilizzarla dovunque e comunque, elegantemente.
Panchetta Paesaggio, dove vale lo sguardo.

Its clean, simple style is borrowed from yesteryear. This essential bench features a metal structure, three soft sections and a cylindrical cushion. An elegant chair that will look good anywhere, any way.
Paesaggio bench, where looks count.

Design: Giampaolo Babetto.

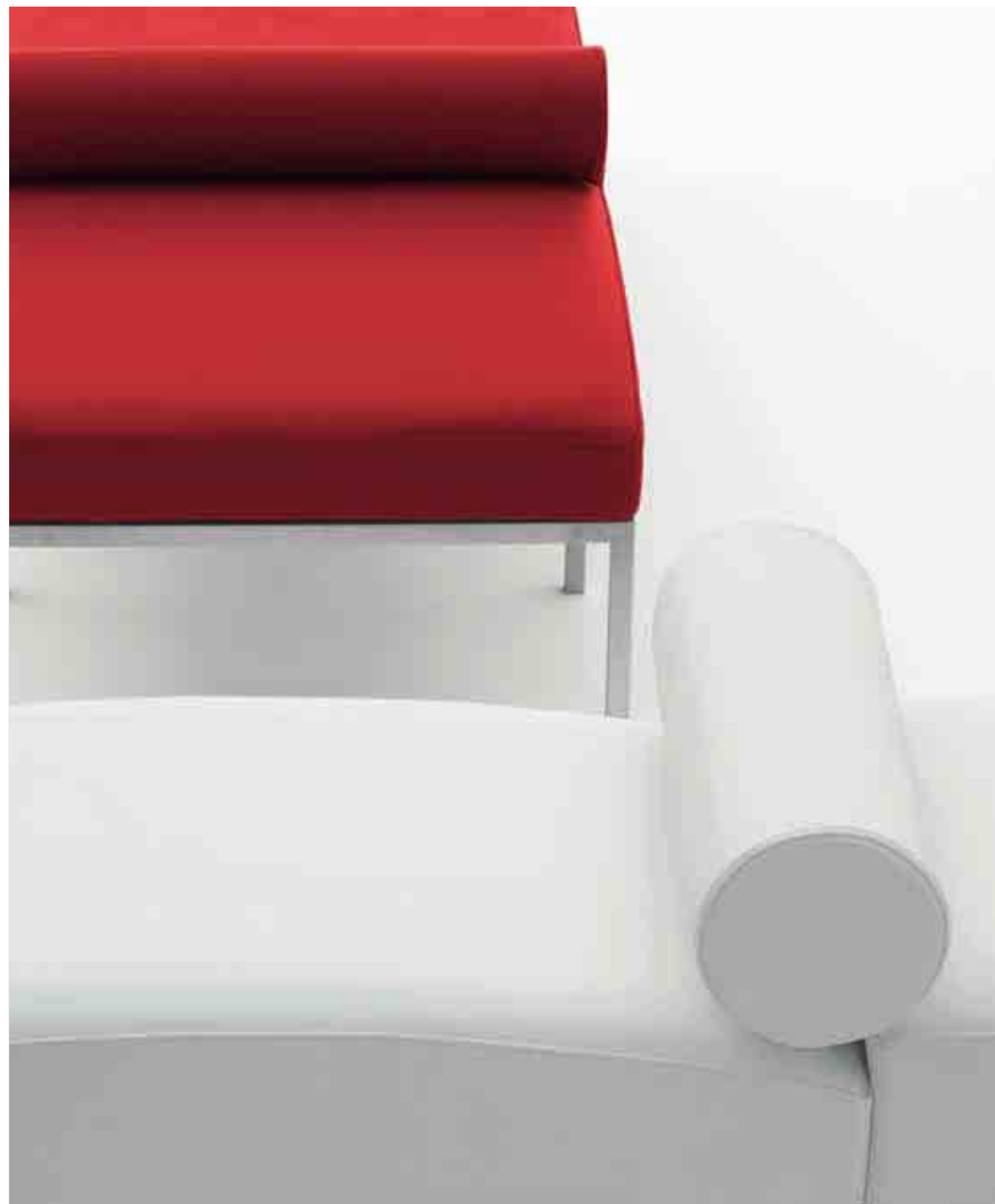





Fg.166-167 | Panchette Paesaggio con rullo L 240 P 45 e L 180 P 60 rivestite in pelle. Moduli Spazio in laccato lucido spazzolato Nero.

Fg.168 | Panchetta Paesaggio con rullo L 240 P 45 rivestita in pelle. Composizioni Spazio in laccato opaco Bianco e Nero.

P.166-167 | Paesaggio ottoman with roll W 240 D 45 and W 180 D 60, leather-covered. Spazio modules in Nero high gloss lacquered.

P.168 | Paesaggio ottoman with roll W 240 D 45, leather-covered. Spazio compositions in Bianco and Nero matt lacquered.



Tavolino Mono, unico per sempre.
Realizzato interamente in metallo verniciato opaco nei 28 colori della collezione.
Disponibile nelle dimensioni L 30 P 30 H 50, L 50 P 50 H 30, L 100 P 100 H 20, L 130 P 70 H 20.

Mono coffee table, ever-unique.
Made entirely in matt painted metal, in the collection's 28 colours.
Available in the dimensions W 30 D 30 H 50, W 50 D 50 H 30, W 100 D 100 H 20, W 130 D 70 H 20.



Tavolino Abaco, le basi dello stile.
Realizzato con struttura in metallo laccato opaco bianco, nero oppure cromato, e piano in laccato opaco nei 28 colori della collezione o in acciaio spazzolato.
Disponibile nelle dimensioni D 60 H 45, D 76 H 30, D 90 H 18.

Abaco coffee table, the foundations of style. With its metal structure in matt white or black lacquer, or in chrome, and top in matt lacquer, in the collection's 28 colours, or in brushed steel.
Available in the dimensions D 60 H 45, D 76 H 30, D 90 H 18.



FRAME EVO

Tavolino Frame Evo, evoluzione da incorniciare.
Realizzato con struttura in metallo verniciato opaco bianco, nero oppure cromato, e piano in vetro opaco e lucido nei 6 colori della collezione o in pietra multicolor e black-line.
Disponibile nelle dimensioni L 91 P 88 H 30 e 18, L 110 P 107 H 30 e 18, L 132 P 71 H 30 e 18.

Frame Evo coffee table, an evolution fit for framing.
With its metal structure in matt white or black lacquer, or in chrome, and top in matt and high-gloss glass, in the collection's 6 colours or in multicolor and black-line stone.
Available in the dimensions W 91 D 88 H 30 and 18, W 110 D 107 H 30 and 18, W 132 D 71 H 30 and 18.

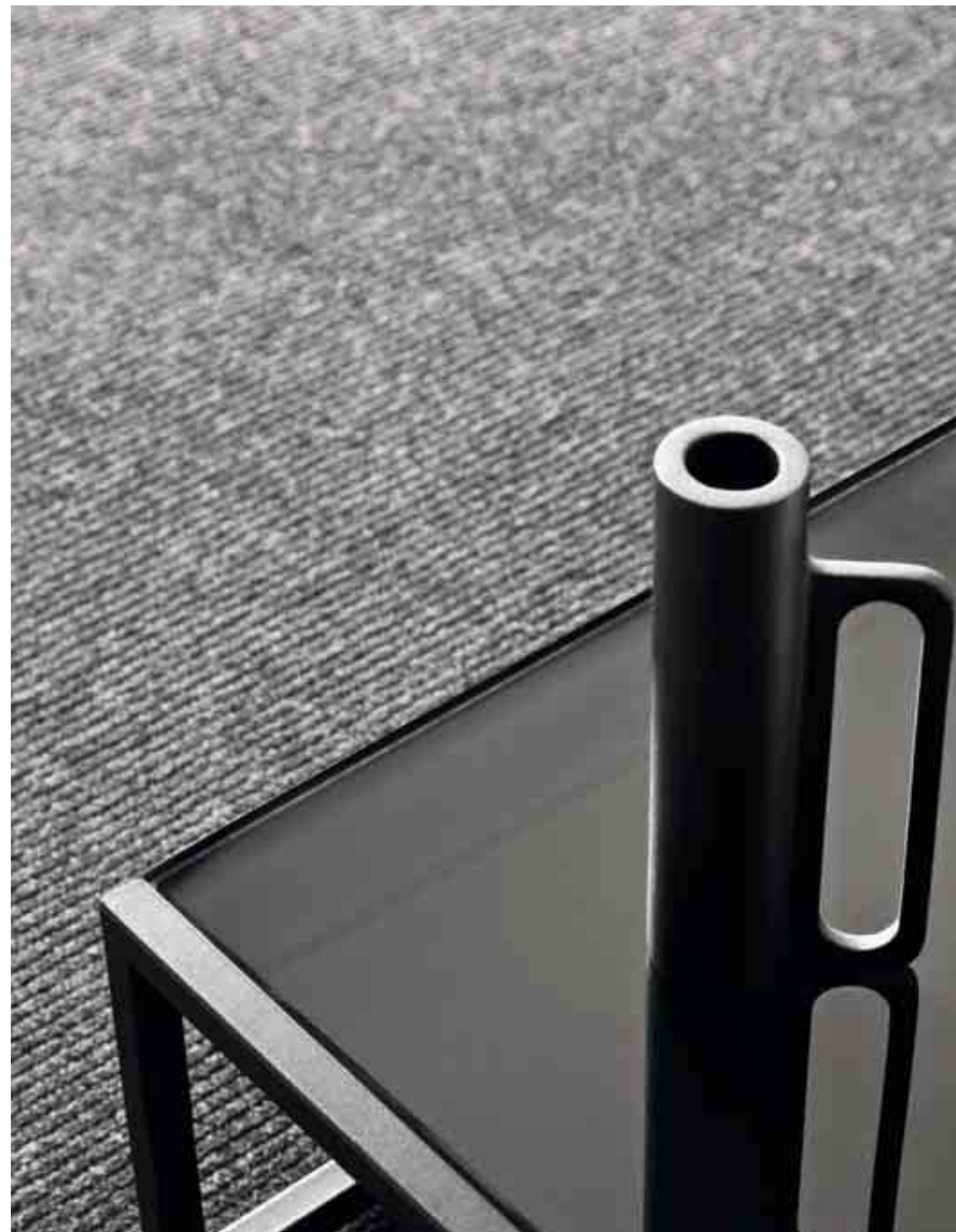
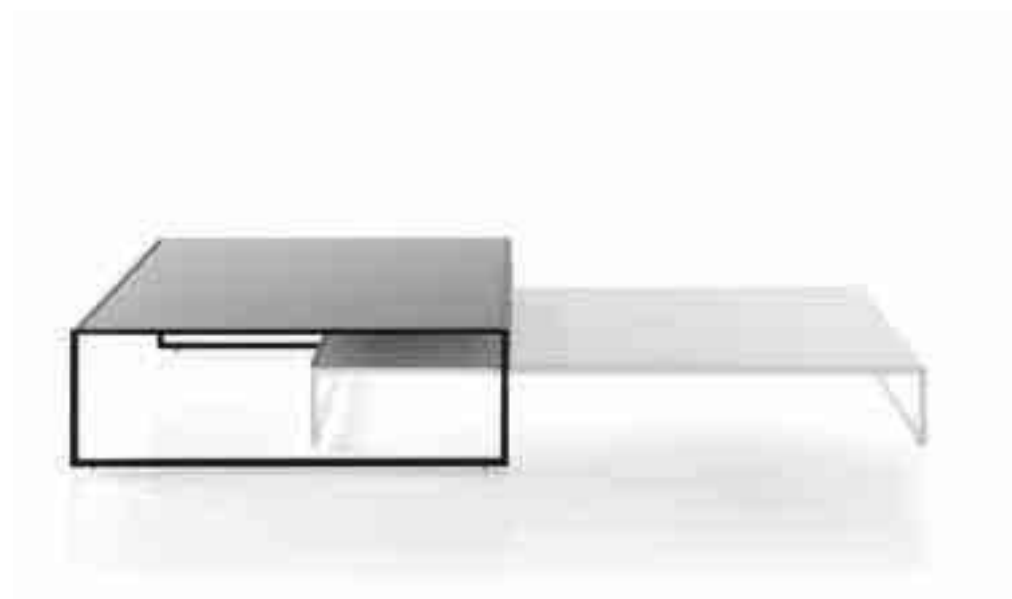

Tavolino Icaro, il limite è il cielo.
Realizzato con struttura in metallo cromato
e con piano in vetro opaco e lucido, nei
6 colori della collezione, o in pietra
multicolor o black-line.
Disponibile nelle dimensioni L 89 P 89
H 23, L 109 P 109 H 23, L 133 P 69 H 23.

Icaro coffee table, the sky's the limit.
With its structure in chrome, and top
in matt and high-gloss glass, in the
collection's 6 colours, or in multicolor or
black-line stone.
Available in the dimensions W 89 D 89 H 23,
W 109 D 109 H 23, W 133 D 69 H 23.



Tavolino Dedalo, dove perdersi è bello.
Realizzato in laccato opaco e lucido nei
colori Bianco, Avorio, Tortora, Nuvola.
Disponibile nella dimensione L 98 P 98 H 25.

Dedalo coffee table, where it's nice to
lose yourself.
Made in matt and high-gloss lacquered in the
colours Bianco, Avorio, Tortora, Nuvola.
Available in the dimensions W 98 D 98 H 25.



Tavolino Delano, sobria eccellenza.
Realizzato interamente in legno laccato
opaco e lucido spazzolato nei 28 colori
della collezione e in essenza.
Disponibile nelle dimensioni L 99 P 99 H 29
e L 131 P 70 H 29.

Delano coffee table, simple excellence.
Made entirely in matt and high-gloss
lacquered wood in the collection's 28
colours and in wood finish.
Available in the dimensions W 99 D 99 H 29
and W 131 D 70 H 29.

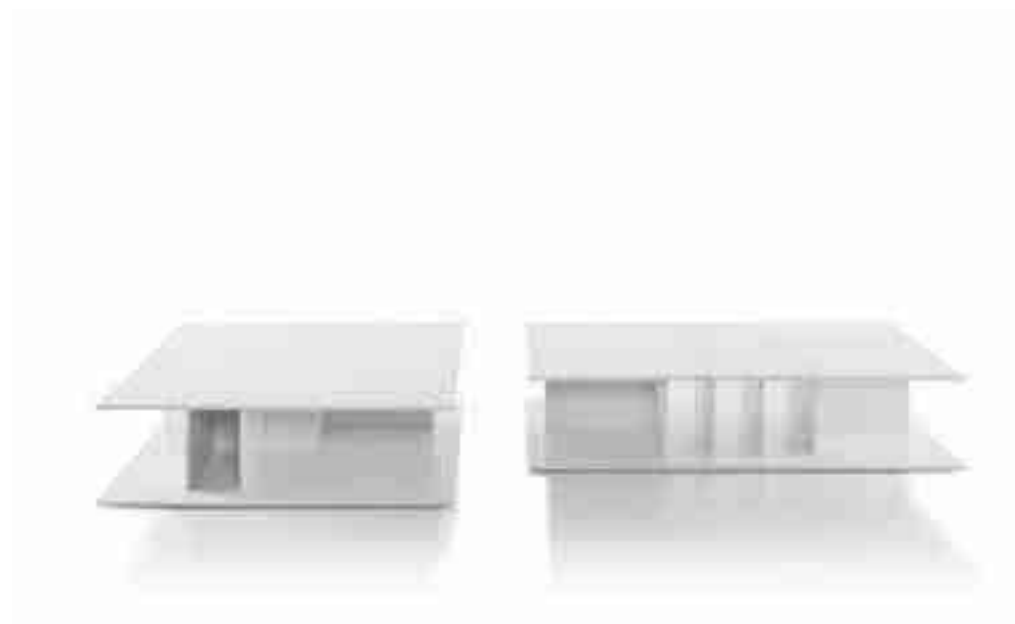

ANTONIETTA

Tavolino Antonietta, il ricamo leggero della grazia. Realizzato interamente in metallo con e senza decoro. Verniciato lucido nei colori Bianco, Rosso e Nero. Disponibile nella dimensione L 38 P 38 H 45.

Antonietta coffee table, the light grace of lacework. Made entirely in high-gloss painted metal with and without pattern in the colours Bianco, Rosso and Nero. Available in the dimensions W 38 D 38 H 45.

Design: Alessandra Pasetti.



Tavolino Joker, battuta vincente.
Realizzato interamente in legno laccato
opaco nei 28 colori della collezione, in
essenza, rivestito in pietra Multicolor o
Black line.
Disponibile nelle dimensioni L 90 P 90 H 12
e L 135 P 65 H 12.

Joker coffee table, a witty winner.
Made entirely in matt lacquered wood in the
collection's 28 colours, in wood finish,
covered in Multicolor or Black line stone.
Available in the dimensions W 90 D 90 H 12
and W 135 D 65 H 12.



SERVOGIRO SERVOQUADRO

Tavolino Servogiro e Servoquadro, forme scelte. Realizzato con struttura in metallo cromato e piano in legno laccato opaco e lucido spazzolato nei 28 colori della collezione, e in essenza.
Servoquadro L 45 P 45 H 53, Servogiro Ø 45 H 53.

Servogiro and Servoquadro coffee tables, selected shapes. With a chrome structure and top in matt lacquered wood in the collection's 28 colours, or in wood finish.
Servoquadro W 45 D 45 H 53, Servogiro Ø 45 H 53.





TESSUTI E PELLI FABRIC AND LEATHER

I divani Pianca sono parte integrante di un progetto coordinato ed evoluto per la casa contemporanea, dallo spazio giorno allo spazio notte. Il loro design si sintonizza immediatamente con gli ambienti, gli arredi ed i gusti di un pubblico moderno e raffinato, che vuole un'estetica di attualità senza mai rinunciare al piacere della comodità e della qualità. Una vasta gamma di tessuti e pelli aggiunge un tocco di esclusività ad ogni composizione. Le limitazioni dei rivestimenti devono essere verificate con il listino.

Pianca sofas are an integrated part of a coordinated and developed project for the contemporary home, from the day to the night spaces. Their design fully integrates with the rooms, the furniture and the preferences of modern and elegant people, which require an updated harmony but without renouncing to the pleasure of quality and comfort. A large collection of fabrics and leathers adds a touch of exclusivity to each composition. Please verify possible limitations of the coverings in the price list.

CUSTOM BY RUBELLI



BIANCO

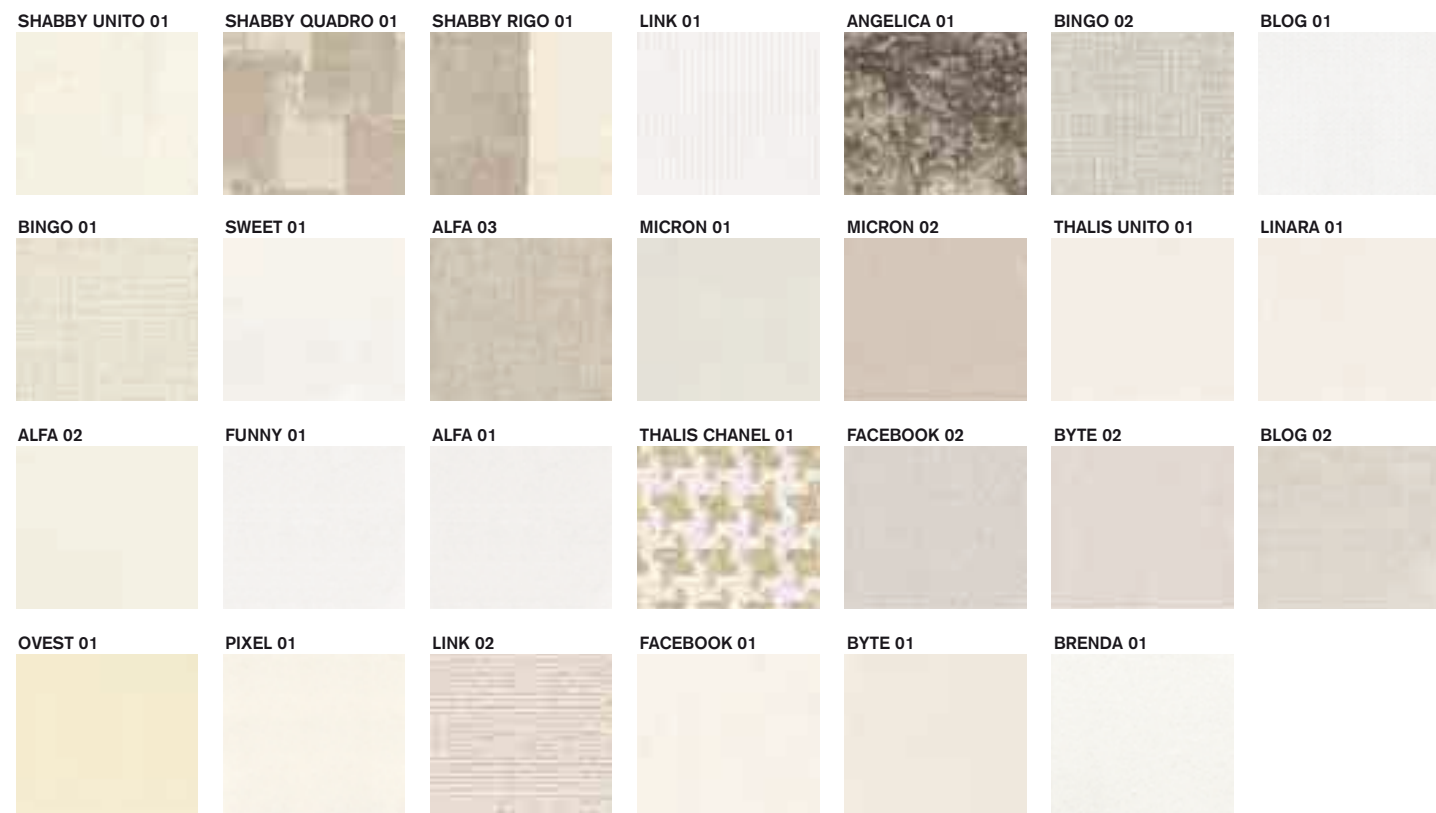

BEIGE



CAT. A | alfa - bingo - blog - denim - funny - link - nord - ovest
 linara - micron - pixel - sweet - thalis unito
 CAT. B | angelica - byte - facebook - fiordaliso -
 CAT. C | brenda - dakar - danubio - nevado - niger - shabby - stone - thalis chanel

CAT. A | alfa - bingo - blog - denim - funny - link - nord - ovest
 linara - micron - pixel - sweet - thalis unito
 CAT. B | angelica - byte - facebook - fiordaliso -
 CAT. C | brenda - dakar - danubio - nevado - niger - shabby - stone - thalis chanel

ROSSO E VIOLA



MARRONE



CAT. A | alfa - bingo - blog - denim - funny - link - nord - ovest
 linara - micron - pixel - sweet - thalis unito
 CAT. B | angelica - byte - facebook - fiordaliso -
 CAT. C | brenda - dakar - danubio - nevado - niger - shabby - stone
 - thalis chanel

CAT. A | alfa - bingo - blog - denim - funny - link - nord - ovest
 linara - micron - pixel - sweet - thalis unito
 CAT. B | angelica - byte - facebook - fiordaliso -
 CAT. C | brenda - dakar - danubio - nevado - niger - shabby - stone
 - thalis chanel

BLU E VERDE

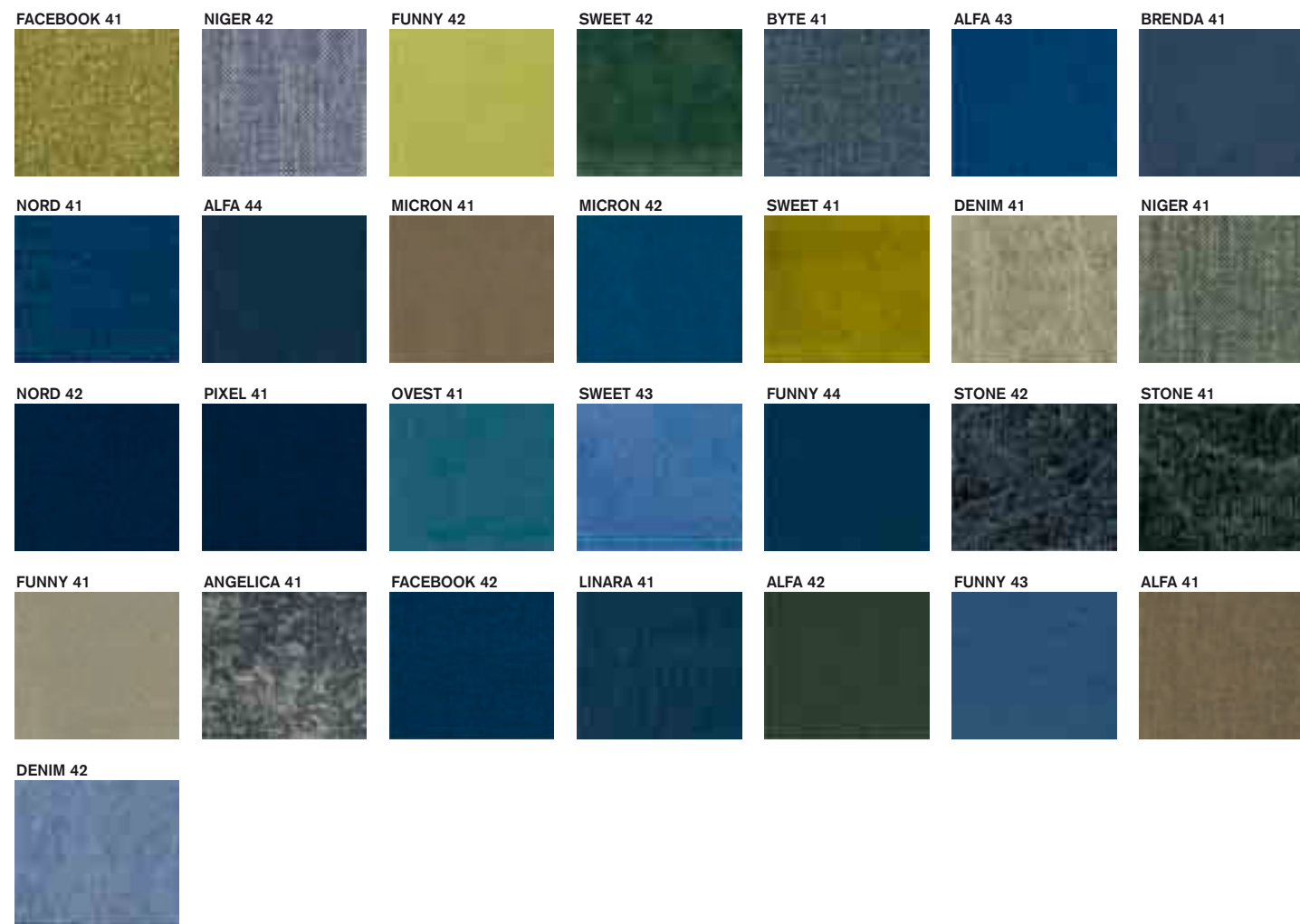

GRIGIO E NERO



CAT. A | alfa - bingo - blog - denim - funny - link - nord - ovest
 linara - micron - pixel - sweet - thalis unito
CAT. C | brenda - dakar - danubio - nevado - niger - shabby - stone - thalis chanel

CAT. A | alfa - bingo - blog - denim - funny - link - nord - ovest
 linara - micron - pixel - sweet - thalis unito
CAT. C | brenda - dakar - danubio - nevado - niger - shabby - stone - thalis chanel

**PELLE E CUOIO
LEATHER AND HIDE**



**PELLE SINTETICA
ECO-LEATHER**



**CERNIERE LIMBO
LIMBO ZIPPERS**



BIANCO

abbinato ai tessuti: bianco, rosso e viola
matched with fabric colours: bianco, rosso e viola



BEIGE

abbinato ai tessuti: beige, marrone
matched with fabric colours: beige, marrone



NERO

abbinato alle pelli, alle pelli sintetiche e ai tessuti: blu e verde, grigio e nero, custom by Rubelli
matched with leather and ecoleather and with fabric colours: blu e verde, grigio e nero, custom by Rubelli

**BORDINO DIVANI IN CONTRASTO
SOFA'S EDGE**

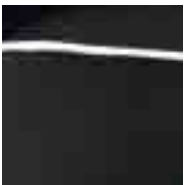

BIANCO

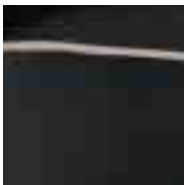

BEIGE



GRIGIO



ROSSO SCURO



NERO

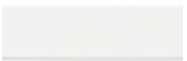

MADIE TAVOLI SEDIE



PIANCA

INDICE INDEX

Madie / Sideboards	
Quadra	8
Contemporanea	14
Spazio lineare	20
Vision	30
Spazio volumi	36
Spazio giorno	42
People	48
Tavoli / Tables	
Soffio	56
Minisoffio	62
Delta	68
Cartagena	74
Next Evo	80
Magno	86
Sedie / Chairs	
Gamma	94
Karma	98
Emi	102
Nuvola	106
Kelly12	110
Asia	114
Finiture / Finishes	120
Info tecniche / Technical infos	126

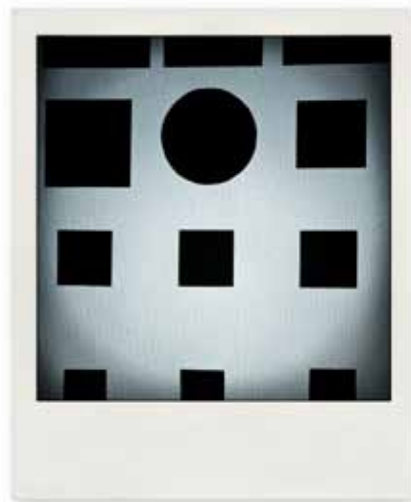



QUADRA

Guardala. È come quella risposta immediata e corretta, data quasi per caso a una domanda importante e decisiva. Al momento giusto, eccola: hai trovato la Quadra. L'espressione diventa sicura e netta, piena di angoli retti, in un'estetica di stile che non permette indecisioni, o dubbi. Madia Quadra. Idee chiare.

Look at it. It's like that immediate and correct answer, you give almost for chance to an important and decisive question. At the right moment, here it is: you have found the Quadra. The expression becomes certain and sharp, with many right angles, its aesthetic of style doesn't allow doubts or indecision. Quadra sideboard. Clear Ideas.







Pg.9 | Madia Quadra pensile con cassetti e ribalta in laccato opaco Prato: L 240 H 60 P 45.

Pg.10-11 | Madie Quadra a terra con cassetti e ante ribalta battenti in laccato opaco Creta: L 120 H 121 P 45.
Tavolo Magno con struttura in laccato opaco Bianco e piano in vetro lucido verniciato Bianco: L 220 H 75 P 100.
Sedie Emi imbottite e rivestite in pelle Pantea: L 49 H 85 P 61.

Pg.12 | Dettaglio della prensilità caratterizzante ricavata direttamente nel pannello.

Pg.13 | Suggerimenti compositivi: sopra L 120 H 181 P 45, sotto L 240 H 61 P 45.

P.9 | Quadra wall-hanging sideboard with Prato matt lacquered flap door and drawers: W 240 H 60 D 45.

P.10-11 | Quadra floor-standing sideboards with drawers and wing doors in Creta matt lacquered: W 120 H 121 D 45.
Magno table with structure in Bianco matt lacquered and top in Bianco high gloss glass: W 220 H 75 D 100.
Upholstered Emi chairs covered in Pantea leather: W 49 H 85 D 61.

P.12 | Detail of characteristic grip on front panel, formed directly within the panel itself.

P.13 | Composition ideas: above W 120 H 181 D 45, below W 240 H 61 D 45.

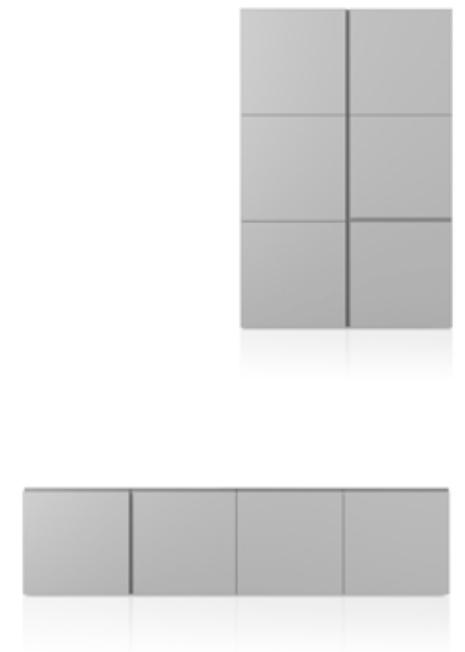

CONTEMPORANEA

Comodi spazi interni e ampie superfici esaltano le curve della maniglia. Una coppia di semicerchi offre movimento, mentre il metallo satinato o verniciato dona materia. Ariosità ed equilibrio emergono dal top incassato armonizzato agli oggetti esterni in un unico volume di forme. Madia Contemporanea. In sintonia con il nostro tempo.

Comfortable internal spaces and wide surfaces enhance the curves of the handle. A sense of movement is given by a couple of semicircles, the painted or a tinized metal emphasizes the beauty of the materials. The top suggests balance and air to the external objects in a unique volume of shapes. Contemporanea Sideboard in tune with our times.







Pg.15 | Madie Contemporanea a terra con ante battenti in laccato lucido spazzolato Artico e maniglia in alluminio spazzolato: L 120 H 141 P 45.

P.15 | Contemporanea floor-standing sideboards with wing doors in Artico high gloss lacquered and brushed aluminium handle: W 120 H 141 D 45.

Pg.16-17 | Madia Contemporanea pensile con ante complanari in laccato opaco Bianco senza maniglia: L 240 H 60 P 45.

P.16-17 | Contemporanea wall-hanging sideboard with coplanar doors in Bianco matt lacquered, without handles: W 240 H 60 D 45.

Tavolo Delta con gambe in laccato opaco Bianco e piano in vetro trasparente: L 220 H 75 P 100.

Delta table with Bianco matt lacquered legs and transparent glass top: W 220 H 75 D 100.

Sedia Karma con struttura e seduta in legno laccato opaco Nero: L 48 H 81 P 54.

Karma chair with structure and seat in Nero matt lacquered wood: W 48 H 81 D 54.

Pg.18 | Dettaglio dell'interno nella versione battente con schiena in vetro acidato retroilluminato a led e maniglia in alluminio spazzolato.

P.18 | Detail of interior in wing-door version with back in backlit etched glass and brushed aluminium handle.

SPAZIO LINEARE

Lo spazio non si deforma, ma si sovrappone componibile e personalizzabile. La precisione dei dettagli e il ritmo dei volumi laccati, in vetro, o pietra formano strutture definite. Se la strada più breve per raggiungere il traguardo è una linea retta, avanti tutta.
Madia Spazio Lineare. Segui le coordinate giuste.

There is no distortion of the space, but you can compose it and personalize it. The accuracy in the details and the rhythm of the volumes, made in glass, varnish or stone, realize definite structures. If the fastest way to reach the goal is a straight line, full speed ahead.
Spazio Lineare Sideboard. Follow the right path.





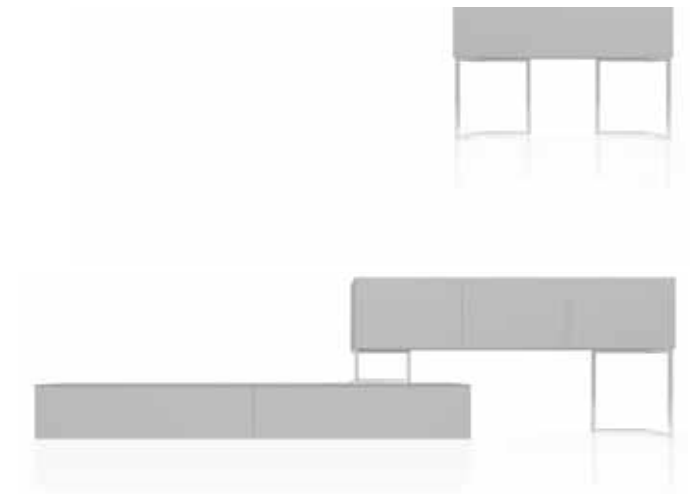

Pg.21 M161 | Moduli Spazio a terra con ante battenti e pedana in laccato lucido spazzolato Visone in appoggio su basamento laccato opaco in tinta: L 300 H 76 P 55.

P.21 M161 | Spazio floor-standing modules with wing doors and base in Visone high gloss lacquered, standing on a matching matt lacquered platform: W 300 H 76 D 55.

Pg.22-23 M162 | Moduli Spazio con ante battenti, fianchi e top in pietra Black Line, in appoggio su basamento cromato: L 241 H 71 P 55.
Tavolo Soffio con struttura in laccato opaco Creta e piano in vetro opaco verniciato Creta: L 140 H 75 P 140.
Sedie Gamma con struttura a traliccio in metallo cromato e seduta imbottita e rivestita in tessuto sfoderabile: L 52 H 79 P 52.

P.22-23 M162 | Spazio with wing doors, sides and top Black Line stone, standing on a chrome platform: W 241 H 71 D 55.
Soffio table with structure in Creta matt lacquered and top in Creta matt glass: W 140 H 75 D 140.
Gamma chairs with chrome pylon structure and upholstered seat with removable cover: W 52 H 79 D 52.

Pg.24 | Dettaglio del basamento laccato opaco Nero.

P.24 | Detail of Nero matt lacquered support.

Pg.25 | Suggestioni compositivi: sopra M163, L 120 H 91 P 45; sotto M164, L 360 H 93 P 55.

P.25 163-164 | Composition ideas: above M163, W 120 H 91 D 45; below M164, W 360 H 93 D 55.





Fg.26-27 M165-M166 | Moduli Spazio a terra con ante battenti e top in laccato opaco Bianco: sx L 150 H 153 P 45, dx L 100 H 153 P 45. Tavolo Cartagena con struttura e piano in essenza Rovere Scuro: L 240 H 75 P 100. Sedie Asia con struttura in legno Rovere Scuro e seduta imbottita e rivestita in pelle sintetica: L 43 H 86 P 52.

Fg.28 M167 | Moduli Spazio pensili con ante battenti e top in laccato opaco e lucido spazzolato Bosco: L 240 H 62 P 45.

Fg.29 | Suggestioni compositivi: sopra M168, L 100 H 141 P 45; sotto M169, L 270 H 63 P 45.

P.26-27 M165-M166 | Spazio floor-standing modules with wing doors and top in Bianco matt lacquered: left W 150 H 153 D 45, right W 100 H 153 D 45. Cartagena table with structure and top in Rovere Scuro: W 240 H 75 D 100. Asia chairs with structure in Rovere Scuro and upholstered seat covered with eco-leather: W 43 H 86 D 52.

P.28 M167 | Spazio wall-hanging modules with wing doors and top in Bosco matt and high gloss lacquered: W 240 H 62 D 45.

P.29 | Composition ideas: above M168, W 100 H 141 D 35; below M169, W 270 H 63 D 45.

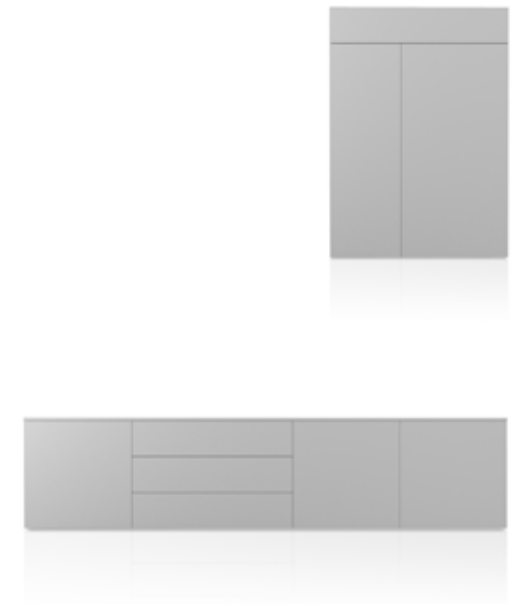

Le aperture scorrevoli dilatano lo spazio senza occupare profondità e ambiente. Con un tocco leggero si liberano alla vista il top e il pannello frontale, per scoprirne agile il contenuto. Accessibilità immediata e totale per un'interpretazione pratica e flessibile del living.
Madia Vision. Vedere oltre l'idea.

The sliding openings expand in the space, without bothering the profundity of the environment. With a gentle touch you can free the top and the frontal panel discovering easily the contents of the sideboard. Immediate and total access for a practical and flexible interpretation of the living.
Vision Sideboard. Seeing beyond the idea.







Pg.31 | Moduli Vision pensili con ante scorrevoli in laccato opaco Mela: L 240 H 40 P 45.
Sedia Gamma con struttura a quattro razze in Rovere Naturale e seduta in laccato opaco Bianco: L 51 H 78 P 51.

Pg.32-33 | Modulo Vision a terra con struttura in laccato opaco Avorio ed ante scorrevole in vetro lucido verniciato Avorio: L 240 H 62 P 45.
Tavolo Next Evo con struttura e piano in laccato opaco antigraffio Lavagna: L 220 H 75 P 100.
Sedia Nuvola con struttura e seduta in laccato lucido Nero: L 47 H 77 P 58.

Pg.34 | Dettaglio del modulo cassetto interno in contrasto di colore rispetto alla struttura.

P.31 | Vision wall-hanging modules with sliding doors in Mela matt lacquered: W 240 H 40 D 45.
Gamma chair with four rocket legs in Rovere Naturale and seat in Bianco matt lacquered: W 51 H 78 D 51.

P.32-33 | Vision floor-standing modules with structure in Avorio matt lacquered and sliding door in Avorio high gloss glass: W 240 H 62 D 45.
Next Evo table with structure and top in scratchproof Lavagna matt lacquered: W 220 H 75 D 100.
Nuvola chair with structure and seat in Nero high gloss lacquered: W 47 H 77 D 58.

P.34 | Detail of internal drawer modules in contrasting colour with structure.

SPAZIO VOLUMI

Ecco come inserirsi con disinvoltura in ogni situazione di casa, sfruttando un concetto di modularità pressoché infinita. Tra cassetti, cassettoni, contenitori ad anta battente o ribalta, elementi d'arredo pensati per mostrare, organizzare, riporre e nascondere.
Madia Spazio Volumi. Profondità di spirito.

It fits with confidence in every home situation, exploiting an almost endless concept of modularity. Drawers and containers with hinged doors, furniture elements made to show, organize, hide and shelve. Spazio Volumi Sideboard. Profundity of spirit.





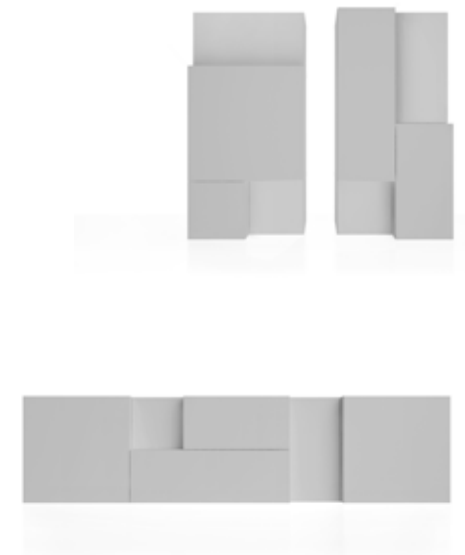

Pg.37 M171 | Moduli Spazio pensili con ante battenti in laccato opaco Oltremare: L 300 H 60 P 45.

P.37 M171 | Spazio wall-hanging modules with wing doors in Oltremare matt lacquered: W 300 H 60 D 45.

Pg.38-39 M172 | Moduli Spazio a terra con ante battenti in poro aperto Corda: L 250 H 121 P 45.
Tavolo Delta con gambe in acciaio e piano in vetro trasparente: L 220 H 75 P 100.
Sedie Emi imbottite e rivestite in pelle Pantea: L 49 H 85 P 61.

P.38-39 M172 | Spazio floor-standing modules with wing doors in Corda poro aperto finish: W 250 H 121 D 45.
Delta table with steel legs and top in transparent glass: W 220 H 75 D 100.
Upholstered Emi chairs covered in Pantea leather: W 49 H 85 D 61.

Pg.40 | Dettaglio del cambio di profondità nella finitura poro aperto.

P.40 | Detail of change in depth of poro aperto finish.

Pg.41 | Suggerimenti compositivi: sopra a sx M173, L 60 H 121 P 45; sopra a dx M174, L 60 H 121 P 45; sotto M175, L 240 H 61 P 45.

P.41 | Composition ideas: above left M173, W 60 H 121 D 45; above right M174, L 60 H 121 P 45; below M175, W 240 H 61 D 45.

SPAZIO GIORNO

Spazi in continua evoluzione liberano la fantasia creativa. Elementi contenitori decisi e raffinati si combinano perfettamente a moduli pensili, caratterizzati da profili con spigoli diamantati, sfuggenti e leggeri alla vista. Indimenticabile. Madia Spazio Giorno. Magia quotidiana.

Spaces in evolution let the creative imagination free. Sophisticated and strong containing elements combine perfectly with suspended units, characterized by profiles with diamond cut edges, light and evasive to the sight. Unforgettable. Spazio Giorno Sideboard. Daily magic.







Pg.43 M181 | Moduli Spazio a terra e pensili con cassetti, ante ribalta o battenti e moduli a giorno in laccato opaco Bianco: L 120 H 161 P 35.
Tavolino Abaco con struttura e piano in laccato opaco Bianco: Ø 90 H 18.

Pg.44-45 M182 | Moduli Spazio a terra con ante battenti, fianchi e top in vetro lucido verniciato Lavagna, e moduli a giorno in laccato opaco Sole: L 241 H 62 P 45.
Tavolo Soffio con struttura e piano in laccato opaco Sole: L 140 H 75 P 140.
Sedia Kelly12 con schienale basso, imbottita e rivestita in cuoietto Nero: L 45 H 87 P 56.

Pg.46 | Dettaglio della particolare lavorazione a 45° dei moduli a giorno.

Pg.47 | Suggestioni compositivi: sopra M183, L 150 H 143 P 45; sotto M184, L 270 H 63 P 45.

P.43 M181 | Spazio floor-standing and wall-hanging modules with drawers, tilting or wing doors and open modules in Bianco matt lacquered: W 120 H 161 D 35.
Abaco coffee table with structure and top in Bianco matt lacquered: Ø 90 H 18.

P.44-45 M182 | Spazio floor-standing modules with wing doors, sides and top in Lavagna high gloss glass, and open modules in Sole matt lacquered: W 241 H 62 D 45.
Soffio table with structure and top in Sole matt lacquered: W 140 H 75 D 140.
Kelly12 chair with low seat back, upholstered and covered in Nero hide: W 45 H 87 D 56.

P.46 | Detail of the distinctive 45° feature of the open modules.

P.47 | Composition ideas: above M183, W 150 H 143 D 45; below M184, W 270 H 63 D 45.

Le sue molteplici possibilità espressive e compositive cambiano e si espandono nello spazio e nel tempo, per soddisfare le esigenze qualitative delle persone nelle case di domani, grazie alla superiore qualità dei materiali e all'estrema cura con la quale sono assemblati. Madia People Collection. Vivere assieme fa bene.

Its multiple expressive and composite possibilities, change and expand in space and time, to satisfy the demand of quality of people's future houses, thanks to the superior quality of the materials and to the extreme care we put in assembling the pieces. People Collection Sideboard. It's good living together.





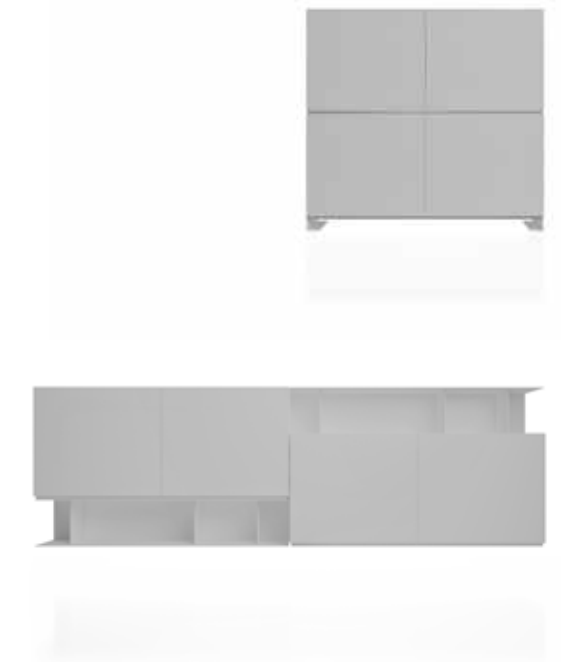

Fg.49 P950 | Moduli People pensili con ante ribalta in essenza Rovere Grigio e moduli a giorno in acciaio spazzolato: L 327 H 61 P 42.

P.49 P950 | People wall-hanging modules with tilting doors in Rovere Grigio, and open modules in brushed steel: W 327 H 61 D 42.

Fg.50-51 | Madia People a terra con ante complanari in laccato opaco Artico: L 261 H 73 P 52.

P.50-51 | People floor-standing sideboard with coplanar doors in Artico matt lacquered: W 261 H 73 D 52.

Tavolo Soffio con struttura in laccato opaco Bianco e piano in vetro lucido verniciato Bianco: L 240 H 75 P 120.

Soffio table with structure in Bianco matt lacquered and top in Bianco high gloss glass: W 240 H 75 D 120.

Sedie Gamma con struttura a quattro gambe in metallo e seduta in laccato lucido Bianco: L 51 H 78 P 51.

Gamma chairs with four metal legs and Bianco high gloss lacquered seat: W 51 H 78 D 51.

Fg.52 | Dettaglio della prensilità dei frontali ricavata direttamente nella struttura.

P.52 | Detail of the grip on the front panels, formed directly within the structure.

Fg.53 | Suggestioni compositivi: sopra P951, L 131 H 123 P 42; sotto P952, L 261 H 87 P 42.

P.53 | Composition ideas: above P951, W 131 H 123 D 42; below P952, W 261 H 87 D 42.



Per avere un tavolo originale e completamente personalizzabile basta un soffio. Spigoli diamantati e ventotto colori possibili da abbinare a dimensioni diverse. Ridisegna il soggiorno con un tratto leggero. Essenziale nelle linee e nei volumi, vive d'aria.
Tavolo Soffio. Il giusto peso dell'eleganza.

To get an original and completely personalized table you just need a blow. Diamond cut edges and twenty-eight possible colours that match with different dimensions. Design the living room with a smooth sign. Essential in the lines and volumes, it lives of air.
Soffio Table. The right weight of elegance.





Pg.57 | Tavolo Soffio con struttura in laccato opaco Bianco e piano in vetro opaco verniciato Bianco: L 240 H 75 P 100.
Sedie Gamma con struttura a traliccio in metallo cromato e seduta imbottita e rivestita in tessuto sfoderabile: L 52 H 79 P 52.

P.57 | Soffio table with structure in Bianco matt lacquered and top in Bianco matt glass: W 240 H 75 D 100.
Gamma chairs with chrome pylon structure and upholstered seat with removable cover: W 52 H 79 D 52.

Pg.58-59 | Tavolo Soffio con struttura e piano in laccato opaco antigraffio Lavagna: L 240 H 75 P 100.
Sedie Asia con struttura in legno Rovere Grigio e seduta imbottita e rivestita in pelle sintetica: L 43 H 86 P 52.

P.58-59 | Soffio table with structure and top in Lavagna matt scratchproof lacquered: W 240 H 75 D 100.
Asia chairs with structure in Rovere Grigio and upholstered seat covered with eco-leather: W 43 H 86 D 52.

Pg.60-61 | Vista frontale e laterale del tavolo Soffio nella posizione chiusa (A), allungata di L 60 (B) o con seconda allunga addizionale di L 60 (C).

P.60-61 | Front and side view of Soffio table in its closed position (A), extended by 60 cm (B) or with additional second 60 cm extension (C).

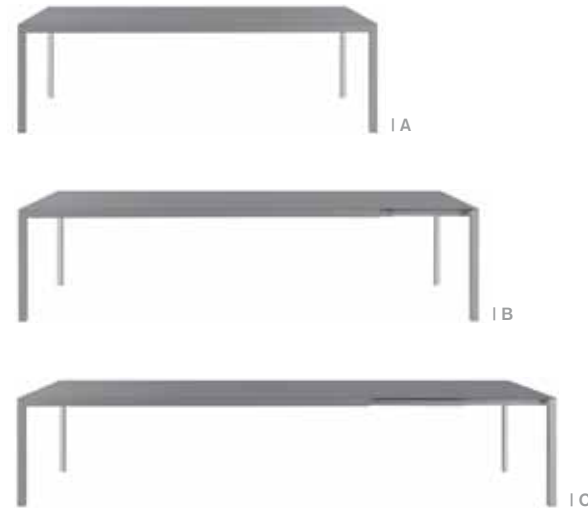

MINISOFFIO

Sboccia come un fiore, cresce e si espande. Ideale sia per gli ambienti molto piccoli e raccolti che per quelli più ampi e ariosi, soddisfa ogni spazio grazie alle sue cinque allunghe a scomparsa. Versatile e dinamica, si presta a svolgere innumerevoli funzioni. Minisoffio. Vitale come un respiro.

It blossoms like a flower, expanding and growing. Ideal for small and cozy environments and for airy and wide ambients, satisfying every space thanks to its five retractable extensions. Dynamic and versatile, it's able to perform different functions. Minisoffio. Vital as a breath.





Pg.63 | Consolle Minisoffio chiusa con struttura e piano in laccato opaco antigraffio Artico: L 140 H 75 P 45.

Pg.64-65 | Consolle Minisoffio aperta con struttura e piano in laccato opaco antigraffio Artico: L 140 H 75 P 270. Sedia Emi imbottita e rivestita in pelle Pantea: L 49 H 85 P 61.

Pg.66-67 | Vista frontale e laterale della consolle Minisoffio nella posizione chiusa (A), allungata di P 45*5 (B).

P.63 | Minisoffio console table, closed, with structure and top in Artico matt scratchproof lacquered: W 140 H 75 D 45.

P.64 | Minisoffio console table, open, with structure and top in Artico matt scratchproof lacquered: W 140 H 75 D 270. Emi chair, upholstered and covered in Pantea leather: W 49 H 85 D 61.

P.66-67 | Front and side view of Minisoffio console table in its closed position (A), extended by 45*5 cm (B).

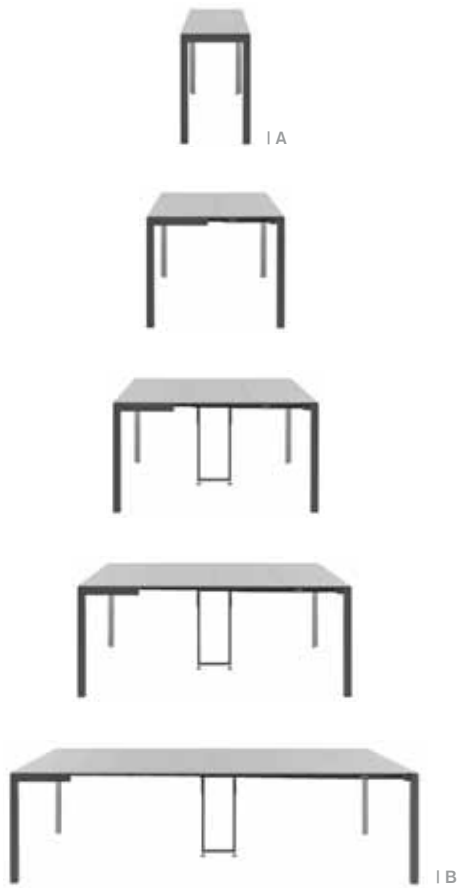

Appoggiata a una trave centrale allungabile, la superficie vitrea e trasparente aiuta a scorgere meglio la bellezza, che si nutre di equilibrio e brilla su gambe a cavalletto, fresche d'acciaio, o calde di legno. Il design permette una stabilità reale e conia uno stile innovativo. Leggero, oltre lo specchio.

Tavolo Delta. Estetica e tecnologia.

Leaning on a central extended timber, its beauty and balance is emphasized by the glassy and transparent surface. It shines on trestle legs, fresh of steel or warm in wood. The design permits a real stability and realizes a innovative style. Light, beyond the mirror.

Delta Table. Aesthetics and technology.





NE PAS DECLENCHER
MANOEUVRE



1100

Pg.69 | Tavolo Delta con trave allungabile e gambe in acciaio spazzolato, piano in vetro trasparente: L 220 H 75 P 100.

Sedie Gamma con struttura a quattro gambe in metallo e seduta in laccato lucido Bianco L 51 H 78 P 51.

Pg.70-71 | Tavolo Delta con trave allungabile in acciaio spazzolato, gambe in Rovere Naturale e piano in vetro trasparente: L 220 H 75 P 100.

Sedie Gamma con struttura a quattro razze in Rovere Naturale e seduta in laccato opaco Bianco: L 51 H 78 P 51.

Pg.72-73 | vista frontale e laterale del tavolo Delta nella posizione chiusa (A), allungata di L 45 (B) o con doppia allunga di L 45 + 45 (C).

P.69 | Delta table with extending beam and legs in brushed steel, top in transparent glass: W 220 H 75 D 100.

Gamma chairs with four metal legs and Bianco high gloss lacquered seat: W 51 H 78 D 51.

P.70-71 | Delta table with extending beam in brushed steel, legs in Rovere Naturale and top in transparent glass: W 220 H 75 D 100.

Gamma chairs with four rocket legs in Rovere Naturale and Bianco matt lacquered seat: W 51 H 78 D 51.

P.72-73 | Front and side view of Delta table in its closed position (A), extended by 45 cm (B), or with double 45 + 45 cm extension (C).



CARTAGENA

Gambe ampie e salde di chi viaggia e vuole andare lontano. Doghe solide e spesse per accogliere a dovere. Legno caldo ed essenza a riscaldare, incisioni belle da sentire, con le mani, sul piano naturale. Se chiudi gli occhi, il mare.
Tavolo Cartagena. La passione che ritorna.

A table to travel far away needs strong and big legs. Firm and thick staves able to welcome when necessary. Warm wood in essence, it is a pleasure to feel with the palm of a hand the woodcut on the natural surface. At eyes closed, the sea.
Cartagena Table. The passion returns.





Pg.76-77 | Tavolo Cartagena con struttura e piano in essenza Canaletto: L 240 H 75 P 100.
Sedie Karma con struttura e seduta in legno laccato opaco Bianco e Nero: L 48 H 54 P 81.

P.76-77 | Cartagena table with structure and top in Canaletto: W 240 H 75 D 100.
Karma chair with structure and seat in Bianco matt and Nero lacquered wood: W 48 H 54 D 81.

Pg.78-79 | Vista frontale e laterale del tavolo Cartagena, nella posizione chiusa (A) o allungata di L 50 (per L 149 e 182) o L 60 (per L 200 e 240) (B).

P.78-79 | Front and side view of Cartagena table in its closed position (A) or extended by 50 cm (for a W of 149 and 182) or 60 cm (for a W of 200 and 240) (B).

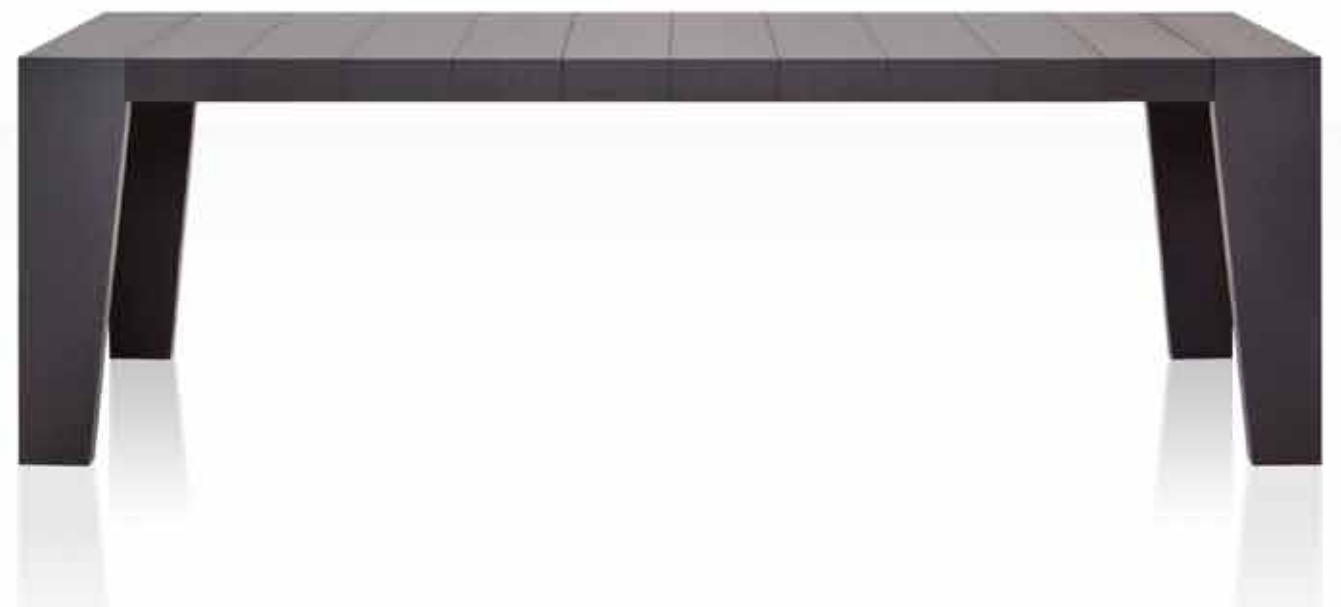

Da oggi c'è un tavolo unico e speciale.
Gli incastri perfetti e le finiture
superiori rinforzano ulteriormente la sua
linea inedita e già sicura. Laccato o nelle
differenti essenze del legno, si distingue
per l'eleganza e la sobrietà degli
elementi, ingredienti fondamentali di un
presente migliore. Immagina cosa succederà
domani.
Tavolo Next Evo. Un passo avanti.

Today there is a unique and special table.
The perfect frames and the superior details
enforce its original and certain lines.
Varnished or in the different essences of
wood, unique for the elegance and sobriety
of the elements, fundamental ingredients of
a better present. Imagine what could happen
tomorrow.
Next Evo Table. A step forward.

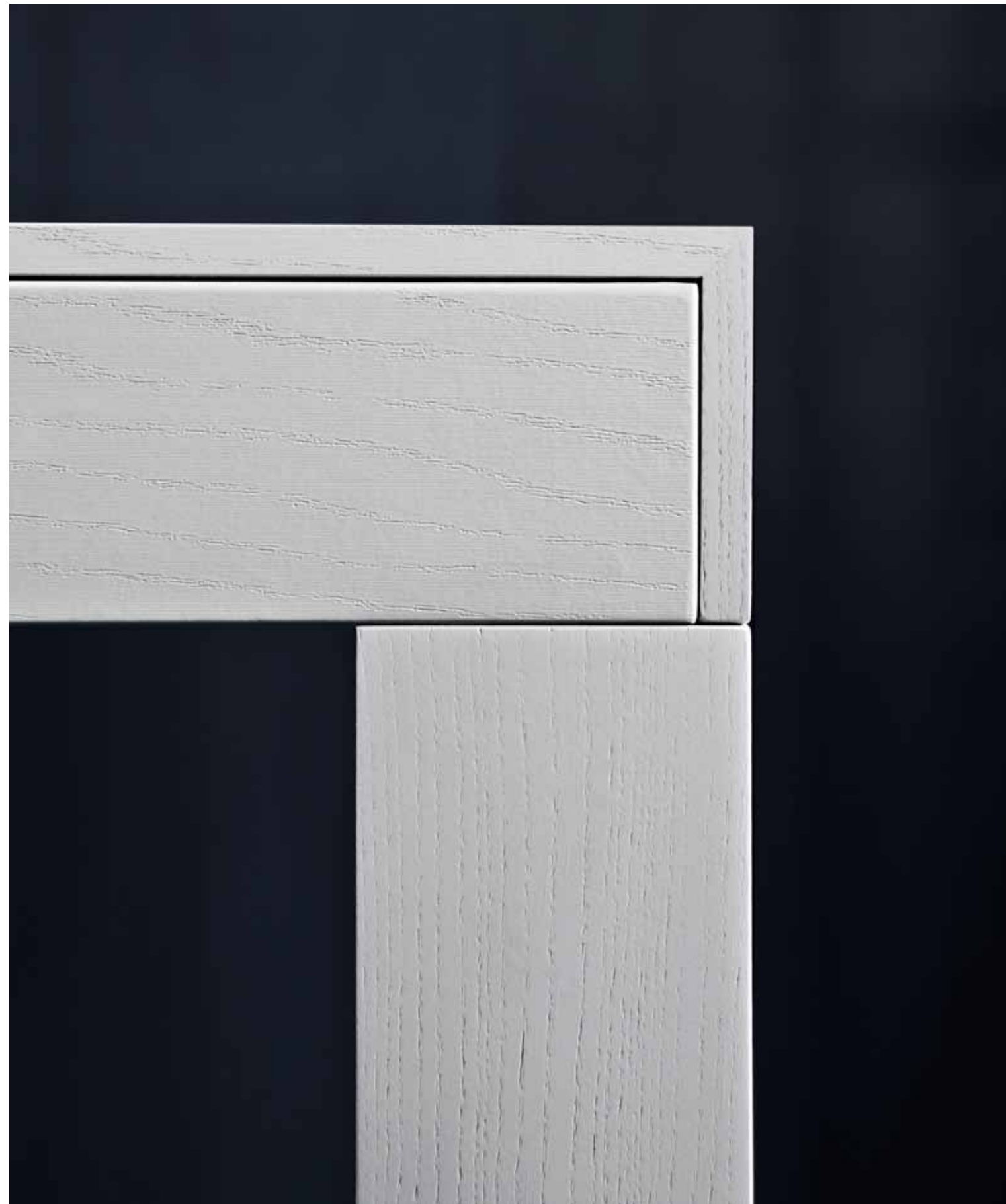



Pg.82-83 | Tavolo Next Evo con struttura e piano in poro aperto laccato opaco Corda: L 220 H 75 P 100. Sedia Nuvola con struttura e seduta in laccato lucido Nero: L 47 H 77 P 58.

Pg.84-85 | Vista frontale e laterale del tavolo Next Evo nella posizione chiusa(A), allungata di L 60(B) o con seconda allunga addizionale di L 60(C).

P.82-83 | Next Evo table with structure and top in Corda matt lacquered poro aperto finish: W 220 H 75 D 100. Nuvola chair with structure and seat in Nero high gloss lacquered: W 47 H 77 D 58.

P.84-85 | Front and side view of Next Evo table in its closed position (A), extended by 60 cm (B) or with additional second 60 cm extension (C).

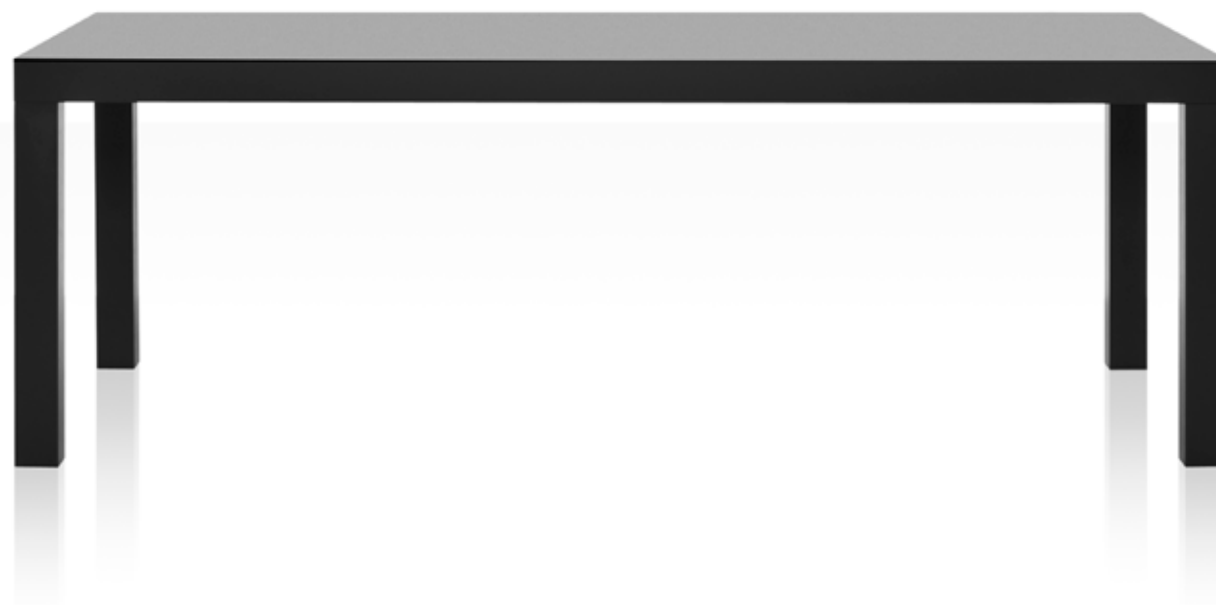
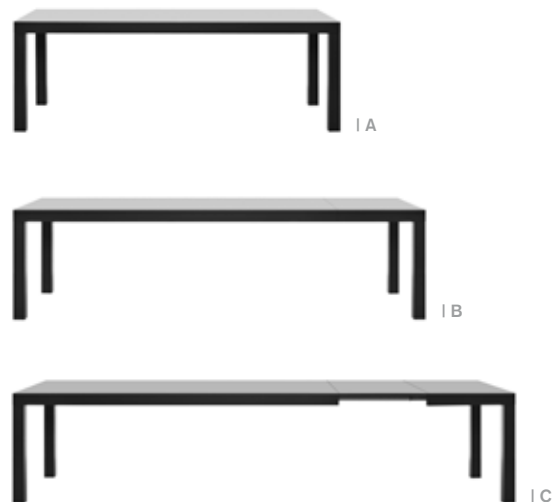

Il suo piano in vetro, laccato, o in
essenza offre uno spazio vasto e nobile.
Sobrio, come si addice ai nomi importanti.
Disponibili anche cromate, le caratteri-
stiche gambe a sezione triangolare liberano
nuova energia mentre puntano sottili verso
il mondo, illuminandolo.
Tavolo Magno. In grande stile.

Its surface in essence, varnished or glass
offers a wide and noble space. Its sobriety
fits with its important name. The original
triangular table legs are available also in
different colours, spreading their bright
energy while they point directly to the
world, to brighten it up.
Magno Table. Great style.





Pg.87 | Tavolo Magno con struttura in laccato lucido spazzolato Bianco e piano in vetro lucido verniciato Bianco: L 220 H 75 P 100. Sedia Emi imbottita e rivestita in pelle Pantea: L 49 H 85 P 61. Pouf Cubo imbottito e rivestito in pelle Pantea: L 45 H 45 P 45.

P.87| Magno table with structure in Bianco high gloss lacquered and top in Bianco high gloss glass: W 220 H 75 D 100. Emi chair, upholstered and covered in Pantea leather: W 49 H 85 D 61. Cubo upholstered pouf, covered in Pantea leather: W 45 H 45 D 45.

Pg.88-89 | Tavolo Magno con struttura in acciaio spazzolato e piano in vetro opaco verniciato Lavagna: L 190 H 75 P 90. Sedia Gamma con struttura a traliccio in metallo cromato e seduta imbottita e rivestita in tessuto sfoderabile: L 52 H 79 P 52.

P.88-89 | Magno table with brushed steel structure and Lavagna matt glass top: W 190 H 75 D 90. Gamma chair with chrome pylon structure and upholstered seat with removable cover: W 52 H 79 D 52.

Pg.90-91 | Vista frontale e laterale del tavolo Magno nella posizione chiusa(A) o allungata di L 60(B).

P.90-91 | Front and side view of Magno table in its closed position (A) or extended by 60 cm (B).





Le linee spezzate e i colori sgargianti impreziosiscono le differenze tra basamenti, stabili e leggeri. Morbida come pelle, lucente di vernice o fresca sul tessuto, regala la comodità a cui non serve altro. Semplice e ricercata nel design, si riconosce dal gusto essenzialmente dolce. Sedia Gamma. Oltre lo standard.

The broken lines and the vivid colours enrich the differences between the bases, which are light and steady. Soft as leather, fresh as textile and bright as varnish, it gives you comfort and all the rest is unnecessary. A simple and elegant design, that you can recognise from its sweet taste. Gamma Chair. Beyond the standard.



Pg.95 | Sedia Gamma con struttura a traliccio in metallo cromato e seduta imbottita e rivestita in tessuto sfoderabile: L 52 H 79 P 52.

P.95 | Gamma chair with chrome pylon structure and upholstered seat with removable cover: W 52 H 79 D 52.

Pg.96-97 | Vista frontale e laterale della sedia Gamma nella versione con struttura a traliccio(A), con quattro gambe in metallo(B) o con quattro razze in legno(C).

P.96-97 | Front and side view of Gamma chair in the version with pylon structure (A), with four metal legs (B) or with four wooden rocket legs (C).



Il disegno è irrevocabile ed equilibrato in ogni dettaglio, severo, ma giusto. Il legno solido della struttura è in laccato opaco, oppure in essenza. E per chi ama riposarsi su di un destino più morbido, la seduta può essere leggermente imbottita e rivestita. Sedia Karma. Destinata all'equilibrio.

The design is definitive and balanced in every detail, severe but right. The wood is solid and the structure can be in opaque varnish or in essence. If you prefer to rest on a softer destiny the chair can be slightly stuffed and covered. Karma Chair. Designed for balance.



Pg.99 | Sedia Karma con struttura in legno e seduta in laccato opaco Bianco e Lavagna o imbottita e rivestita in cuoietto: L 48 H 81 P 54.

Pg.100-101 | Vista frontale e laterale della sedia Karma nella versione con seduta in legno(A) o imbottita e rivestita in cuoietto(B).

P.99 | Karma chairs with wooden structure and seat in Bianco and Lavagna matt lacquered or upholstered and covered in hide: W 48 H 81 D 54.

P.100-101 | Front and side view of Karma chair in the version with wooden seat (A), or upholstered and covered in hide (B).



Soffice e versatile nel disegnare ogni ambiente che la ospita. Confortevole con chi ha il piacere di accogliere. Finemente imbottita e rivestita a scelta in pelle o tessuto, offre relax a 360 gradi in qualsiasi condizione. E fuori potrebbe anche essere inverno, piovere, o esserci un forte vento. Ma seduti qui, non conta più così tanto.
Sedia Emi. Rilassarsi è morbido.

Thanks to its flexibility and softness it draws every environment in which it's hosted. It welcomes with pleasure and comfort. Delicately stuffed, covered with leather or textile, it offers complete relax in every condition. It may be winter outside, it may rain or blow a strong wind, but if you sit here it doesn't matter anymore.
Emi Chair. Soft relax.



Pg.103 | Sedia Emi imbottita e rivestita in tessuto sfoderabile: L 49 H 85 P 61.

P.103 | Emi upholstered chair with removable fabric cover: W 49 H 85 D 61.

Pg.104-105 | Vista frontale e laterale della sedia Emi.

P.104-105 | Front and side view of Emi chair.



Leggera come l'aria, si modella sul corpo. E quando siedi sopra una nuvola, quel che vedi davanti a te è un panorama mozzafiato. Su tutto, le linee essenziali di un movimento fluido e i colori di una notte limpida nella quale l'infinito Nero del cielo e il lucente Bianco di stelle si incontrano.

Sedia Nuvola. Orizzonte libero.

Light as air it gets the shape of your body and when you sit on a cloud what you see is a breathtaking landscape. Above everything you will see the essential lines of a fluid movement and the colours of a clear night in which the endless dark sky and the bright white of the stars meet.

Nuvola Chair. Free horizon.



Pg.107 | Sedia Nuvola con struttura e seduta in laccato lucido Bianco e Nero: L 47 H 77 P 58.

P.107 | Nuvola chair with Bianco and Nero high gloss lacquered structure and seat: W 47 H 77 D 58.

Pg.108-109 | Vista frontale e laterale della sedia Nuvola.

P.108-109 | Front and side view of Nuvola chair.



KELLY12

Sempre attuale, classica nello stile. Rivestita in morbido cuoietto, con il suo taglio lungo a schienale alto esprime una femminilità dirompente ed elegante. La versione a schienale basso ne evidenzia invece la sensualità sottile, agile come una provocazione riuscita. Sedia Kelly12. Il nome della seduzione.

Always actual and classic in style. Its cover in hide and its high back express an elegant and shattering femininity. The version with the low back instead, underlines a subtle sensuality, agile as a well made provocation. Kelly12 Chair. The name of seduction.



Pg.111 | Sedia Kelly12 con schienale alto e basso, imbottita e rivestita in cuoietto Bianco e Nero: L 45 H 87/95 P 56.

Pg.112-113 | Vista frontale e laterale della sedia Kelly12 nella versione con schienale alto(A) e basso(B).

P.111 | Kelly12 chair with high and low back, upholstered and covered with Bianco and Nero hide: W 45 H 87/95 P 56.

P.112-113 | Front and side view of Kelly12 chair in high-backed (A) and low-backed (B) versions.



Semplicità e organicità delle forme affiancano un nome che regala sfumature esotiche a linee tradizionali, dal sapore vintage e familiare. Il legno è l'elemento preponderante, ma è anche possibile aggiungere sulla seduta una comoda imbottitura rivestita in pelle sintetica. Sedia Asia. Praticità senza frontiere.

Simple and concrete its features match to a name that gives exotic shades to traditional lines, with a vintage and familiar taste. Wood is the main element, but it is possible to add a comfortable stuffing covered in eco-leather to the chair.

Asia Chair. Pragmatism over frontiers.



Pg.115 | Sedie Asia con struttura in legno Rovere Grigio e Canaletto, seduta in legno in tinta o imbottita e rivestita in pelle sintetica: L 43 H 86 P 52.

Pg.116-117 | Vista frontale e laterale della sedia Asia nella versione con seduta in legno (A) o imbottita e rivestita in pelle sintetica (B).

P.115 | Asia chairs with wooden structure in Rovere Grigio and Canaletto, matching wooden seat or upholstered seat covered in eco-leather: W 43 H 86 D 52.

P.116-117 | Front and side view of Asia chair in the version with wooden seat (A), or upholstered and covered in eco-leather (B).





FINITURE FINISHES

Dall'ampio catalogo Pianca, il capitolo Finiture illustra la gamma di materiali, mostrando anche la ricca scelta cromatica disponibile.

From pianca's wide catalogue, the section finishing & colours shows the material range and the rich chromatic choice available.

ESSENZE WOOD

ROVERE NATURALE



ROVERE GRIGIO



ROVERE SCURO

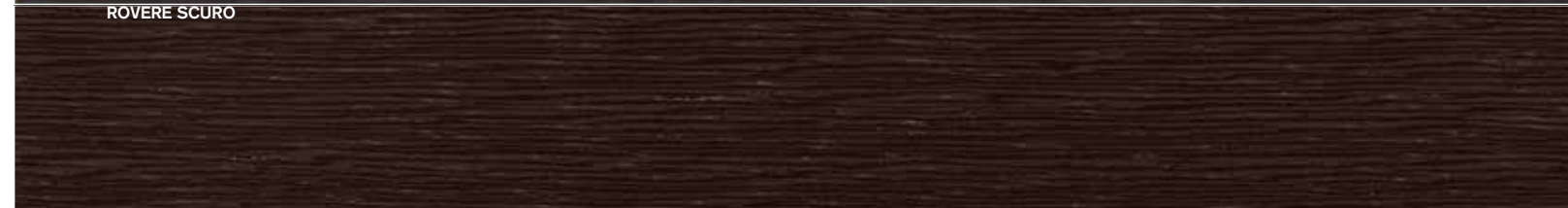

NOCE CANALETTO



PIETRE STONE

BLACK-LINE



MULTICOLOR



LACCATI OPACHI/LUCIDI SPAZZOLATI/PORO APERTO
MATT LACQUERED/HIGH GLOSS LACQUERED/OPEN PORE



VETRI OPACHI/LUCIDI
MATT GLASS/HIGH GLOSS GLASS

BIANCO

AVORIO

TORTORA

CRETA

LAVAGNA

NERO

SPECCHI
MIRROR

ARGENTO

FUME

STOP-SOL

INFO TECNICHE TECHNICAL INFO

La gamma dei prodotti, estremamente ampia ed in continua evoluzione, soddisfa ogni necessità d'arredo, nel segno della bellezza, della funzionalità, della durata e della trasversalità con gli altri ambienti della casa. Le dimensioni sono disponibili in cm. Le combinazioni disponibili tra L, H e P vanno verificate con i nostri rivenditori autorizzati.

Its vast range of continuously developing products meets all furnishing requirements, adding beauty, functionality, durability and versatility to all the rooms in the home. Dimensions are available in cm. The combinations available between W, H and D must be examined with our authorized retailers.



1 | QUADRA
L/W 100-120-150-180-200-240 | H 50-60-100-120-150-180
P/D 35-45-55
Pg. 8



2 | CONTEMPORANEA
BATTENTE: L/W 120 | H 141 | P/D 45
COMPLANARE: L/W 200-240 | H 60-90 | P/D 35-45-55
Pg. 14



3 | SPAZIO LINEARE
L DA 20 CM OGNI 10 CM / W FROM 20 CM EVERY 10 CM
H DA 20 CM OGNI 10 CM / H FROM 20 CM EVERY 10 CM
P/D 35-45-55
Pg. 20



4 | VISION
L/W 200-240 | H 40-60-90 | P/D 35-45
Pg. 30



5 | SPAZIO VOLUMI
L DA 20 CM OGNI 10 CM / W FROM 20 CM EVERY 10 CM
H DA 20 CM OGNI 10 CM / H FROM 20 CM EVERY 10 CM
P/D 35-45-55
Pg. 36



6 | SPAZIO GIORNO
L DA 20 CM OGNI 10 CM / W FROM 20 CM EVERY 10 CM
H DA 20 CM OGNI 10 CM / H FROM 20 CM EVERY 10 CM
P/D 35-45-55
Pg. 42



7 | PEOPLE
BATTENTE: L/W 27-52-65-131-196-261 | H 20-25-29-38-59-133-198
P/D 37-42-52
COMPLANARE: L/W 196-261 | H 73 | P/D 52
Pg. 48

1 | laccato opaco - lucido spazzolato **2** | laccato opaco - lucido spazzolato - poro aperto - Rovere Grigio - Canaletto **3|4|5|6** | struttura: laccato opaco - lucido spazzolato - poro aperto - Rovere Grigio - Canaletto; frontali: laccato opaco - lucido spazzolato - poro aperto - Rovere Grigio - Canaletto - vetro - specchio - pietra; pedane: laccato opaco - lucido spazzolato - poro aperto - Rovere Grigio - Rovere Naturale - Canaletto **7** | struttura: laccato opaco - lucido spazzolato - Rovere Scuro - Rovere Grigio - Canaletto; frontali: laccato opaco - lucido spazzolato - Rovere Scuro - Rovere Grigio - Canaletto - vetro - Stop-sol

1 | matt lacquered - high gloss lacquered **2** | matt lacquered - high gloss lacquered - poro aperto - Rovere Grigio - Canaletto **3|4|5|6** | structure: matt lacquered - high gloss lacquered - poro aperto - Rovere Grigio - Canaletto; frontal: matt lacquered - high gloss lacquered - poro aperto - Rovere Grigio - Canaletto - glass - mirror - stone; bases: matt lacquered - high gloss lacquered - poro aperto - Rovere Grigio - Rovere Naturale - Canaletto **7** | structure: matt lacquered - high gloss lacquered - Rovere Scuro - Rovere Grigio - Canaletto; frontal: matt lacquered - high gloss lacquered - Rovere Scuro - Rovere Grigio - Canaletto - glass - Stop-sol



8 | SOFFIO
L DA 90 A 240 CM OGNI 10 CM / W FROM 90 TO 240 CM
EVERY 10 CM | H 75 | P/D 80-90-100-120-140
Pg.56



9 | DELTA
L/W 160-190-220 | H 75 | P/D 90-100
Pg.68



10 | CARTAGENA
L/W 149-182-200-240 | H 75 | P/D 90-100
Pg. 74



11 | NEXT EVO
L/W 100-135-165-180-220 | H 75 | P/D 90-100
Pg. 80



12 | MAGNO
L/W 160-190-220 | H 75 | P/D 90-100
Pg. 86



13 | MINISOFFIO
L/W 120-140 | H 75 | P/D 45
Pg. 62



14 | ASIA
L/W 43 | H 86 | P/D 52
Pg. 114



15 | KELLY12
L/W 45 | H 87-95 | P/D 56
Pg. 110



16 | NUVOLA
L/W 47 | H 77 | P/D 58
Pg. 106



17 | GAMMA CON TRALICCIO
L/W 52 | H 79 | P/D 52
Pg. 94



18 | GAMMA CON RAZZE
L/W 52 | H 79 | P/D 52
Pg. 94



19 | GAMMA CON GAMBE
L/W 52 | H 79 | P/D 52
Pg. 94



20 | KARMA
L/W 48 | H 81 | P/D 54
Pg. 98



21 | EMI
L/W 49 | H 85 | P/D 61
Pg. 102

8 | struttura: metallo verniciato opaco; piano: laccato opaco antigraffio - vetro
acciaio spazzolato - Rovere Grigio - Rovere Naturale - Canaletto; piano: vetro
9 | gambe: laccato opaco - Rovere Grigio - Rovere Naturale - Canaletto; piano: vetro
10 | Rovere Scuro - Rovere Grigio - Canaletto
11 | laccato opaco antigraffio - poro aperto antigraffio - Rovere Grigio - Canaletto
12 | struttura: laccato opaco nei colori dei vetri - lucido spazzolato nei colori Bianco e Nero - Rovere Grigio - Rovere Scuro - Canaletto - acciaio spazzolato; piano: laccato opaco o lucido antigraffio nei colori Bianco o Nero - Rovere Grigio - Rovere Scuro - Canaletto - vetro
13 | struttura: metallo verniciato opaco; piano: laccato opaco antigraffio - vetro

8 | structure: matt painted steel; top: scratchproof matt lacquered - glass
brushed steel - Rovere Grigio - Rovere Naturale - Canaletto; top: glass
9 | legs: matt lacquered - Rovere Grigio - Rovere Naturale - Canaletto; top: glass
10 | Rovere Scuro - Rovere Grigio - Canaletto
11 | scratchproof matt lacquered - scratchproof poro aperto - Rovere Grigio - Canaletto
12 | structure: matt lacquered colors available for glass finishes - Bianco and Nero high gloss lacquered - Rovere Scuro - Rovere Grigio - Canaletto - brushed steel; top: Bianco or Nero matt lacquered or scratchproof high gloss lacquered - Rovere Scuro - Rovere Grigio - Canaletto - glass
13 | structure: matt painted steel; top: scratchproof matt lacquered - glass

14 | struttura: Rovere Scuro - Rovere Grigio - Canaletto; seduta: Rovere Scuro - Rovere Grigio - Canaletto - imbottita e rivestita in pelle sintetica nera
15 | imbottita e rivestita in rigenerato o cuoietto
16 | struttura: cromo - verniciato Bianco o Nero; seduta: laccato opaco colore - laccato lucido Bianco o Nero
17 | **18** | **19** | struttura: cromo - verniciato opaco Bianco - Rovere Grigio - Rovere Naturale - Canaletto; seduta: laccato opaco colore - laccato lucido Bianco - imbottita e rivestita in tessuto o pelle
20 | struttura: laccato opaco colore - Rovere Grigio - Canaletto; seduta: laccato opaco colore - Rovere Grigio - Canaletto - imbottita e rivestita in rigenerato o cuoietto
21 | imbottita e rivestita in tessuto o pelle

14 | structure: Rovere Scuro - Rovere Grigio - Canaletto; seat: Rovere Scuro - Rovere Grigio - Canaletto - upholstered in black eco-leather
15 | upholstered in hide or regenerated
16 | structure: chrome - Nero or Bianco lacquered; seat: color matt lacquered - Nero or Bianco high gloss lacquered
17 | **18** | **19** | structure: chrome - Bianco matt lacquered - Rovere Grigio - Rovere Naturale - Canaletto; seat: color matt lacquered - Bianco high gloss lacquered - upholstered in fabric or leather
20 | structure: color matt lacquered - Rovere Grigio - Canaletto; seat: color matt lacquered - Rovere Grigio - Canaletto - upholstered in hide or regenerated
21 | upholstered in fabric or leather

Photo:
Beppe Brancato
Concept image & Styling:
Alessandro Pasinelli
Styling Assistant:
Veronica Leali
Copywriter:
Francesco Cremonese
Lucia Viola Zampieri

Lithography & Printing:
Tipolitografica CS
Printed in Italy

Thanks to:
100 Fa
Crazy Art
Galleria Luisa delle Piane
Lo Spazio di Davide Lovatti
Mauro Bolognesi
Officina Antiquaria
Raw
Scenaperta
Sciortino
Spazio 900
Understate